

HISTORY OF ART
IN PHRYGIA LYDIA
CARIA AND LYCIA



5. 15. 12.

Library of the Theological Seminary
PRINCETON, N. J.

Division... DS 155

Section... P 46

HISTORY OF ART IN PHRYGIA,
LYDIA, CARIA, AND LYCIA.

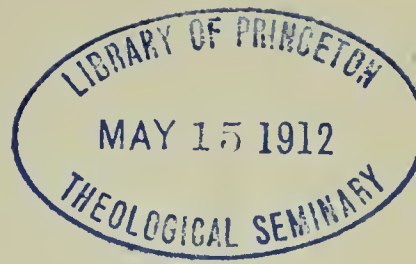

HISTORY OF
Art in Phrygia, Lydia, Caria,
AND
Lycia.

FROM THE FRENCH
OF
GEORGES PERROT,

MEMBER OF THE INSTITUTE ; PROFESSOR IN THE FACULTY OF LETTERS, PARIS,

AND

CHARLES CHIPIEZ.

ILLUSTRATED WITH TWO HUNDRED AND EIGHTY ENGRAVINGS.



London: CHAPMAN AND HALL, LIMITED.

New York: A. C. ARMSTRONG AND SON.

1892.

CONTENTS.



PHRYGIA, MYSIA, BITHYNIA, AND PAPHLAGONIA.

CHAPTER I.

	PAGE
THE PHRYGIAN NATION	I
§ 1. History and Origin of the Phrygians	1—23
§ 2. Customs and Religion of the Phrygians.	23—36

CHAPTER II.

PHRYGIAN ART	37
§ 1. Sipylus and its Monuments	37—70
§ 2. Architectural Characteristics of Phrygia Proper	70—78
§ 3. Funereal Architecture	78—142
§ 4. Religious Architecture	142—155
§ 5. Military Architecture	155—164
§ 6. Sculpture	164—178
§ 7. Ornament and Industrial Arts	179—192
§ 8. Tombs in Paphlagonia	192—211
§ 9. General Characteristics of Phrygian Civilization and its Influence upon Hellenic Culture	211—231

LYDIA AND CARIA.

CHAPTER I.

THE LYDIANS, THEIR COUNTRY, HISTORY, AND RELIGION	232—257
---	---------

CHAPTER II.

ART IN LYDIA	258
§ 1. Architecture	258—280
§ 2. Sculpture and Numismatics	280—285
§ 3. Industrial Arts	285—298
§ 4. General Characteristics of Lydian Civilization	298—301

CHAPTER III.		PAGE
CARIA		302
§ 1. History of the Carians		302—309
§ 2. Funereal Architecture		309—313
§ 3. Religious and Military Architecture		314—319
§ 4. Industrial Arts		319—327
§ 5. General Characteristics of Carian Civilization		327—330

LYCIA

CHAPTER I.

THE LYCIANS, THEIR COUNTRY, HISTORY, AND RELIGION	331
§ 1. The Country	331—337
§ 2. History	337—353

CHAPTER II.

ARCHITECTURE	354
§ 1. Funerary Architecture	354—377
§ 2. Towns and their Defences	377—381

CHAPTER III.

SCULPTURE	382—391
---------------------	---------

CHAPTER IV.

GENERAL CHARACTERISTICS OF LYCIAN CIVILIZATION	392, 393
INDEX	401—405

LIST OF ILLUSTRATIONS.

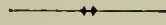

FIG.	PAGE
1. Inscription on the so-called Tomb of Midas	8
2. Phrygian alphabet	8
3. Phrygian inscription	31
4. Archi-Gallus	33
5. Cybele enthroned. Coin	35
6. Cybele seated on lion. Coin	35
7. Map of Sipylus	38
8. View of the Iamanlar Dagħ from the quay of Smyrna	39
9. Topographical sketch north-west of the plain of Bournabat	40
10. Post of observation on Sipylus	41
11. Acropolis, Iamanlar Dagħ	43
12. Northern wall of Acropolis	44
13. Gateway to Acropolis	45
14. View of tomb of Tantalus	46
15. Plan of tomb of Tantalus	47
16. Chamber of tomb of Tantalus. Longitudinal section	47
17. Chamber of tomb of Tantalus. Transverse section	47
18, 19. Terminal phalli	49
20, 21. Tumuli built of uncemented stones	50
22. Plan of sanctuary, Iamanlar Dagħ	51
23. Sanctuary. Section through A B	52
24. Sanctuary. Plan of chamber	52
25. Sanctuary. Wall of chamber	53
26. Sanctuary. Section through F H	53
27. Sanctuary. Wall of enclosure on the north-west	53
28. Topographical sketch of northern slope of Sipylus, east of Magnesia	57
29. Iarik Kaia. Topographical sketch	58
30. Plan of houses	59
31. Rock-cut dwellings. Perspective view	60
32. Niche hollowed in the rock. Perspective view	60
33. Niche hollowed in the rock. Longitudinal section	61
34. Tomb excavated in the rock, near Magnesia. Perspective view	62
35. Tomb near Magnesia. Plan	62
36. Tomb near Magnesia. Longitudinal section	63

FIG.	PAGE
37. Tomb near Magnesia. Transverse section	64
38. Tomb near Magnesia. Horizontal projection of upper part	64
39. Tomb near Phocæa. Perspective view	65
40. Tomb near Phocæa. Plan	66
41. Tomb near Phocæa. Longitudinal section	66
42. Bust carved in the rock	68
43, 44. Wooden houses near Kumbet	71
45. View of Kumbet	72
46. Plan of house hollowed in the rock, Kumbet	75
47. Phrygian necropoles. Topographical sketch	77
48. The Midas monument	81
49. False door to the Midas monument	84
50. Delikli Tach. Perspective view	87
51. Delikli Tach. Detail of doorway	89
52. Delikli Tach. Perspective section through transverse axis	91
53. Delikli Tach. Plan of vault	93
54. Delikli Tach. Profile of lintel on inner jamb	93
55. Delikli Tach. Profile of lintel on exterior jamb	93
56. Delikli Tach. Tinted scroll on soffit	94
57. Delikli Tach. Engraved characters on jamb of doorway	94
58. Rock-cut façade	95
59. Rock-cut façade	99
60. Tomb in the Ayazeen necropolis	102
61. Rock-cut façade. Perspective view	103
62. Plan of tomb at Bakshish	105
63. Tomb showing mouth of well	105
64. Tomb in the Ayazeen necropolis	107
65. The Broken Tomb. Present state	111
66. The Broken Tomb. Restored plan	110
67. The Broken Tomb. Restored transverse section through north face	113
68. The Broken Tomb. Transverse section through back of vault	113
69. The Broken Tomb. Restored longitudinal section through west face	114
70. The Broken Tomb. Restored longitudinal section through east face	114
71. The Broken Tomb. Restored view of interior of vault	115
72-74. Tomb near Pishmish Kaleh. Plan, façade, and section	118
75. Tomb at Yapuldak. Elevation of the façade and section through the axis of the same	120
76. A hieroglyphic character	120
77. Tomb near Ayazeen. Façade	122
78-81. Plan and three transverse sections of the tomb	123, 124
82. Tomb at Ayazeen	127
83. The Kumbet tomb. General view	125
84. The Kumbet tomb. Façade	128
85, 86. The Kumbet tomb. Plan and longitudinal section	129
87. The Kumbet tomb. Heads carved on cornice	130
88. The Kumbet tomb. Palmette at angle of cornice	130
89. The Kumbet tomb. Inscription	131

FIG.	PAGE
90. Tomb at Yapuldak	132
91. Gherdek Kaiasi. Restored façade	134
92. Tomb at Ayazeen	136
93-96. Ionic capital. Present state, perspective view. Plan. Lateral elevation. Elevation	137
97. Calathiform capital and profile of shaft and entablature	137
98. Elevation and profile of pilaster in Broken Tomb	138
99. Plans of pilaster, above the base and commencement of capital	138
100. Valley of Doghanlou and Midas city. Topographical sketch.	142
101. Rock-cut altar and bas-relief	143
102. Rock-cut altar	144
103, 104. Rock-cut altars	145
105. Rock-cut altar. Section through axis	146
106. Rock-cut altar	146
107. Figure of Cybele	147
108. Arslan Kaia. General view	149
109. Arslan Kaia. Western face	152
110. Arslan Kaia. Bas-relief on end wall of chamber	153
111. Figure of Cybele carved in niche	154
112. Pishmish Kaleh. View of hill	156
113. Pishmish Kaleh. Plan	157
114. Pishmish Kaleh. Inner view of rock-cut rampart	159
115, 116. The two sides of a stone ram	165
117. Bas-relief of Broken Tomb	169
118. Bas-relief of Broken Tomb	168
119. Helmet, from early Greek vase with black figures	172
120. Lion of Broken Tomb	174
121. Broken Tomb. Restoration of rampant lion	177
122. Broken Tomb. Restoration of two lions facing each other	177
123. Tomb near Iasili Kaia. Elevation	180
124, 125. Tomb near Iasili Kaia. Plan and transverse section	181
126. Tomb near Iasili Kaia. Perspective view of main chamber	183
127. Tomb of the Ayazeen necropolis. Door-frame	186
128. Scroll on sepulchral façade	187
129. Turkish woman at her loom	189
130. Comb of carpet-maker	190
131. Tomb at Kastamouni. General plan	195
132, 133. Kastamouni. Tomb 1. Frontal. Ceiling of chamber	196
134, 135. Kastamouni. Tombs 2 and 4. Transverse sections	196
136. Hambar Kaia. General view	197
137. Hambar Kaia. Plan of tomb	199
138. Hambar Kaia. Column	199
139. Hambar Kaia. Façade of tomb	200
140. Iskelib. General view	201
141. Iskelib. Tomb I. Plan	203
142. Iskelib. Tomb I. Elevation of porch	203
143. Iskelib. Tomb I. Transverse section through back of chamber	204

FIG.	PAGE
144. Iskelib. Tomb III. Plan	204
145, 146. Iskelib. Tomb III. Transverse and longitudinal section	205
147. Iskelib. Tomb III. Imitation of a wooden loft	205
148. Iskelib. Tomb III. Transverse section through back of chamber	205
149. Iskelib. Tomb IV. View of façade	206
150, 151. Iskelib. Tomb IV. Plan and transverse section	207
152. Iskelib. Tomb I. Section under porch	209
153. Site and ruins of Sardes. Topographical sketch	242
154. View of Acropolis, Sardes	244
155. Scene in Egyptian market-place	251
156. Weighing of gold ingots, Egypt	252
157. Necropolis and environs of Sardes. Map	259
158. View of tomb of Alyattes	261
159. Plan of tomb of Alyattes	262
160. Perspective view of interior of tomb	263
161. Inner view of doorway	264
162. Passage	265
163. Section of tumulus	266
164. Section of restored tumulus	266
165. Terminal stone	266
166-169. Lydian tomb. Plan, sealing slab, two sections	268, 269
170-173. Lydian tomb. Plan, two sections, sealing slab	269, 270
174-176. Lydian tomb. Plan, section, aspect of facing	270, 271
177. Tumulus. Plan and section	271
178. Funereal bed	272
179. Funereal bed, with painted ornaments	273
180. Tumulus at Belevi. Notch cut in the rock	274
181, 182. General view and plan of tumulus	274, 275
183, 184. Longitudinal section. Plan of chambers	275, 276
185. Perspective view of second chamber	276
186, 187. Third chamber. Two sections	277
188, 189. Two Lydian coins	282, 283
190, 191. Two Lydian coins	283
192. Lydian coin	284
193. Alabastron	285
194, 195. Vases from the tomb of Alyattes	286
196-199. Fragments of vases from the tomb of Alyattes	286
200-202. Fragments of vases from Bin Tepe	287
203. Lydian plaque	288
204. Back view of Lydian trinkets	289
205, 206. Lydian personal ornaments	290
207, 208. Lydian gold ornaments	291
209. Mould of serpentine	293
210. Mould of serpentine	295
211. Phrygian funereal couch	297
212. Carian inscription	304
213. Tomb near Iasus	310

FIG.	PAGE
214, 215. Tumulus at Assarlik. Plan and section	310, 311
216, 217. Tumulus at Gheresi. Plan and section	311, 312
218. Tumulus and surrounding wall	312
219. Funereal enceinte, Caria	313
220. Leleges' Wall. Plan	315
221. Gateway in Lelegian wall	316
222. Lelegian wall. Plan of tower and rampart	317
223. Lelegian wall. View of tower	317
224. Portion of plan of Alinda	318
225. Wall near Myndus	318
226-230. Carian pottery	320
231, 232. Vases from Idrias	321
233. Vases from Idrias, showing ornament	323
234. Carian pottery	322
235, 236. Fragments of pithos	325
237. Slab from sarcophagus	325
238-241. Slabs from sarcophagus	326
242. Bronze fibula	327
243. Stone statuettes	329
244. Map of the Xanthus Valley	333
245. Map of the plateau of Elmalu	334
246. Lycian alphabet	342
247. View of the Xanthus valley	345
248. View of Tlos	347
249. Lycian house, made of unsquared timber	356
250. Tomb at Keuibashi	357
251. Tomb at Hoiran	358
252. Views of cities, Pinara	361
253. Views of cities, Pinara	362
254. House at Ghendova	363
255. House at Ghieuben	363
256, 257. Lycian stores	364
258. Hut at Kurje Keui	365
259. Store at the Villards de Thônes (Savoy)	365
260. Tomb at Hoiran	366
261. Tomb at Pinara	367
262. Tomb at Phellus	368
263. Plan of tomb at Pinara	369
264. Tomb at Myra	370
265. Tomb at Pinara	371
266. Tomb at Antiphellus	372
267. Sarcophagus at Antiphellus	373
268. Funerary tomb at Xanthus	375
269. View of Lycian town	378
270. View of Lycian tomb	378
271. Plan of fortress, Pidnai	379
272. Wall at Pidnai	380

FIG.	PAGE
273-275. Bas-reliefs on tomb, Trysa	383
276. Tomb at Xanthus. Small side	384
277. Tomb at Xanthus. Corner view	385
278. Tomb at Xanthus. Long side	386
279. Tomb at Xanthus. Long side	387
280. Tomb at Xanthus. Small side	388

TAIL-PIECES.

Reverse of coin, Pessinus	36
Bust of Midas on coin, Prymnessus	231
Monetiform ingot, Ægina, in the Cabinet de France	257
Electrum stater, attributed to a king of Lydia	301
Reverse of coin. Zeus Stratios, Mylasa	330
Lycian coin, with wild boar type	353
Lycian coin. Triskelis type (three-headed)	381
Lycian coin	391
Lycian coin	393

HISTORY OF ART IN ANTIQUITY.

PHRYGIA, MYSIA, BITHYNIA, AND PAPHLAGONIA.

CHAPTER I.

THE PHRYGIAN NATION.

HISTORY AND ORIGIN OF THE PHRYGIANS.

THE part the Phrygians played in the Oriental world is not so important as that played by the Hittites, but the modern historian knows next to nothing of the latter, whilst he is acquainted with the house, parentage, and family of speech of the former. The Phrygians appeared later on the scene of history; they lived in closer proximity with the Greeks, and left inscriptions, few and brief it is true, but written with characters the full values of which are determined. Herodotus and Xanthus of Lydia, who wrote about the fifth century B.C., are agreed in placing the cradle-land of the Phrygians, Mysians, and Bithynians in Thrace, whence they penetrated into Asia Minor across the straits.¹ Their testimony

¹ Herodotus, vii. 73; Xanthus, p. 5; *Fragm. Hist. Græc.*, C. MÜLLER'S edit., tom. i. p. 37. Strabo (X. iii. 16) sums up the opinion of his predecessors, backed by the rich store of historical information which lay open to him, in the following words: "The Phrygians are a Thracian colony." So PLINY: "Sunt auctores transisse ex Europa Mysos et Brigas et Thynos, a quibus appellantur Mysi, Phryges, Bithyni" (*Hist. Natur.*, v. 41).

On the Thracian origin of the Bithynians, see also Thucydides, iv. 75; XENOPHON, *Anabasis*, VI. ii. 18; iv. 1, 2; *Hell.*, I. iii. 2; III. ii. 2; Herodotus, vii. 75, etc. The geographer clearly perceived that if Homer spoke of the Mysians and Thracians in the same line (*Iliad*, xiii. 3), this was meant to apply to those that had remained in Europe. The mistake of Herodotus (vii. 74), who writes of the Mysians and Lydians as one people, is easily accounted for from the fact that they fought under the same colours in the Persian army, and that long cohabitation on

was not wholly dependent upon the traditions the immigration might have left among the tribes established in the valleys of the Hermus and along the upper course of the Mæander; it rested also upon the fact that, many centuries after the separation, names of clans and localities were found east and west of the Hellespont, with scarcely any difference between them, beyond light shades of pronunciation. Nor is this all; the new country was sometimes called Asiatic Thracia, to distinguish it from Thracia proper. The like comparison was not possible between Phrygians and Armenians, albeit a close relationship was affirmed to exist between them. Herodotus, writing of the various nations which composed the army of Xerxes, says, "The Armenians are 'a Phrygian colony,'¹ equipped like the Phrygians, and when under arms obey a common chief." The little we know of their language would not belie the comparison thus instituted.² The terms, however, used by the historian imply an hypothesis unacceptable to our better informed judgment, since it is difficult to admit that the populations of Armenia were composed of tribes that had come from the west.³

the western coast of Asia had induced great similarity in their dialects and usages. Differences, no doubt, existed between them, but, though distinctly made out by natives, were not detected by strangers. Any one interested in the subject will find more texts in support of the Thracian origin of the people under discussion in F. LENORMANT, *Orig. de l'hist.*, tom. ii. pp. 366-371, and D'ARBOIS DE JUBAINVILLE, *Les Premiers habitants de l'Europe*, p. 168 and following.

¹ Φρυγῶν ἀποικοί, Herodotus, vii. 73. Cf. EUDOXUS, *Stephanus Byzantinus*, s.v. Ἀρμενιοί, and EUSTACE'S *Commentary*, 694. They went so far as to regard the appellatives Armenians and Phrygians as synonymous terms (CRAMER, *Anecdota Græca Oxoniensia*, iv. p. 257). JOSEPHUS (*Ant. Jud.*, i. 6) identifies the Phrygians with the descendants of the Togarmah of chapter x. of Genesis. Togarmah is generally taken to denote the Armenians.

² The relationship between the Phrygian and the Greek tongue was noticed by the ancients (PLATO, *Cratylus*, p. 410 A). Consult also LASSEN, *Zeitschrift der Deutschen*, etc., tom. x. p. 369 and following.

³ FR. LENORMANT, *Les Origines de l'histoire*, tom. ii. pp. 373-379. Consideration of the earliest Armenian traditions has led him to the conclusion that the Armenians entered the country we now call Armenia from the west, and that when the Assyrians reached it for the first time, the people in possession were not Armenians, but Urartai, Urartū, Alarodians. On this hypothesis the Thracian emigrants who pushed furthest east would be Armenians. DUNCKER (*Geschichte der Alterthums*, tom. i. p. 383), whilst admitting the kinship between Phrygians and Armenians, holds the opposite view. He refuses to accept the testimony of numerous ancient texts, in which the migration of the Phrygians from Europe to Asia is stated, and holds it worthless. In his estimation it was just the reverse. If the same names are met with in Phrygia and Thracia, this, he holds, was because the parent tribes of both Phrygians and Thracians, coming from the east, left in Armenia a first colony; a

If affinity exists between Armenians and Phrygians, it may, perhaps, be otherwise explained. The two nations would have come of a parent stock, a main branch of the Aryan family—a branch which parted in far-off days, and formed two distinct ramifications. Of these, the one moved north of the Euxine and settled in the south-east of Europe, whence long afterwards they fell back upon Asia Minor; whilst the other entered the peninsula at the opposite end, through the passes of Caucasus, and the high levels binding it with the tableland of Iran. After centuries of separation, the two groups met again on the river Halys, which rises in Armenia, and whose lower course forms the line of delimitation between Cappadocia and Phrygia.

Further to discuss the question is outside our purpose. Neither the Thracians nor the Armenians ever had an individual art, so that in no part of this history will their name be recorded. If we have adduced traditions bearing upon the origin and ethnical affinities of the Phrygians, this was because they determine the question of race, and serve to establish their Aryan origin, further demonstrated by words of their language incised on stone hard by Seid al-Ghazi.¹ Their idiom might almost be considered a Greek

second group, Phrygians, Mysians, Bithynians, established themselves on the north-west of Asia Minor; then moving still further west, the bulk of the nation crossed the straits, and spread in the vast region that lies between the Ægean and the Danube. This is a theory opposed to almost all ancient texts, the universal belief of antiquity, and Duncker borrowed it from Otto Abel, who has not one good reason to show for it ("Phryges," *Real Encyclopédie de Pauly et Makedonien*, p. 57). The few authorities he cites date from the Lower Empire, e.g. centuries after the events they purpose to relate.

¹ None of the scholars who have gone into the question have any doubt on the subject. See first Lassen's dissertation, already referred to (p. 2, note 2), entitled *Ueber die Lykischen Inschriften und die alten Sprachen Klein-Asiens*. In the second part (*Ueber die alten Kleinasiatischen Sprachen uerhaupt*) a large share is given to the study of the Phrygian language. The author, whilst giving the expositions of Jablonski, Adelung, Heeren, and De Lagarde, adds many observations of his own. The reader is referred to De Lagarde for a fuller account: *Einige Bemerkungen ueber êrânische Sprachen ausserhalb Erân's* (Gesamm. Abhand., 8vo, 1866, Leipzig). Chap. iii. pp. 283-291, deals with the glossary of Phrygian words preserved to us in ancient writers; but unlike Lassen, he makes no attempt to explain the inscriptions. Among the many correspondences these papers contain we will single out the following:—Hesychius (s.v.) formally states that *Βαγαίος* was the Phrygian name of Zeus. Despite its Greek ending, due to lexicographers, it is not difficult to recognize the *bagha*, which in old Persian, and Zered as well, signifies deity. The word, with scarcely any modification, occurs in many other Indo-European languages. *Bog*, in Slavic idioms, has the meaning of deity.

dialect; "the Phrygians," it has been said, "are eastern Greeks," a term of comparison fully justified by the close relations which existed between the Thracians and the ancestors of the Hellenes in continental Greece. The witness borne by all antiquity was to the effect that the Greeks were indebted to Thracian tribes established in the valleys of Olympus and Pindus for the religious rites of Dionysus and the Muses. Orpheus was a Thracian bard.

We have still to consider the question of date. When did the migration take place which brought these Thracian tribes, so nearly allied to the Greeks, to the very heart of Asia Minor? To fix the year, or even the century, when the first of these clans crossed the straits is not once to be thought of. Thus stated, the problem would be insoluble; on the other hand, a highly probable solution may be reached by confining ourselves to determining the position that ought to be assigned to the Phrygians among the many peoples that succeeded each other in Asia Minor—at any rate, those who, thanks to the superiority of their culture, swayed their neighbours and played a leading part, each in turn. Of all the nations who figured on this scene, first in chronological order are the Hittites. The literary documents of Egypt exhibit them, in the days of Thothmes, Seti, and Ramses, as not only supreme masters of Northern Syria, but as wielding enough of authority over the peninsula to have induced innumerable hosts to cross the Taurus in order to fight for the kings of Carchemish and Kadesh against the Pharaohs in the valley of Orontes, and later, in the reign of Menephtah and Ramses III., to have threatened the Egyptian frontiers as well. Is it not likely that, had the Phrygians then inhabited the peninsula, they must, willingly or unwillingly, have been drawn into the general ferment impelling the native populations across the mountains on to Syria? Now, in the long list of nations banded together under the leadership of the Khetas, including the tribes called somewhat later, by the Theban scribes, "seafaring people," we look in vain for the name of the Phrygians. If contemporary texts containing the recital of these stirring events make no mention of the Phrygian group, was it not simply because the populations composing it had not yet abandoned their Thracian and Mysian cradle-land, nor crossed the straits, but still dwelt in Europe, where the bulk of the nation preserved their individual life and independence down to the Roman conquest? This hypothesis, the cumulative know-

ledge of Greece, the gleanings—for him who knows how to gather them—to be got out of the monuments in which the handiwork of the Phrygians has been recognized, everything in fact, tends to confirm. The caravan routes of the western coast, which led to Smyrna, Ephesus, and Miletus, served as connecting links from the earliest days, between the Ionians and the main group of the Phrygian nation—that which has left its name to the portion of the plateau comprised between the middle course of the Halys, the head springs of the Sangarius and the Mæander. We may assume that the traditions relating to Ionia reflected, though faintly, the memories the Phrygians themselves had preserved of their own past; now, these traditions show no proneness for carrying very far back the migration which brought the Phrygian tribes to the peninsula, since Xanthus of Lydia definitely places the event after the Trojan war.¹ As Strabo has already remarked, such an assertion is difficult to reconcile with the testimony of the Homeric poem, in which the Phrygians are represented as the neighbours and allies of the Trojans (XII. viii. 4, XIV. v. 29). The Greeks had no desire to be found to disagree with Homer; just as, for a long time, whoever handled ancient history was at pains to make his theories fit in with the Bible. Hence it was admitted that the Greeks who followed Agamemnon to Asia, found the Phrygians already at home there and in possession of a vast territory; nevertheless the migration of the Thraco-Bryges, even for

¹ Xanthus, p. 5. Herodotus does not give the date of the migration which brought the Thracians to the peninsula; if he asserts that the Phrygians had every right to consider themselves as the oldest people in the world, it was on the strength of the experiment made by Psammeticus, which he fully details (ii. 2), but which has no historical value. Its only point of interest resides in the fact that it testifies to that first awaking of a questioning intelligence, which in time was to expand into comparative philology and in our age to take rank among sciences. The two infants reared by Psammeticus in a secluded cottage, wherein no human voice was ever heard, in their first cry imitated the bleating of a goat, said to resemble “bec, bec,” and one of the Asiatic Greeks in the king’s body-guard forthwith identified the sound with the Phrygian word *becos*, bread. The anecdote simply proves the readiness of the Greek mind to find a solution, good or bad, to any problem presented to it. For the rest, the Phrygians might be “very ancient” in Herodotus’ sense, and yet comparatively of recent date in Asia Minor. Arrian, in a passage preserved by Eustathes (*Denys Periegetes*, 322), says that the Phrygians passed from Thracia to Asia to escape the hardships consequent on the incursions of the Cimmerians. Inadmissible though this may be from a chronological standpoint, it is none the less important to show that authoritative writers were not disposed to carry back the migration under notice to remote antiquity.

writers who start from the above data, was not considered as an event which belongs to fabulous ages, and is lost in the twilight of time. Strabo, as we have seen, confines himself to saying that the tribes in question entered the peninsula before the Trojan war. At no time were the Phrygians, Mysians, and Bithynians, regarded by the ancients as the primitive inhabitants of Asia Minor, *autochthones*, to use the Greek expression.¹

Strictly speaking, the witness borne by instances such as these might be questioned, but what enhances their weight is the fact that they coincide with the views suggested to the historian by monuments discovered within this century by Leake, Stewart, T  xier, and Ramsay, on this very soil of Phrygia.² Crowded in a narrow space, these memorials belong one and all to the region

¹ The saying *T   Nann  kov*, in the time of Nannakos, has been advanced in proof of the contrary hypothesis, as shadowing very far-off days; for old King Nannakos was represented as the Noah of Phrygia, and as having rescued his subjects from the Deluge. The coins of Apam  a Kibotos are witnesses to the popularity of similar legends in a portion of the peninsula during Roman domination; but earlier writers make no allusion whatever to the deluge in question. The oldest text in which it is mentioned is ascribed to Hermogenes, who wrote in the first, perhaps in the second century of our era (M  LLER, *Frag. Hist. Gr  c.*, iii. p. 524). The dictum, "to weep over the days of Nannakos," is indeed found in a Iambic poet, one Herodas, Heroudas (BERGK, *Poet   lyrici Gr  ci*, tom. ii. p. 796); but no one knows where he lived, nor is there aught to indicate the meaning he attached to the words *T   Nann  kov*. When Strabo (XII. viii. 13) tells us that *kibotos*, casket, coffer, was affixed to Apam  a of Phrygia, he does not in any way connect the surname with a deluge. It may be questioned whether the tradition of the Phrygian flood is in truth very old, and was not an importation of the Jews, who in very early days would have entered the country through Cilicia, and spread in the townships of the central plateau. The Acts of the Apostles show that Hebrew communities were established in Lycaonia in the opening years of our era. N  LDEKE (*Untersuchungen zur Kritik des alten Testaments*, 8vo, 1886, pp. 154, 155) and FR. LENORMANT (*Les Origines*, 2nd edit., tom. i. pp. 440, 441) admit that traditions of a local deluge, akin to those which in Greece were connected with Deucalion, may have been current in Phrygia, but they acknowledge at the same time that such myths could not acquire any importance before the second century A.D., and were brought about by infiltration of Jewish and Christian ideas. This is proved in the name of ΝΩΕ, ΝΩ, engraved on native coins and clearly foreign to Phrygian myths.

² W. MARTIN LEAKE, *Journal of a Tour in Asia Minor*, 8vo, London, 1824. His journey was undertaken in 1800, in which year he visited the monument which bears the name of Midas written upon it. He was the first European who saw and made a drawing of the fa  ade. An abridged account of his travels appeared in Walpole's *Memoirs*, under the title "Travels in Various Countries of the East."

JOHN ROBERT STEWART, *A Description of Some Ancient Monuments with Inscriptions*, etc., London, 1842. The letter-press is indifferent, and the plates, taken

where, by common consent, is placed the cradle of the Phrygian race—the scene, at least, upon which the nation unfolded and laid the foundation of a mighty kingdom. Here were many temples, and many votive objects put therein; the famous chariot, for example, upon which Alexander the Great rested his hand for a while,¹ and many sacred springs;² whilst the names of Gordios and Midas linger to this day in Gordion and Midaion, where once these kings were enthroned, but which are now reduced to mere hamlets.³ These names, about which cluster so many fables, are prominent figures in the Phrygian mythic cycle; one might be inclined to regard them as purely legendary, but for the fact that they appear on the sculptured façades of the Phrygian sepulchres, written in letters not a whit more difficult to read than very old

from incorrect sketches, are far from satisfactory. The book is valuable on account of the inscriptions, copied, as a rule, with care.

TÉXIER, *Description de l'Asie Mineure*, tom. i. pp. 153–162, Plates VI.–LXI. The drawings are among the best brought home by Téxier; a few of them only require light corrections to make them quite exact.

G. PERROT, Ed. Guillaume et J. Delbet, *Explor. Arché. de la Galatie*, tom. i. pp. 135–186, 168–170, Plates VII., VIII. The little time the explorers had at their disposal obliged them to confine their observations to the so-called Tomb of Midas and the fortress known as Pishmish Kalessi, but they made very complete and careful tracings.

W. M. RAMSAY, *Studies in Asia Minor*—I. *The Rock Necropolises of Phrygia; 2. Sipylos and Cybele*, Plates XVII.–XXII. (*Journal of Hell. Studies*, tom. iii. pp. 1–68); *Some Phrygian Monuments*, Plates XXVI.–XXIX., pp. 156–262; *Sepulchral Customs in Ancient Phrygia*, Plate XLIV. (*Journal*, tom. v. pp. 241–262). No one knows more about this district, its history and antiquities, than Professor Ramsay. He has visited it no less than six times from 1881 to the present year; twice in 1881, and once in 1884, 1886, 1888, 1890. Unfortunately he cannot hold a pencil, and the sketches of M. Blunt, his companion in one of these expeditions, leave much to be desired, and, according to Professor Ramsay, are not always reliable. It is to be regretted that Professor Ramsay should not collect and publish in a separate volume the mass of useful matter he has gleaned.

¹ ARRIAN, *Anabasis*, ii. 3; PLUTARCH, *Alexander*, xviii.

² Midas *springs* were pointed out to the traveller in several cities of the Phrygian plateau; one was at Ancyra (Pausanias, I. iv. 5), a town whose foundation was ascribed to Midas, and another in the neighbourhood of Tymbrion and Tyræon (XENOPHON, *Anab.*, I. ii. 13).

³ Strabo, XII. v. 3: Πλησίον δὲ καὶ ὁ Σαγγάριος ποταμὸς ποιεῖται τὴν ῥύσιν· ἐπὶ δὲ τούτῳ τὰ παλαιὰ τῶν Φρυγῶν οἰκητήρια Μίδου, καὶ ἔτι πρότερον Γορδίου καὶ ἄλλων τινῶν, οὐδ' ἔχνη σώζοντα πόλεων, ἀλλὰ κῶμαι, μικρῶ μείζους τῶν ἄλλων, οἷον ἐστὶ τὸ Γόρδιον καὶ Γορβειοῦς, τὸ τοῦ Κάστορος βασιλείου τοῦ Σαωκονδαρίου. On the probable position of Gordion, see PERROT, *Expl. Arché.*, tom. i. pp. 152–155. Midaion seems to have stood somewhat more to the south, on the old route which ran from Dorylæum, now Aski Sheher, to Pessinus.

ATEC: A P K I A E F A I S: A K E M A M O T A F O S: P / Δ A I: F A F A T A # F A F A K T E / # Δ A F E

FIG. 1.—Inscription of the monument called "Tomb of Midas." RAMSAY, *On the Early Historical Relations*, Plate I., Fig. 1.

Greek inscriptions (Fig. 1).¹ Not only do we no longer find any trace of those Hittite hieroglyphs which still await decipherment, but the alphabet that may be restored from them (Fig. 2) is not derived, as was probably that of Cyprus, from an old system of writing, which seemingly obtained throughout Asia Minor before the introduction of Phœnician characters. What is more, it does not contain, as the Lycian, Pamphylian, and Carian syllabaries, letters of Punic origin, along with others borrowed from that Asianic alphabet which is found in outline in the literary documents of Cyprus. There is not one letter here which we may not expect to find in Greek inscriptions. The Phrygian alphabet was not derived directly from the Phœnician; for it does not contain all its letters, whilst it has a few not possessed by the latter; it was in all likelihood allied to it through one or other of the archaic Greek alphabets, either the Ionian, or rather that called

a	Α Α
b	Β Β
g	Γ
d	Δ Δ
e	Ε Ε Ε
v	Ϝ Ϝ
z	Ϛ Ϛ Ϛ
ι	Ι
k	Κ Κ
l	Λ
m	Μ Μ Μ
n	Ν
o	Ο Ο
p	Ρ Ρ
r	Ϙ Ϙ
s	ϙ ϙ ϙ
t	Τ Τ
u	Υ
ph	ϕ

FIG. 2.—Phrygian alphabet. FR. LENORMANT, under the heading "Alphabet," in Daremberg and Saglio's Dictionary.

¹ Excellent copies of most Phrygian inscriptions will be found in the three plates subjoined to Professor Ramsay's interesting memoir, bearing the title, "On the Early Historical Relations between Phrygia and Cappadocia" (*Journal of the Asiatic Society of Great Britain and Ireland*, vol. xv. part i.). The third section of the memoir, "Archaic-Phrygian Inscriptions," is devoted to the Phrygian alphabet and its origin, together with a tentative decipherment and translation.

the "island syllabary."¹ The few short inscriptions of Thera (Santorin) are considered as the oldest in the Greek language, and in them the shapes of the letters still closely resemble Phœnician characters. Nobody has ever believed that these texts could be led back beyond the ninth century B.C.;² indeed, they are referred as a rule to the eighth, and sometimes as low down as the seventh.³ We will stretch a point and accept the earliest date, though in all probability much too old; even so we shall be obliged to suppose an interval of many years, perhaps a whole century, between the Thera inscriptions and those of the Phrygian necropoles. A century at least was needed to effect the work of elaboration and adaptation, during which the sense of the writing underwent a change; the value of some of the characters preserved was modified, others were discarded, and not a few were created.⁴ Finally the Greeks must be allowed time in which to transmit, some way or another, the use and practice of the alphabet to nations who, like the Phrygians, were not their immediate neighbours, but whom many natural obstacles separated from the Ionian and Doric cities of the seaboard. We are thus led back towards the end of the eighth century; and we reach the same conclusion through a correspondence that furnishes, so to speak, the proof of the operation, by collating and sifting the scanty data to be gleaned in history, intermingled with the brilliant tissue of fables, inseparable from Midas and Phrygia, as presented by the rich and capricious fancy of the Athenian dramatists. Thus Herodotus, in his narrative of the events which caused the throne of Lydia to pass from the Heraclidæ to the Mermnadæ, has the following:—"The founder of the new dynasty, Gyges, at first met with much resistance on the part of the friends of the old family; but the Delphic oracle having

¹ At first Professor Ramsay thought that the Phrygians had received their alphabet from the Greeks of Sinope (*Historical Relations of Phrygia and Cappadocia*, p. 27); and later, that they had derived it from the Phocæans and Cymæans, with whom intercourse was frequent and continuous (*Athenæum*, 1884, pp. 864, 865). There is this difficulty, that the Ionian syllabary would seem to have had no F, a letter largely used in all Phrygian inscriptions; hence Lenormant prefers to ally the Phrygian alphabet to that of the "islands," which would have entered the peninsula *viâ* Rhodes, where it was employed.

² LENORMANT, art. "Alphabet," p. 195.

³ S. REINACH, *Traité d'épigraphie grecque*, p. 181.

⁴ AD. KIRCHHOFF, *Studien zur Geschichte des Griechischen Alphabets*, 3rd edit., 1887, p. 53.

declared in his favour, he was able to bear down all opposition and enmity. As an earnest of his gratitude, he laid before the shrine of the Delphian Apollo rich donations of gold and silver," described at some length, and, adds the historian, "To our knowledge Gyges was the first of the Barbarians who sent gifts to Delphi, the first at any rate since Midas, son of Gordios, king of Phrygia. Indeed, Midas had consecrated his throne, that upon which he sat to administer justice, a throne fully deserving to be seen, and this throne is exhibited on the exact spot where are the crateras of Gyges;"¹ that is to say, the Thesaurion of Corinth. If, as is generally held, Gyges reigned from 687-653, Midas should come, at the earliest, towards 700 B.C.² The influence of Greek culture had been unfelt before that date in the peninsula; and nothing was known of the sanctuary that played so important a part in the Hellenic world, before the unfolding of philosophy and scepticism—a part akin to that which the papacy filled in Europe during the Middle Ages. The greatest development, physical and spiritual, ever attained by Ionia was between the latter half of the eighth and the beginning of the seventh century B.C. She had already produced that marvel, the epic poem, and, with Archilochus, she created lyric poetry. In the domain of art she was beginning to chisel Parian marble; her architects were striving to bring out of the complex and undefined shapes of the Asiatic decoration they beheld around them, the elements of their column and entablature; they even sought proportions and lines, the felicitous selection of which was to make the fortune of that noble and attractive type with which her name will ever be linked. To this splendid display of inventive genius and activity corresponds a bold movement of expansion; the cities of Ionia turned betimes their vessels towards the main, and multiplied their counting-houses from the mouth of the Phasus and the Borysthenes to those of the Nile; when Miletus, along with Tyre, becomes the great emporium of the eastern basin of the Mediterranean. The Dorian cities of Caria, the Æolian townships of Mysia, though not with equal dash, join in

¹ Herodotus, i. 14.

² The dates 687-653 are those given by Gelzer, after Assyrian documents, and should be read in his admirable work bearing the title *Des Zeitalter des Gyges* (*Rheinisches Museum*, N. F., tom. xxx. pp. 231-268, and tom. xxxv. pp. 514-528). The first portion of the paper deals with the chronology and dynasty of the Mernadæ. The work has lately appeared.

these manifold pursuits, and share the ebb and flow which attends on commercial enterprise. Built upon the shore, where its sinuous windings form natural havens, the vast majority of these centres owned but a narrow strip of land outside their walls; their population was not sufficiently large to render extension far inland advisable, for they would have run up against warlike tribes, the Carians and the Lydians, the Phrygians and the Mysians. The situation these populations held on the heights which dominate, whilst separating one from the other, the lower valleys of the Caÿster, the Hermus, the Caicos, and the Mæander, gave them the control of the fertile plains washed by these streams in their lower course. The main outlet and general outflow of the inhabitants of these maritime cities was towards the sea; but most of the commodities for home consumption, as well as merchandise for exchange, were gotten from their inland borders, and further still. In order, therefore, to procure the necessaries of life and foster their trade, they were obliged to have friends, or, as we should now say, agents, in such districts as were closed to them, and where they could not settle with any chance of success. Thus commercial and personal intercourse led the way to relations of a friendly and social nature, between the chiefs of the great Achæan houses and those of the less barbarous tribes of the tableland; similar connections were sometimes drawn closer by matrimonial alliances.

During the seventh and the sixth centuries the kings of Lydia regularly chose their consorts from, or gave their daughters to, the patrician families of Ionia. In the preceding age, ere the Lydian empire had become supreme and interposed between the townships of the seaboard and the populations located on the central plateau, the Codridæ and the Neleidæ, those presiding families of the Greek colonies, had entered into similar relations with the sovereigns of the state that subsequently destroyed and absorbed Lydia. In the seventh century, a king of Phrygia espoused the daughter of Agamemnon, king of Cymæ, celebrated for her beauty and wisdom.¹ A certain Phrygios,² a prominent

¹ Heraclides of Pontus, *περὶ πολιτειῶν* (*Frag. Hist. Græc.*, MÜLLER, tom. ii. p. 216). Pollux (ix. p. 83) calls this same woman Demodike. She must have been the wife of the last king Midas, for to her was ascribed the introduction of coined money into Cymæ, Cumæ.

² PLUTARCH, *Fem. Virt.*, 16.

personage among the nobles of Miletus, who claimed descent from Neleus, is the hero of a story which Plutarch borrowed from some old historian; now, the name in itself is proof sufficient of the friendly intercourse which existed between the sovereigns of Phrygia and the Ionian princes, whose ancestors play so conspicuous a part in the Homeric poem.¹ If the names of Gordios and Midas do not appear in Homer, that may have been due to one of two causes: either he had no opportunity for introducing them, or, what is more likely, it was because those princes did not begin to reign until after the recension of the *Iliad* by the Rhapsodists; than which no better reason could be invoked in support of the comparatively recent culture of Phrygia. Had the epic singers been contemporaries of those monarchs, some passing allusion would be found in one or other of the poems to that fabulous wealth which the fervid imagination of the Greeks ascribed to the kings of Phrygia; Midas, that Midas who turned everything he touched into gold, would seem to have been for the Ionians, before Cræsus, the type of the monarch who could draw at will from inexhaustible treasures. The *Iliad*, it is true, makes repeated mention of the Phrygians as the allies of Priam; it places some of the tribes in Ascania, a region subsequently known as Hellespentic Phrygia;² it knows of others established in the interior of the continent on the banks of the Sangarius, who wage perpetual war with the Amazons, that is to say, with an enemy from beyond the Halys.³ All are agriculturists, and

¹ It is Curtius' remark, *Hist. of Greece*, tom. i. p. 291.

² *Iliad*, ii. 860. The name of Ascania disappeared as a local designation; in the days of Strabo, however, the basin subsequently known as "Lake of Nicæa" still went by the name of Ascanian lake. One of Priam's numerous offspring, and the son of Æneas, are called Ascanius. Ascanius is a river of the Troad; the small group of islets fronting the latter are the Ascanian islands; the name is also found in a harbour situated on the Troadian and Lydian border. Ascania, according to Xanthus, was a European district, whence the Phrygians passed to Asia (Strabo, XIV. v. 29). Some hold that to have left so many traces in literary records, the name must have represented at one time the whole Phrygian people, or at least one of its tribes; an hypothesis confirmed by the fact that in the list of the sons of Gomer (Gen. x. 3), Ashkenaz, whom Lenormant would recognize as the father of the Phrygians, is placed side by side with Togarmah, the ancestor of the Armenians. The reader will find the reasons that invest the hypothesis with a great degree of probability in FR. LENORMANT, *Les Origines de l'histoire*, tom. ii. pp. 388-395.

[According to Lenormant and other authorities, Ascanios, Ascaniaus, is but the Greek rendering of Ashkenaz.—TRS.]

³ *Iliad*, iii. 184-189; xvi. 718.

more renowned for the breed of their horses and skill in breaking them than for other earthly goods.¹ Moreover, in the *Iliad*, as also in a later poem, the *Hymn to Aphrodite*,² the chiefs who head the Phrygian forces are Phorcys and Ascanios, Asios and Hymas, Otræus and Mygdon—names to which there is no need to ascribe an historical value; in the “strongly walled cities of the Phrygians,” Gordios and Midas reign not.³ The vast majority of critics hold that the *Iliad*, as we possess it, has not materially changed since the ninth century B.C. Survey of the Epos and consideration of other intelligence bring us round to the conclusion reached a few pages back, namely, that if the Phrygians were already settled in the heart of the peninsula before the time of Homer, it was not until the year 800, or thereabouts, that they succeeded in laying the foundations of that state, which was to be the most influential in Western Asia down to the day when Lydia, under the leadership of Gyges and Ardys, entered upon the scene.⁴

Tradition told of Gordios, a tiller of the soil, as the founder of the dynasty; he was succeeded by his son Midas, and from that time the two names would seem to have alternated in the royal family; they were, perhaps, those of eponymous heroes of the Phrygian tribes, fabulous ancestors worshipped as gods.⁵ Examination of the rare texts that bear upon this history permits us to make out, with more or less certainty, three Midases and four Gordioses.⁶ The number of these princes is unimportant; the one

¹ *Iliad*, x. 431.

² *Hymns*, iii. III, 112.

³ *Ibid.*, 112.

⁴ This result, to which several routes have led, is in perfect agreement with the chronology of Eusebius. He sets the beginning of Midas' reign in the fourth year of the tenth Olympiad, e.g. in 737 B.C. (ANGELO MAI, *Chron.*, p. 321). Eusebius had, it is true, put another Midas 552 years earlier, and made him coeval with Pelops (p. 291) and the foundation of Troy. All that can be urged is that the first data belong to the fabulous period of his tables, and have no historical value; whereas the second are comprised within the truly historical part of his work, when the materials he had to hand were of a very different character. The same observation applies to the date he assigns for the suicide of the last Midas (p. 324), which he places in the fifty-ninth Olympiad, clearly too late.

⁵ The fact is proved for Midas, at least, who in the west of the peninsula was confounded with one of those gods whose worship prevailed down to the last days of paganism (Hesychius, s.v. Μίδας θεός). The representations of Midas on a certain number of painted vases are only to be explained by a similar confusion of the two names. See PANOFKA, *Midas auf Bildwerken* (*Archæ. Zeitung*, iii. p. 92, 1845).

⁶ See article entitled “Midas,” *Real-Encyclop. Pauly*.

thing to be borne in mind, however, is that the Phrygian empire, after a prosperous existence of a hundred and fifty years, was ravaged (*circa* 660 B.C.), along with that of Lydia, by Cimmerian hordes. The king Midas of that day, unable to endure defeat, put an end to his existence by drinking the blood of a bull.¹ It was but a momentary calamity, which disappeared with the withdrawal of the Cimmerians; for Herodotus tells us that in the reign of Cræsus, the Phrygian king of that day styled himself son of Gordios and grandson of Midas.² The effect of the late invasion, however, had been to weaken and break up the country; so that its inhabitants offered little resistance to the Lydians when these, a few years afterwards, under the command of Alyattes and Cræsus, entered their territory, which they occupied as far as the banks of the Halys.³

Consequently, a space of two hundred or two hundred and fifty years may confidently be allowed as the duration of that Phrygian empire, which we credit with the monuments still extant around the springs that feed the western branch of the Sangarius. Strictly speaking, that state has no history, for its span of life was passed too far away from the coast. Until the day when the Greeks entered into intercourse or conflict with Lydia, nothing was known on the coast of the events that were taking place on the plateau. The scanty data we possess as to this empire relate to events which may be dated with certainty within a few years; landmarks, such as the reign of Gyges, the Cimmerian incursions, the wars of Alyattes and Croesus. Gordios, Midas, together with the monuments situate on the western rim of the great plateau bearing their names, belong, then, to what may be termed the historical period. We are better off in regard to another kingdom, which likewise left recollections of its power and wealth in the mind of the Greeks; we allude to a state skirting the Ægean, whose capital, fastnesses, and sanctuaries rose on the flanks and within the gorges of Sipylus, between the valley of the Hermus

¹ Strabo, I. iii. 21. Allusion to this suicide will be found in PLUTARCH, *Flaminius*, 20.

² Herodotus, i. 35, 45.

³ Herodotus (i. 28) ascribes to Cræsus the subjugation of the peninsula to the banks of the Halys; but Alyattes must have commenced it, since a little further (i. 74) he shows him carrying on a war of six years' duration against Cyaxares. The valley of the Halys and the central plateau were doubtless the scene of this struggle; there is nothing to indicate that the Medes of that date went near the Mediterranean.

and the Smyrnian Gulf. As time rolled on, these heights were abandoned for the level plain below; populous cities, as Magnesia, were built in the plain, or on the shore, as Smyrna. But Sipylus, even when deserted, did not lose its hold on the regard of the natives; it continued to be venerated as the favourite abode of the great Asiatic goddess, Rhea or Cybele. The monuments, left by generations that had been the first to cast the seeds of civilization on a soil from which Greek genius was to reap such splendid fruit,¹ were visited with pious curiosity; but they elicited no questioning as to their chronological order, and whether due to one or several epochs.

The traditions relating to this commonwealth had assumed a mythic form; they led back to that fabulous age when gods descended upon earth and lived in intimacy with men; they clustered about two single names, those of Tantalus and Niobe, whose transcendent magnificence and insolent prosperity had roused the wrath of jealous deities, and caused their headlong fall. Then, too, had followed catastrophes as sudden as they were strange; earthquakes had shaken the mountain to its very base; yawning chasms had engulfed the royal city of Tantalus, with her prince and inhabitants, and amidst the crash of falling boulders streams had gushed forth from the abyss, and where once had been the proud city, stood now a lake, in whose waters at low tide the ruinous mass of palace and dwellings could be descried.² The legend of Niobe, daughter of Tantalus, whose numerous and happy offspring are all struck down, may be taken as foreshadowing the ruin of a brave and proud community, suddenly blotted out of the roll of nations by the wholesale massacre of its male adults.

Many are the variations of the myth of Tantalus and Niobe;³

¹ This is implied by Pausanias, who returns again and again to the curiosities of Sipylus, often in the following words: "As I myself saw on Sipylus."

² The *Odyssey* (xi. 582) puts Tantalus in Tartarus, but does not say to what misdemeanour he owed the famous punishment that goes by his name. PINDAR (*Olymp.*, i. 54-64) indicates as his crime the theft of nectar and ambrosia. On the destruction of Tantalus or Sipylus by an earthquake, see ARISTOTLE, *Meteorologica*, ii. 8; Strabo, I. iii. 17; XII. viii. 18; PLINY, *H. N.*, edit. Littré, ii. 93, v. 31. Pausanias writes that in his day the ruins of Tantalus were still to be seen in the depths of the waters (VII. xxiv. 13).

³ These various traditions have been collected in book form, and discussed by K. B. STARK, *Niobe und die Niobiden in ihrer literarischen, künstlerischen und mythologischer Bedeutung*, 464 pp. and 20 plates, 8vo, Leipzig, 1863.

the form given here is that which has found general popularity and acceptance. Among the various readings that have come down to us, one alone indicates, implicitly at least, the epoch to which the Greeks carried back the reign of Tantalus, and the dominion he exercised over the country that stretches from Sipylus to Ida; it represents Ilus, Ilos, Ilium, a prince of the Dardani, the founder of Ilium and grandfather of Priam, as having overthrown Tantalus and destroyed his empire.¹ To accept as sober fact the story according to which Ilus, to avenge his brother Ganymedes, had led a great force against Tantalus, is out of the question; but the tale suffices to prove that a far more remote antiquity was ascribed to Tantalus and his kingdom on Sipylus, than to the Phrygian empire of the Sangarius. For the chroniclers, to put an event generations before the Trojan war, was equivalent to relegating it away to that shadowy past, ere men had taken count of time.

If such traditions stood by themselves, they might be deemed of little moment; but it so happens that they are in perfect agreement with the monuments. Three of these rock-sculptures found in the Sipylus region have already been figured and described in the fourth volume of our history; namely, the two bas-reliefs at Karabel, and that colossal statue of Cybele, which for a long time was taken as a Niobe.² These works, it will be remembered, were assigned by us to the oldest civilization of Asia Minor, that which we designated as Hittite or Syro-Cappadocian; we based our assumption on similarity of type, style of workmanship, and graphic signs, which distinguish both these and the monuments of the basins of Orontes and the Halys.³ On the other hand, nowhere in this district has the slightest trace been found of an alphabet derived from the Phœnician,—that which the Phrygians of the valleys of the Rhyndacus and the Sangarius borrowed from the Greeks when they wished to write their language; equally non-existent are those principles of ornament seen on the Midas monument, and the surrounding sepulchral façades. Had we no historical witness the mere sight of these monuments would enable any one of average intelligence to assign priority of date to the city and the culture of the population dominated by the rounded summits of Sipylus. To be noted

¹ Diodorus, iv. 74.

² *Hist. of Art*, tom. iv. Figs. 361, 363, 365.

³ For the signs in question, see *Ibid.*, Figs. 364, 366.

also on these denuded slopes, will be other remains of a far-off past, consisting of bas-reliefs, structural and rock-cut buildings; which, though less striking and characteristic than the two pseudo-Sesostris and the Cybele, have, in our estimation, all the marks of high antiquity.

The difficulty is to find out to what branch of the human family belonged the race that has left so many marks of its existence and activity on the flanks of Sipylus. Is it necessary to attribute everything to those conquerors from the East, whose image we think we recognize graven on the rocky sides of the pass they carried with their arms? We trow not. The brave soldiers who measured their strength with Egypt, not always to the advantage of the latter, may, at the time when the superiority of their military tactics and armament ensured their undisputed supremacy in the western portion of the peninsula, have carried the point of one of their columns as far as here. But it is difficult to imagine that they remained long so far away from the Taurus, both slopes of which they occupied. Now, taken altogether, the monuments met with on Sipylus seem to testify to the long sojourn of a settled population. Near Magnesia, around the statue of Cybele, are altars and niches which in their turn testify to the homage paid to the gigantic idol from the day of its birth, and for centuries afterwards. On the lower hills, turned towards Smyrna, are stairways and galleries, redoubts, places of worship, and tombs, all of which are partly built, partly hewn in the rock. One and all tell, as clearly as possible, that a people lived for many generations entrenched on these heights, but that when the Greek cities were founded on the adjacent shores, this same people had already lost whatever importance they had previously possessed; since epic and lyric poetry are alike silent about them, save their having once been mighty enough and rich enough to kindle the jealousy of the gods. The curiosity of the historian, which should not be so readily satisfied, but would seek to penetrate further, will have little more than a choice between two hypotheses. That of a Hittite colony established at some time on Sipylus is in itself very improbable; for no indication, however slight, can be produced in its favour either from history or legend. On the other hand, if already in the day of Herodotus the name of Phrygia Major, Great Phrygia, was confined to the elevated region stretching between the Halys and the Sangarius, the Rhyndacus and the

Mæander, a distinct impression was retained of a far-off age when the Phrygians had spread high up around the Mysian Olympus, the Idæan summits, and Sipylus. In the time of Strabo the name of Phrygia Parva, Small Phrygia, or Phrygia Epicteta, was still generally applied to the country ruled by these mountains.¹ It was an indefinite name, and answered to no existing division, yet is of great interest to us as a reminiscence of the old Phrygian empire, in that it serves to prove its extension to the Bay of Smyrna. We have a further proof of this in a passage of Strabo, where he expounds the difficulties that beset the historian who should try to fix the boundaries of the Phrygians and the Mysians: "This," he goes on to say, "is proved by the name of Phrygia, given by the ancients to the region of Sipylus itself. . . . They also called Phrygian Pelops, Tantalus, and Niobe."²

If, as universally held by the ancients, the Phrygians came from Europe across the straits to Asia Minor, it is natural to suppose that, once on the Asiatic side of the Bosphorus and the Hellespont, they tarried a while ere they ventured on to the thickly wooded heights of the interior; they would begin to spread along the comparatively clear coast, especially towards the south. In continental Greece, too, at the same time and in the same fashion, other Thracian tribes, following the chain of Pindus, reached Bœotia and Attica. The Phrygians would thus have pushed on to the rich plains which we know as Lydia, as far as, yet not further than, the Bay of Smyrna; since the southernmost territory specified by Strabo as within the Phrygia of the coast, which he distinguishes from Mediterranean Phrygia, is the district of Sipylus.³ The more advanced post occupied this fort-like mass, which

¹ Strabo distinguishes (XII. viii. 1) "what is called Phrygia Major, the ancient kingdom of Midas, part of which has been occupied by the Galatians," from "Phrygia Parva, or, as it also is called to-day, Phrygia Epicteta, which extends along the Hellespont and Mount Olympus." The term *ἐπίκτητος* is of recent origin, and only dates from the kings of Pergamos; it designated the province these "acquired," in reality wrested, from the kings of Bithynia (Strabo, XII. iv. 3).

² *Ibid.*, viii. 2. So Athenæus, who, together with the whole antiquity from Homer, regarded Pelops as the son of Tantalus, states that within Peloponnesus are the tombs: τῶν μετὰ Πέλοπος Φρυγῶν (xiv. p. 626). Sophocles (*Antigone*, 825) calls Niobe: τὴν Φρυγίαν ξέναν Ταντάλου.

³ Nevertheless, mention is made of Mydonians as inhabiting the neighbourhood of Miletus (*ÆLIAN.*, *Hist. Var.*, viii. 5); of Bebryces, who, together with the Phocæans, would seem to have been engaged in holding in check the surrounding barbarous tribes (*POLYÆNUS*, *Strateg.*, viii. 37).

commanded at once the fertile valleys of the Hermus and the tranquil waters of a bay never stirred by the breeze. The advantages of such a situation as this ensured prosperity to the new kingdom, which was further increased by the winning of rich ores from rocks upheaved and fashioned by Plutonic agency. The wealth of Tantalus, rumour said, had been due to the mines of Sipylus.¹

The art of mining and working metals was not learnt in Asia by the Phrygians; when they quitted Europe they were still a barbarous race. Those tribes that were left in the parent home of Thracia, around the Pangæus and Hæmus, were little better than savages at the time of the Roman conquest. If matters took a different turn with the children of that family who had settled in the Anatolian peninsula, it was because they were from the outset brought in contact with a more advanced people, one with the command, in part at least, of the processes that had long been the boast of the Egyptian and Chaldæan civilizations. These intermediate initiators and teachers were no other than the Hittites; those brave soldiers and ready inventors who had carried their arms and the use of their writing from the banks of the Euphrates and Orontes to those of the Ægean, from Carchemish and Hamath, even to the regions where later rose Smyrna and Sardis, Ephesus and Miletus. On many a point of the vast tract comprised within these boundaries, we have found unmistakable traces of the military power and creative energy of the Hittites; in Cappadocia and Lycaonia, for instance, are notable remains often of gigantic size, and in Phrygia and Lydia isolated figures carved on the native rock, with short inscriptions as yet undeciphered; everywhere, in short, east and west of the peninsula, we met with small objects, trinkets and seals, on which appear forms and types derived from Northern Syria. Instances such as these prove that Syro-Cappadocian culture, after having opened up the western highways with might and main, used these strategic routes for the purposes of trade, and guarded them by means of fortified posts, as we have seen at Ghiaour Kalessi.² One of these roads, taken by caravans, led to

¹ CALLISTHENES, *Fragm.*, 29 (*Scriptores rerum Alexandri*, collected by Ch. Müller, and placed at the end of Arrian's work, collect. Didot). Hence the Greek dictum, Ταντάλου τάλαντα (*Thesaurus*, s.v. ταντλίζω).

² *Hist. of Art*, tom. iv. vol. ii. p. 714, Figs. 351, 352.

the Karabel Pass, where it divided: one running down to the furthest point of the bay, the other debouching into the marvellous plain of Hermus. If we have correctly made out the stages and guessed the terminus of this highway, would there not be ground for believing that, at the point where it reached the sea, a mart of exchange, both for merchandise and ideas, would almost immediately have sprung up; and should not this be the explanation of that precocious prosperity with which legend endowed the Tantalus of Sipylus, the proud city overthrown by Zeus, as elsewhere Sodom and Gomorrha were destroyed by Jahveh?

On this hypothesis Tantalus and his subjects would be Phrygians, as said tradition, but Phrygians formed in the school of those eastern conquerors whom we have tentatively called, to give them a name, Syro-Cappadocians or Hittites. Are commercial relations enough to explain borrowings and progress, or did the Hittites in their victorious march penetrate as far as these shores which unlocked the sea to them? Did they occupy for a time Sipylus, plant a colony there, a kind of outpost, whose population in due time intermingled with such of the Thracian immigrants as had been brought to these same slopes and ravines? Neither myth nor history will answer the question. The monuments of this district, however, exhibit features other than those seen on the examples of the upper valley of the Sangarius; they look older, and are directly derived from the art which created the sculptures of Pteria and Lycaonia. But for the enormous distance intervening between Sipylus and the Amanus and Laurus range, one would be tempted to attribute them to the Hittites. This we have done for the twin figures at Karabel and the Cybele near Magnesia; but when the reader, along with us, climbs the rugged sides of Sipylus, and discovers other very archaic works, will not the question arise as to whether all these, even to the Pseudo-Sesostris and the false Niobe, should not be assigned to the Phrygians of Sipylus rather than to transitory invaders? To these may belong figures whose outward signs and the place they occupy would lend themselves to such explanations; but there are difficulties not easily overcome in ascribing to hands other than those of the permanent inhabitants themselves, a work which, as the Cybele, Buyuk Souret, clearly shows long and patient labour. Our reason for including the Buyuk Souret with the Hittite series was (1) to make it as complete as possible, (2)

because of the inscription accompanying it. It would have been wiser, perhaps, not to have detached it from the monuments that constitute the Sipylus unit, a group that would represent the effort and legacy of the first civilized state ever planted on the western coast of Asia Minor, within easy reach of the Archipelago, having the Hellenic peninsula right opposite. Of course, the Phrygians of Sipylus were not the first inhabitants of the line of coast that faces towards Europe. Before the influence of Eastern arts and industries had travelled thither, the physical and climatic conditions of this favoured land had attracted around the springs and mouths of rivers populations made up of pretty closely packed settlements. To inquire their name and origin would be vain, since history, nay, not even tradition itself, could travel so far back. The existence of these truly "prehistoric" populations, in the fullest sense the term implies, has been revealed to the world by the recent excavations of Dr. Schliemann in the Troad. From the bottom of the trenches opened in the sides of the hill at Hissarlik, was brought out a "stone civilization," if the expression may be allowed. Now, among the implements of every description that lay heaped together in the lower strata, dropped there by each generation in turn, no metal has been found; at least so rarely, that where its presence has been detected, we may reasonably set it down to accident—either some mistake in making up the journal from the notes, which may have got confused, or the falling in of a portion of an upper layer or crust, causing the regular order to be disturbed, so that articles that properly belonged to recent, or *at least much later* times, would be found in the lowest layers amongst the primitive ones. As to celestial types and ornamental forms of Egyptian and Chaldæan origin to be found almost everywhere, both on the coasts and the Mediterranean islands (whither they were carried by the Phœnicians), or distributed in the interior of Syria and Asia Minor by other intermediaries, they are non-existent at Hissarlik; at any rate, in pieces of genuine antiquity, such as unquestionably belong to the lowest strata. Here art and industry, though rude, betray independent effort; an effort akin to that which inspired the populations of the Ægean coast in their first struggles to emerge from barbarism, ere a double set of influences borne by land and sea put them in continuous touch with the civilized nations of Further Asia. A careful

survey of the industrial products of the primitive art under notice, will form a natural introduction to the history of Hellenic art; we will call at Hissarlik on our way to Mycenæ and Tyrins.

In the race we promise to run, we are bound to complete our study of the productions of Oriental art ere making that turn of the road where lies Greece. That thousands of years divide the civilizations of Egypt and Chaldæa from those that unfolded later on the European side of the Mediterranean, is a fact we have tried to make clear; going back as far as possible to that mysterious past, whose far-reaching depths were unsuspected till yesterday. Thanks to recent researches and discoveries, the main results of which have appeared in our history, we are now able to measure the importance and originality of the work accomplished by the first civilized nations of the valleys of the Nile and of Europe. The course of our studies took us to the capitals where these nations had reared monuments both imposing and numerous; to Memphis and Thebes, Babylon and Nineveh, Tyre and Sidon. We saw by what means the methods invented by these active and influential centres were disseminated in an easterly direction. It remains to trace the effect of such teachings and example upon peoples who, although they never played a leading part in the world, contributed none the less, in a greater or less degree, to work up the materials which Asia transmitted to Europe. Hence the fitness of taking up each in turn, Phrygians, Lydians, and Lycians. These people lost their independence towards the beginning of the seventh century B.C., when they became subject to the Achæmenidæ. The result of this conquest was to bring democratic Greece into contact with the greatest Asiatic monarchy the world had yet seen, whose art, the youngest and the last derived from Oriental tradition, will form the larger portion of this volume. It is an art which, in the building and decoration of its monuments, could dispose of almost boundless resources; it will, therefore, detain us longer than those provincial and secondary arts, whose claim to our early attention lies in the fact that they stand first in chronological order.

In obedience to this principle we shall begin with the Phrygians, whose mythical cycle, often referred to by us, shows them as a compact political body in the days of Homer, to whom the name even of the Lydians is unknown. Our survey of Phrygian art will divide itself in two sections—one devoted to the monuments

of Sipylus or Phrygia Parva, which, as a kingdom, had already ceased to exist when epic poetry had its birth; the other to those of that state of Phrygia Major, the last rulers of which belong to historical times. In this second group will be included a certain number of tombs recently discovered in Paphlagonia; here and there, north and south of the chain of Olympus, the arrangements in sepulchral architecture are precisely similar, at least in those tombs that are prior to the introduction of the Greek language and Greek arts into the centre and north of the peninsula. Were the Paphlagonians sprung, like the Phrygians, from a Thracian stock? We know not, save that the resemblance between the two sets of monuments seems to justify the comparison we have made.

CUSTOMS AND RELIGION OF THE PHRYGIANS.

The historian who desires to form a fair idea of the general culture, religious creed, and public worship of Phrygia is obliged in a great measure to rely upon authorities of comparatively recent date, unconnected, it would seem, with the period within which we wish to confine ourselves for the present. Such a course is justified by the oft-repeated statement, which will bear being mentioned afresh, namely, that Hellenic culture did not penetrate to, or take permanent hold on, the interior of the peninsula until the days of Alexander and his successors. And though its diffusion was universal and lasting, it proved ineffectual in stamping out the religion, legends, and usages, hallowed by a past so remote as to be counted by thousands of years. Hence it comes to pass that even the Greeks, in matters pertaining to religion and art, were actually influenced by the order of things they beheld around them. Under Roman rule, the temples of Pontus, Cappadocia, and Phrygia, of Bela, Comana, and Pessinus, to name only the best known, along with the lands attached to them, preserve a whole host of eunuch-priests and consecrated temple-slaves of either sex. The yearly festivals, which were wont on stated days to attract thousands of pilgrims to worship at the shrines, are as fully attended as of old. No need is there to rejuvenate or bring them up to date; their title of nobility and claim to the reverence of the multitude reside in their antiquity. Then, too, in many a sepulchre of old Phrygia, dating from the first and the second century of the

Christian era, imprecatory formulas continue to be incised, to scare away the impious who should presume to disturb the sacred repose of the dead.¹

If the social conditions of the people in possession of the coast line of the Ægean were scarcely disturbed by the Macedonian and the Roman conquests, there is every reason to suppose that the old order of things was maintained during the Persian rule, which lasted two hundred and fifty years. Under the name of satraps, the heads of local dynasties preserved, almost everywhere, their hereditary power, and priests continued to preside over their theocratic principalities. Despite the apparent disappearance of ancient divisions, the various races who occupied the tableland were allowed to live their own life, subject to paying a small tribute and furnishing a certain number of soldiers in time of war. No government was ever found to govern less than that of the Achæmenidæ, nor was its policy ever directed to control the liberty of action of its subjects, who were left to work out their weal or woe unfettered. When we come to examine the monumental façades which are so plentiful in the cemeteries of Eastern Phrygia, we shall find that they continued almost unchanged during the space of about five hundred years, beginning from the eighth century B.C., down to, perhaps, the Seleucidæ. As time rolled on, Greek influence becomes perceptible in the proportion of columns, the shape of capitals, the character and make of entablatures, without prejudice, however, to the main dispositions or decorative themes, which are precisely the same as in the age of Gordios and Midas. It is a trite remark that religious conceptions, inasmuch as they are implanted in the inmost soul, offer a far greater persistency than artistic forms, no matter how beautiful or ancient, easily imitated, too, or borrowed. In Phrygia it took a very long time to bring about modification and change in existing forms, which were with difficulty replaced by fresh ones. If this

¹ The real significance of these formulas was first understood by Moritz Schmidt (*Neue Lykische Studien*, pp. 132-136). See also Professor Ramsay's recent dissertation, entitled "Phrygian Inscriptions of the Roman period" (*Zeitschrift für vergleichende Sprachforschung*, N.S., tom. viii. pp. 381-400). The formulas in question are more particularly found east and north of Phrygia; that is to say, far from the boundaries of Ionia and the district subsequently called the kingdom of Pergamus. These territories were, from the outset, marts of exchange, and, so to speak, the focus of the electric contact between Phrygians and Ionians; hence they became closely united together, nay, blended into one community, Greek in speech.

be so, how much more sedulously must observances relating to the public worship of deities have been watched over and preserved as relics bound up with the instincts and early awakening of these primitive societies? Contact with Greek polytheism did not materially affect the religions of Asia Minor or Syria, which kept their ground far more energetically, and were more successful in repelling alien influences, than those of the Italians and Gauls. This they owed to their intense spirituality; for, although they were acted upon by the new religion, they reacted and gave back in their turn quite as much, if not more, than they had received. Consequently, in trying to unravel the inner meaning and outward form of these cults, we may unhesitatingly draw from authorities acknowledged as such, Herodotus, Strabo, Diodorus, etc., as well as from later ones, who, when Greece ceased to create in the domain of art and poetry, set themselves to write the histories of the Hellenic race and of the various peoples who had preceded them in the country. In so doing they made use of the accumulated data which lay open to them at Pergamus and Alexandria.

The Phrygians were distinguished from their neighbours of Lydia, and the Greeks on the coast, in that they were essentially a nation of shepherds and husbandmen. From the earliest time they partially cleared out the forest-clad mountains, to feed numerous flocks and herds, which constituted one main source of the revenue of native princes, as it does to the present day. This was forcibly borne home to us as we sat at the door of our tents and watched the kine and yearlings roaming under majestic pines, or as we journeyed along the banks of the Sangarius, around its copious springs, which give the river from the outset a considerable volume of water, and render it unfordable save at rare intervals. If in summer herbage is scanty on the plateau, an abundance of grass is always to be had on the first slopes of the hills. Homer extols the fiery steeds foremost in the chase led by the Phrygians (*Iliad*, ii. 862; iii. 185; x. 431; *Hymns*, iii. 138). Close at hand, Pan engaged Phœbus in unequal contest, when public opinion, as was to be expected, declared in favour of the greater god, and honest but imprudent Midas withdrew with ass's ears (OVID, *Metam.*, lib. xi., iv.¹). However this may be, the same god

¹ The reference given is according to English arrangement, and not that which appears in the text.—TRS.

reappears later under the name of Atys, the chief deity of the Phrygians, whom tradition depicted as a fair young shepherd of whom Cybele was enamoured.¹ Other instances might be added in proof of the rural bent of the Phrygians; their readiness in turning to account the natural fertility of the soil, which in many places is a soft tufaceous rock, easily disintegrated, and of marvellous productiveness. With them all that related to husbandry was deemed sacred: the husbandman, the ploughshare, and the patient oxen yoked thereto were under Divine protection. Death was the sentence passed upon the evildoer who misappropriated implements of husbandry or killed a plough ox.² The gold-plated chariot of their great ancestor, Gordios, had not been a war-chariot, but a lumbering cart which served him to garner his crops;³ the plating had been of later days, so as to render it a fit offering to Olympus. Had not he commanded his winged messenger, the eagle, to alight on the yoke of Gordios's team, as an earnest of his future power? This was no other than the famous chariot placed in the Thesaurion at Corinth by his son Midas, and doubtless very similar to the clumsy *arábas* of the present day.⁴ Then, too, the fabulous wealth of Midas had been foreshadowed in grains of wheat, carried by ants to his infant lips;⁵ whilst his gigantic son, Lityerses, a king among reapers, gloried in the stoutness of his sinews, and overthrew everybody whom he challenged to single combat. His name it was which resounded in song in the lowlands at harvest time, or around the threshing-floor.⁶ Others, again, were connected with the vintage, where Midas appears as filling the fountain, out of which Silenus is wont to quench his thirst, with the juice of the grape, so that the unsociable old man may be secured whilst overpowered by the unusual libation.⁷

Allusions to the potency of wine, its cheering effect on the hearts

¹ In a poem of Atys, partly reproduced by Origen (MILLER, *Philosophumena*, p. 119), he is called *αἰπόλος*, goat-herd; whilst Theocritus (xx. 40) calls him *βουκόλος*, ox-driver.

² Nicholas of Damascus (*Frag. Hist. Græc.*, tom. iii. p. 128, Müller's edition).

³ ARRIAN, *Anabasis*, ii. 3; ÆLIAN, *De natura animalium*, xiii.; Q. Curtius, iii. 1.

⁴ *Arába* is the Turkish name for a chariot drawn by oxen.

⁵ CICERO, *De Divinatione*, I. xxxvi.

⁶ Athenæus, x. p. 415, B; xiv. p. 419, A.; THEOCRITUS, *Idyls*, x. 41; Pollux, iv. 54.

⁷ XENOPHON, *Anabasis*, I. ii. 13; Pausanias, I. iv. 5; Maximus of Tyre, XI. i.; PHILOSTRATES, *Life of Apollonius*, vi. 27. ARNOBIUS (*Adversus gentes*, v. 6) relates the same story of Agdistis, whom Dionysius overpowers with a generous vintage by the same means.

of God and man, abound in the Homeric poems, and prove the high esteem in which vine-culture was held; nor was there lack of flesh, which the Phrygians consumed in prodigious quantities, of milk and fruit, and of such rude comfort as is to be found in primitive communities (*Iliad*, iii. 401; xi. 184, etc.).

The Phrygians do not seem to have had a taste for warlike adventures or commercial transactions involving long voyages. They were content to sell their raw products, including, perhaps, metals, gold and silver, found on many a point of their territory; especially gold dust washed down by rivulets flowing down the rocky mountains. This it was which, as with their neighbours, the Lydians, gave "royal power to their kings;" and though they obeyed a military chief, they remained to the last a quiet, unoffending people. Thus it came to pass that, despite the strong position afforded by their hilly country, they fell an easy prey in turn to the Cimmerians and Lydians. Albeit accounted of slow understanding by their quick-witted neighbours, they could boast a mighty past, and were the first inland tribes that made use of an alphabet derived from Phœnician letters. They left no literature; but neither did their neighbours, the Lydians and Lycians, whose political existence was more brilliant, and extended over a longer series of years. Their writing, however, is known from the inscriptions already referred to. The substitution of the Greek for the Phrygian language was effected in the time of the Seleucidæ. The writers of that day, struck with much that was new and quaint in the narratives recounted to them, set about noting down the chief events and first struggles towards greater light—at least, as they appeared to them—of the beginnings of the people with whom they had become connected. In so doing much that it were interesting to know, myths, details connected with their religion and history, were rejected as rude and uncouth, altogether unworthy to figure in their pages; whilst many a fact was distorted or softened down to suit their prejudices. Nevertheless we are too severe in our strictures against the Greeks for the part they played in the reviving and editing of the folk-lore of these inland tribes, forgetting that without them the literary monuments in question would never have been heard of.

If the written records of the Phrygian nation consist of but a few obscure texts graven on stone, their tombs show them to have been possessed of genuine talent for plastic art. Were these non-existent,

however, the nature of their legendary lore would be enough to prove their rare artistic gifts. They certainly were a vigorous, impassioned race, whose imagination, by turn graceful, tender, melancholy, and lively, is reflected in the myths which go by their name. They were great lovers of music, and, as the inventors of the flute, gave proof of real originality of mind. If not the first who had brought sounds out of the reed, as the Hellenes said, they had shown how much could be made of the simple instrument. On the margin of Lake Aulokrene, "the spring of the flute,"¹ it was further alleged, hard by Kelænæ, grew reeds of superior quality, emitting the most resonant sounds.

The close relationship between Armenians and Phrygians has been referred to; now, in the Armenian language *elegen* signifies reed, a word Greek lexicographers were unable to explain, albeit rendered familiar to them from about the seventh century B.C. by the *elegos* (whence elegy), poems of Callinus of Ephesus, and Archilochus of Paros,² which were heard throughout the cities of Ionia with due accompaniment of the flute. The Greeks passed readily from one mood to another, and took great delight in opposing the lyre to the flute; the deep dulcet tones of the former lulled the soul, whilst the shrill penetrating notes of the latter excited the nerves to quick resolve, often to deadly strife.³

¹ DUNCKER, *Geschichte des Alterthums*, tom. i. p. 384. BERNHARDY (*Grundriss der Griechischen Litteratur*, § 101, nn.) discusses at length the more or less absurd derivations put forth by Greek grammarians, in their vain attempts to prove the Greek origin of ἔλεγος. He is of opinion that it was an old Asiatic word, the real meaning of which was lost in its passage across Asia Minor and the Ægean. BOETTICHER (*Arca*, 34) derives ἔλεγος from *elegn*, reed, and *elegnery*, a flute made of reeds. On the other hand, HANS FLACH (*Geschichte des Griechischen Lyrik*, etc., 8^o, 1883, tom. i. p. 158, note 2) connects ἔλεγος with a different group of Armenian words: *jegern* or *jelern*, misfortune; *jejerakan*, *jelarakan*, tragic, fatal, whence elegy, funeral song, to weep, to lament, etc. In our estimation Boetticher's theory, which would connect *elegos* with flute, is more likely to be right; for the word, at the outset, had not the exclusive meaning of plaintive poetry, and *elegn* comes nearer *elegos* than *jelern*, *jejerakan*, and the like adduced by Flach. The hypothesis, too, is more consonant with what we know of elegiac poetry, in which Callinus (778 B.C.), Archilochus (685), Tyrtaeus (684), Mimnermus, and Solon (558) excelled. Elegy was sometimes melancholy and mournful, sometimes amorous and martial; used, too, by moralists and politicians to air their ideas, or explain away their public action. The themes might be divergent, but the rhythm never varied, and as long as such pieces were sung, it was to music expressly composed for the flute.

² ARISTOTLE, *Politica*, VIII. vii. 8, 9.

³ PLATO, *Republic*, iii. p. 399.

Each style of music had its partisans: Apollo led the choir of the lutists, and Pan and Marsyas were faithful to the native reed. Our duller northern sense is slow to grasp how impressions so wide apart, yet alike in their mastery, should have been aroused in the breasts of the ancient Greeks, albeit most of us can feel the difference of tone produced by wind or string instruments. Whether due to the complex and scientific character of modern music, certain it is that, except to southern nations who have retained much of the impressionable nature of primitive societies, it no longer is an all-engrossing force, a subjugation of the senses as irresistible and as much to be dreaded as inebriation.

The supreme sway music is apt to exercise over the impressionable mind of youth was fully acknowledged and taken into account by ancient philosophers in their educational plans. Plato banishes the flute from his ideal Republic;¹ and Aristotle² is of opinion that the young should not be exposed to music of necessity married to the captivating strains of elegiac verse which in his day still went by the name of Phrygian, as likely to lead to self-indulgence and debauchery of the worst kind. Nor were their apprehensions ill founded, for the melodies played on the flute bore strong and unmistakable signs of their origin; of having sprung up in the frenzied transports of public rituals to which the Greek gave the name of "orgies," and which were associated with the cults of Thrace, Syria, and Asia Minor.

The religious belief of Phrygia was but the worship of the powers of nature; its festivals were a sacred drama, the subject of which was the eternal struggle between life and death, light and darkness, youth and decay. Upon this theme a rich fancy rang the changes according to time and place. The waxing and waning of the moon, the revolution of the glittering spheres, the rising of the sun, its daily sinking below the horizon and its disappearance in the gloom of night, are phenomena well calculated to strike terror in the imagination of primitive man. Experience enables us to view with equanimity, if not with indifference, the varying phases of the complexes that sum up the universe. But it was not so in those early days, and we can imagine the anxiety with which men watched the rapid succession of the seasons in a region of climatic extremes. But yesterday the tableland lay under a

¹ PLATO, *Republic*, iii. p. 399.

² ARISTOTLE, *Politica*, VIII. vii. 8, 9.

white covering of snow, which the wind took up, tumbled about and cast from the heights, it being arrested by fretted rocks on whose surface the dust of summer still adheres. The moisture, helped by the sun, quickens even the bare stone, and covers it with soft green and a profusion of flowers which expand in the air their sweet perfume.

This is not the place for attempting to unravel the confused mass of the mythic cycle of Phrygia, which we only know in the garbled account of the Greeks, whom it moved to laughter, or the still more distorted version of Clement of Alexandria and Arnobius.¹ Yet all was not puerile, fanciful, and obscene in these myths as held by the fathers, for, despite multiplicity of names and whimsical variants applied to the same personage, we can go back to the time when the religion of these inland tribes was centred in a divine couple—a solar or god of heaven whom they worshipped as Papas,² father, whom the Greeks identified with Zeus, and a goddess, Ma, Amma, mother (Rhea, with the Romans), the personification of the earth.³ Great reverence was paid to the female deity, in her character of goddess-mother, and the first place was assigned to her in all public festivities, contrary to the custom which prevails with people of different race. This was no other than Cybele, whose altar, accompanied by an inscription now

¹ In our account of the Phrygian religion we have followed M. A. MAURY, *Hist. des religions de la Grèce antique*, tom. iii. pp. 79-100; as well as DUNCKER, *Geschichte des Alterthums*, tom. i. pp. 338-390; ED. MAYER, *Geschichte des Alterthums*, tom. i. p. 253; and FRANÇOIS LENORMANT, *Sabazius* (*Revue Arché.*, N.S., tom. xxviii. pp. 300-389; tom. xxix. pp. 43-51).

² Arrian tells us that the Bithynians, who are nearly related to the Phrygians, call Zeus Papas: ἀνιόντες εἰς τὰ ἀκρὰ τῶν ὄρων βιθυννοὶ ἐκάλουν Πάπαν τὸν Δία (*Bithyn.*, EUSTACHIUS, p. 565, 4). See also Diodorus Siculus, III. lviii. 4, who states that Atys was addressed as Papas in after times by the Phrygians.

Two names, supposed to have belonged to ancient towns whose site is unknown, are compounded with the form Manes; Manegordion, Manesion. Inscriptions and statues in honour of Men are plentiful during the Macedonian and Roman period throughout the peninsula. With regard to this god, his cult, and many appellations, consult GUIGNIAUT, *Religions de l'antiquité*, tom. ii. p. 962, and more especially WADDINGTON, *Voyage Arché. Le Bas*, v. Nos. 667, 668.

³ *Etimologium magnum*, s.v. Amma; Stephanus Byzantinus, s.v. Mastaura, name of a Lydian town. Ἐκαλεῖτο δὲ καὶ ἡ Πέα Μᾶ καὶ ταῦρος αὐτῇ ἐθύετο παρὰ Λύδοις. Μᾶ was likewise understood in the sense of mother by the Greeks. Μᾶ γᾶ, Μᾶ γᾶ (μήτηρ γῆ) is found in ÆSCHYLUS, *Suppl.*, 890-899. Μήτηρ ὄρεια, μήτηρ ἰδαία (Strabo), *Phrygia mater* (Virgil), were exact transliterations from the various names borne by Cybele in her Phrygian home.

obliterated, has been discovered by Professor Ramsay. Fortunately for us, however, the two initial words, "Matar Kubile," written in sunk characters, can be easily made out (Fig. 3).¹

Next in popularity and importance was the lunar god Men, whose cult spread throughout Asia Minor, and thence to Greece and Rome.² Statuary generally represents him as a man of youthful appearance.³

Greek and Latin writers, to whom we owe the little that is known of the Phrygian religion, mention, in relation with Cybele, a god whom they variously call Bagaïos, Sabazius, Atys, and Agdistis.⁴ That names so widely different should be applied to the same personage is rather puzzling at first; but philology will perhaps help us out of the difficulty. If, according to the best authorities, words said to belong to the Phrygian idiom admit of being explained by Indo-European roots, Bagaïos was simply a generic term for god;⁵ Sabazios, Sabazius, a eulogistic epithet signifying venerable, worthy of adoration.⁶ The real and proper name of the god was Atys or Agdistis. Atys may be a dialectic variant, an abbreviation of the older and more complete form of Agdistis,

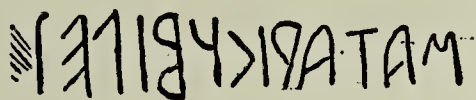

FIG. 3.—Phrygian inscription. RAMSAY, *On the Early Historical Relations*, Plate III.

¹ There is also the form Cybele, sometimes found in Greek lexicographers and in inscriptions of this goddess, which, like Fig. 3, seems to indicate a late modification of the name.

² Among the Thracians, who owned community of blood and religion with the Phrygians, Sabazius is a solar god (MACROBIUS, *Saturnalia*, i. 18). The great Phrygian deity was styled ποιμήν λευκῶν ἄστρων (*Philosophumena*, Miller, p. 118), a periphrase clearly intended to designate the sun, and to be read in an ancient hymn cited by Origen, or whoever was the author of the book which bears his name. MACROBIUS (*Saturn.*, i. 22) identifies Atys with the sun: "*Solem Phryges sub nomine Attinis ornant et fistula et virga.*"

³ In the psalms Men, lunar god, is described as the great "measurer."—TRS.

⁴ It is possible that Agdistis may be a local name, as Dindymene, Sipyrene, etc., applied to Cybele, according to the places in which she was worshipped. Pausanias (I. iv. 5) specifies a mountain, Ἄγδος, in Phrygia as the burial-place of Atys. Professor RAMSAY (*Sipylos*, p. 56) recognizes in Ἄγδος the Phrygian word which signified mountain, and which he compares with the Greek ὄχθος, hill; whence Agdistis, "the son of the mountain." It may be asked whether "mountain" was not invented to explain a name which was no longer understood. In other forms of the myth, Agdistis has ceased to be a male god, and appears with all the attributes of Cybele.

⁵ See p. 3, note, of this volume.

⁶ Compare the Greek word σέβειν; Sanscrit, *sabhâdj*, honoured, revered.

which in process of time it wholly superseded.¹ Atys is the form usually used by poets and historians; we also find it as a proper name in Lydia.

The worshippers of Atys, as those of the Syrian Adonis, were in no sense of the word rapt and passive spectators of the rites enacted before them by the officiating priest. To them the oft-recurring drama was a thrilling reality, in which men and women all felt an interest and helped on the unfolding of the cosmic tragedy, during which were depicted the anomalies of terrestrial life, ever failing of its purpose, yet fulfilling it; arrested in its onward progress, yet bounding on with renewed energy. With a potency of which we can form no idea, the assembled multitude grieved for the orb which, pursued by the hurricane, grew wan and pale, and was presently engulfed within black clouds or the greater gloom of night; for the plants that wither under the hot breath of summer, whose foliage turns sere and whose sap ceases to run under the wintry blast. A few months later, the same multitude joyed in the return of light and warmth; it trembled with delight at the reawakening of the god, an event celebrated in a festival that was far away the more important of the two; it lasted six days, and consisted of two parts widely different in their import: a funereal pageant, followed by solemn rejoicings.² In both, the procession moved to the confused sound in turn of funereal chants, tambourines, cymbals, and flutes.³ Branches of pine were carried on the shoulders of the worshippers as a symbol of undying life, a token that the dead they saw before them would rise again.⁴ In this way they reached the grave previously prepared, into which the god was

¹ Greek manuscripts and inscriptions spell the name Ἄτυς, Ἄττυς, Ἄττης, indifferently. Scores of towns in Asia Minor, apparently compounded with the name of the god, have also the double consonant: Ἄτταια, Ἄττια, Ἄττουδα, and the like. The first word of the inscription on the Midas rock (Fig. 1) shows the form ΑΤΕΣ.

² Pindar (Strabo, X. iii. 12) in a dithyrambic exclaims: "O mother of the gods, cymbals, tambourines, and bagpipes have struck up; young yellow pines are lighted in token that the festivity has begun." And in one of the so-called Homeric poems (xiii. 3, 4) Cybele is called "the goddess who loves the shrill-sounding crotals, the flute and loud tambourine." Propertius, xvii. 37; xvii.; MACROBIUS, *Saturnalia*, i. 18.

³ LUCIAN, *Tragodopodagra*, 30-33.

⁴ "Quid pectoribus applaudentes palmas passis cum crinibus galli" (ARNOBIUS, *Adversus gentes*, v. 10).

about to descend. As he was let down, the throng broke forth in wails and sobs, beating their breasts and tearing their hair.¹ In their religious frenzy, some lashed themselves with scourges furnished with bones that tore off great pieces of flesh, and fell a sacrifice to the deity;² others went further and offered their virility, dedicating the rest of their wretched existence to the god who had accepted their self-mutilation.³ Thus each of these festivals swelled the number of eunuch-priests, who on public occasions were wont to lead the chorus of the devotees of Cybele. Under the name of Græco-Galli, they it was who during Persian, notably Roman rule, carried far and wide the rites and practices of the old Asiatic cults (Fig. 4).



FIG. 4.—Archi-Gallus. Capitoline Museum. DURUY, *Hist. des Romains*, tom. ii. p. 528.⁴

the name of Græco-Galli, they it was who during Persian, notably Roman rule, carried far and wide the rites and practices of the old Asiatic cults (Fig. 4).

¹ Μάστιξ ἀστραγαλωτή (PLUTARCH, *Contra Colotes*, xxxiii. 9). Consult also APULEIUS, *Metam.*, viii. 28.

² Suetonius (*Otho*, viii.) writes that as Otho moved against Vitellius, “*die quo cultores deum matris lamentari et plangere incipiunt.*”

³ *Acuto silice* (Catul., xliii. 5); *rupta testa* (Juvenal, vi. 514). We find here, too, the sacredness of stone, in connection with the idea of sacrifice, as against metal (*Hist. of Art*, tom. iv. p. 373). It will be seen that the epithet *semi viri*, applied to the priests of Cybele by the Romans, was well deserved. With Italian brevity, the day of flagellations and self-mutilation was indicated in the calendar by a single but pithy word, “Sanguem.” Julian’s account of the “mysteries of the mother of the gods” (p. 168) coincides with the calendar, except that he omits to mention the two last days, *i.e.* Requies and Lavatio.

⁴ The effeminate character of the eunuch-priest will be observed. From his ears depend heavy earrings; a diadem surrounds his brow, formed by three large coins that serve to keep in place the head-tire, which falls in rich folds behind his back. Long rows of pearls on either side of the face reach to his middle, where they rest in the horizontal folds of the shawl, and in a basket brimful of fruit, which he

The pageant attending the resurrection was in brilliant contrast with that which had preceded it. Branches of pine re-appeared amidst the acclamations and the tumults of joy of the multitude, whose delight at the return of the god was translated by gambols and running about.¹ The music was in harmony with the new mood. It had been grave, sad, and slow before; now the clapping of hands, the dancing, capering, singing, and striking of brazen shields to mark the time, could scarcely keep pace with its phrenetic, bewildering movements.² In order to keep up or renew their flagging spirits, they had recourse to copious libations, until, overcome with fatigue and exhaustion, they one by one fell by the roadside, among the woodlands and vales whither they had wandered. The fifth day was given up to rest, so as to enable them to get over the effect of their violent emotions, and prepare them to return to the routine of daily life. The *lavatio*, or bath, occurred on the sixth and last day of the performance, when the puppet-god was carried to a clear running stream, stripped of its gay bridal apparel, and plunged into the water, even as a bride on the eve of her marriage.³

The favour enjoyed by Asiatic rituals away from their original

supports with his sinister hand; the dexter holding up an olive branch covered with berries. A thick golden chain goes twice round his neck, and from it hangs a golden shrine of Atys, whose image, crowned with the Phrygian tiara, is distinctly seen. Against the wall is a colonnette topped by a bearded bust, perhaps of the same Atys before his self-mutilation, or Zeus-Pater together with a scourge, flute, tambourine, and the mystic cystus.

¹ The solemnity of Cybele was opened with the Dendrophory, or carrying the pine to the temple—the *arbor intrat* of the calendar. With regard to the sacred tree, the fillets always surrounding it, as well as the place it occupied in these mysteries, see ARNOBIUS, *Adversus gentes*, v. 16; and ZOGA, *Bassi rilievi antichi di Roma*, tom. i. Plates XIII., XIV.

² LUCRETIUS, *De natura rerum*, ii. 621; APOLLONIUS, *Argonautica*, i. 1135–1139.

³ The erection of the famous temple of Cybele and Atys at Pessinus was ascribed to Midas (Diodorus, iii. 58). In obedience to the injunctions of the Sibylline books, the Romans removed, by order of the Senate, the statue, *bætylus*, of the goddess to their city, where the rites connected with her mysteries seemed to have followed her. The Italians were particularly careful in washing every year, on the 6th of the calendar of April, her shrine in the waters of the Alno, a rivulet which falls into the Tiber close to Rome. This was in imitation of the ceremony which was yearly enacted at Pessinus, on the banks of the Gallus, a stream which flows through the town, where the *lavatio* could be performed, before it joins the Sangarius. It is evidently in allusion to this rite that Herodotus says, “The Phrygians used to celebrate the orgies of the river Gallus, a torrent which flows through the town of Pessinus” (*Hist.*, i. 35).

homes, the fascination they exercised over the civilized nations of the old world, are our justification for dwelling, in this place, upon the customs and the religion of a people which has left no images of its gods or heroes. Types which may be traced back to Phrygia and Lydia will be found in the sequel of these studies. Such would be Cybele, her head surmounted by a tall turreted crown, now enthroned, a lion at her side (Fig. 5), now driven in a chariot or riding the king of feræ (Fig. 6), along with a long list of gods and heroes—Menes, Atyses, Midases, and Marsyases, whose nationality is rendered unmistakable by the Phrygian cap and the trailing brodered robe. To these may be added the Amazons, whose noble type so often figures on ancient Greek vases, where they preserve the characteristics of their national costume. The orgies of Dionysius offered stupendous opportunities to the Greek artist for his portraiture of the human figure in all its varying outline. Under his touch it became a living, pulsating reality, the like of which had never been seen or attempted before; whether in the endless variety of fold of the disordered dress and dishevelled hair, caught up by the breeze, flying far behind, helping not a little the movement of the scene, or the audacious attitudes of the worshippers, men and women, whose conflicting passions, caused by wine and religious frenzy, struggled on to the surface, and were reflected in their whole being. If the name of the deity in whose honour festive bands moved on Mount Cithæron is different from that with which the sanctuaries of Asia Minor have made us familiar, the oldest examples of orgies are those of Cybele and Atys; during which nervous excitement trenched on those curious pathological phenomena designated in a general way as hysteria, and which in our day have received the careful attention of the medical profession. Our practical everyday life has nothing which resembles the tumult and rebellion of the senses, the periodical fits of madness, which seized the followers of Cybele during the performance of what may be termed their



FIG. 5.—Cybele seated on throne. Reverse of bronze coin. Cadi, Phrygia. DURUY, *Hist. des Romains*, tom. i. p. 534.



FIG. 6.—Cybele seated on a lion. Reverse of bronze medallion of the Empress Sabina, wife of Hadrian. DURUY, *Hist. des Romains*, tom. i. p. 524.

sacred carnival ; deep gorges and forest gloom being the stage on which it was enacted.

We have taken advantage of the opportunity which offered itself here for giving some idea of these strange scenes, so as not to be obliged to refer to them again later on, when we meet on our path a whole series of works inspired by the Bacchanalia. The Greeks, it should be remembered, in the palmiest days of their political and artistic existence, never lost their taste for the gross pleasures afforded by the orgies, nor the tradition of their origin ; for in their wildest transports they invoked, as occasion served, the Phrygian Cybele or the Thracian Dionysius. That which strictly belongs to Greek genius is to have been the first to feel, or at least to render, the beauty of the human form, as it revealed itself in the agitation and abandonment of the dance ; its lines, as those of the drapery, changing with each step ; the latter now clinging to the body, now filled with the breeze and carried over the shoulders of the dancers.



CHAPTER II.

PHRYGIAN ART.

SIPYLUS AND ITS MONUMENTS.

THE Sipylus forms a short range of mountains on the north of the Gulf of Smyrna, about ten leagues from east to west, by three or four broad. It naturally divides itself into three parts: the Iamanlar-Dagh, to the west, is but 976 m. high; the Manissa-Dagh, to the east, reaches 1500 m.; whilst the Sabanja-Dagh holds a middle course, and serves as intermediary between the other two¹ (Fig. 7). Each section has characteristic features of its own, engendered by difference of geological formation. Thus the western district, from the river Bournabat to Menemen, is a trachytic rock, with beautiful patches of red, black, and blue; but the eastern, which is far the most imposing, belongs to the secondary system, or the period intervening between eruptive and sedimentary formations. It rises high and formidable on the north and east sides, forming almost perpendicular walls, intersected by grottoes and gigantic faults, which seem to run right through the hill, with cones and hillocks towards the south of great beauty of form and colour, yellow, red, and brown. The

¹ Our description of the Sipylus and its monuments is derived from the following sources, to which we refer the reader who should wish to obtain ampler information:—TÉXIER, *Description de l'Asie Mineure*, tom. ii. pp. 249–259; Plates CXXIX. — CXXXI. bis; HAMILTON, *Researches in Asia Minor*, tom. i. ch. iv.; A. CHERBULIEZ, *La ville de Smyrne et son orateur Aristide*, 4to, 1863 et 1865 (*Extrait des Mémoires de l'Institut national genevois*); CURTIUS, *Beiträge zur Geschichte und Topographien Kleinasiens* (*Abhandlungen* of the Berlin Academy, 1872, notably chapter headed “Alt Smyrna,” with Plates IV. and VI.); WEBER, *Le Sipylos et ses monuments*, 8vo, 1880 (Paris, Ducher); KARL HEUMANN, *Ein Ausflug in den Sipylos* (WESTERMANN, *Illust. Deutschen Monatsheften*, Juli, 1885, Brunswick), 8vo; W. M. RAMSAY, *Newly discovered Sites near Smyrna* (*Journal of Hellenic Studies*, tom. i. pp. 63–74); *Studies in Asia Minor*, 2, *Sipylos and Cybele* (*Journ.*, tom. iii.).

Iamanlar-Dagh lacks boldness of outline, afforded by precipitous cliffs and steep ravines ; but from its long fretted line of crest, innumerable spurs run out towards the south, west, and east in curious fan-like fashion, seeming to invite the pedestrian to ascend their gentle declivity (Fig. 8). The summits may be stony and bare ; but the slopes have enough vegetable soil, notably in the ravines, where the moisture drained from the mountains

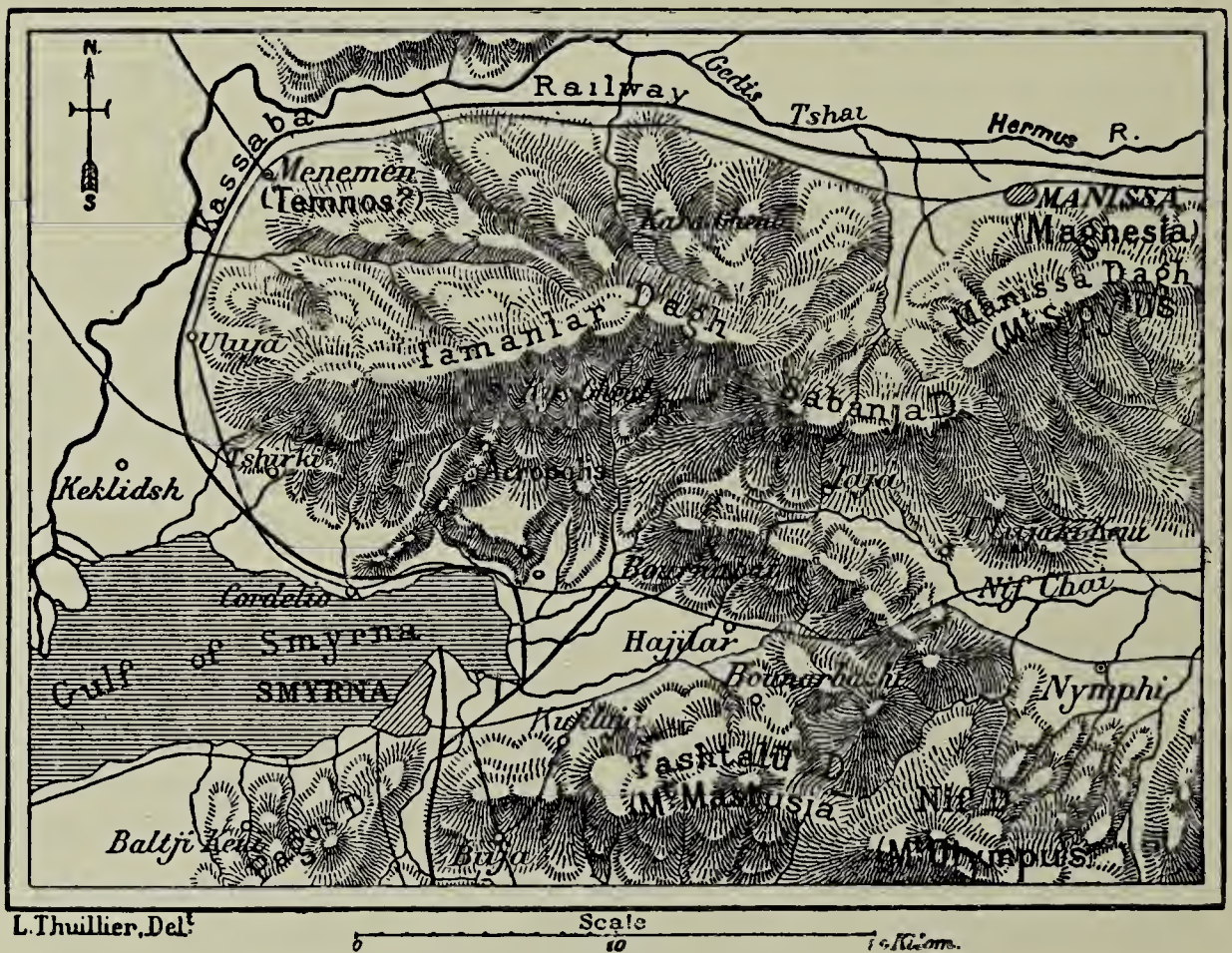

FIG. 7.—Map of Sipylos. CURTIUS, *Beiträge*, Plate IV.

lasts for many a month, to enable the farmer to grow corn, vines, olive, and other fruit-bearing trees.

The western side, therefore, was marked out by nature to shelter from the earliest days a compact group, brought thither by proximity of a clement, unruffled sea, and a soil naturally productive. Consequently, here and here alone can we expect to find traces of a long settlement, with all that the term implies. The oldest structures must of necessity occur on the summit ; but, as the conditions of life improved, they would gradually spread down the slopes on to the flat level around Bournabat, where the primitive tribe finally settled.

Its passage, however, has been obliterated by countless generations that have succeeded each other and contended for this rich, loamy piece of ground. Here, on the old road skirting the river Hermus, rose Magnesia, now Manissa, which, though much shrunk from its former size, has not ceased to be a bustling place, teeming with life and activity. On the other hand, the narrow ravines and precipitous sides of the Manissa - Dagh afford very insufficient space for figures, tombs, or temporary refuges, of course scooped out of the solid rock.

Attention was forcibly drawn to this district in early days, both on account of the advantages it offered by land and sea, and the remains which connected it with a remarkable past. Pausanias, a native of this neighbourhood, writes of it as the seat of the Pelopidæ. "Our country," he says, "affords many proofs of the reign of Tantalus and Pelops, proofs that are extant to this day; to wit, the lake and the tomb of Tantalus, the throne of



FIG. 8.—The Iamanlar Dagh. Seen from the quay of Smyrna. WEBER, *Le Sipylus*.

Pelops on the summit of Sipylus,¹ above the Hieron of Mother Plastene" (v. 13). A little further on, he speaks of "the oldest known statue of the Mother of the Gods, to be seen in the district of Magnesia,² and of the rock that looked for all the world like

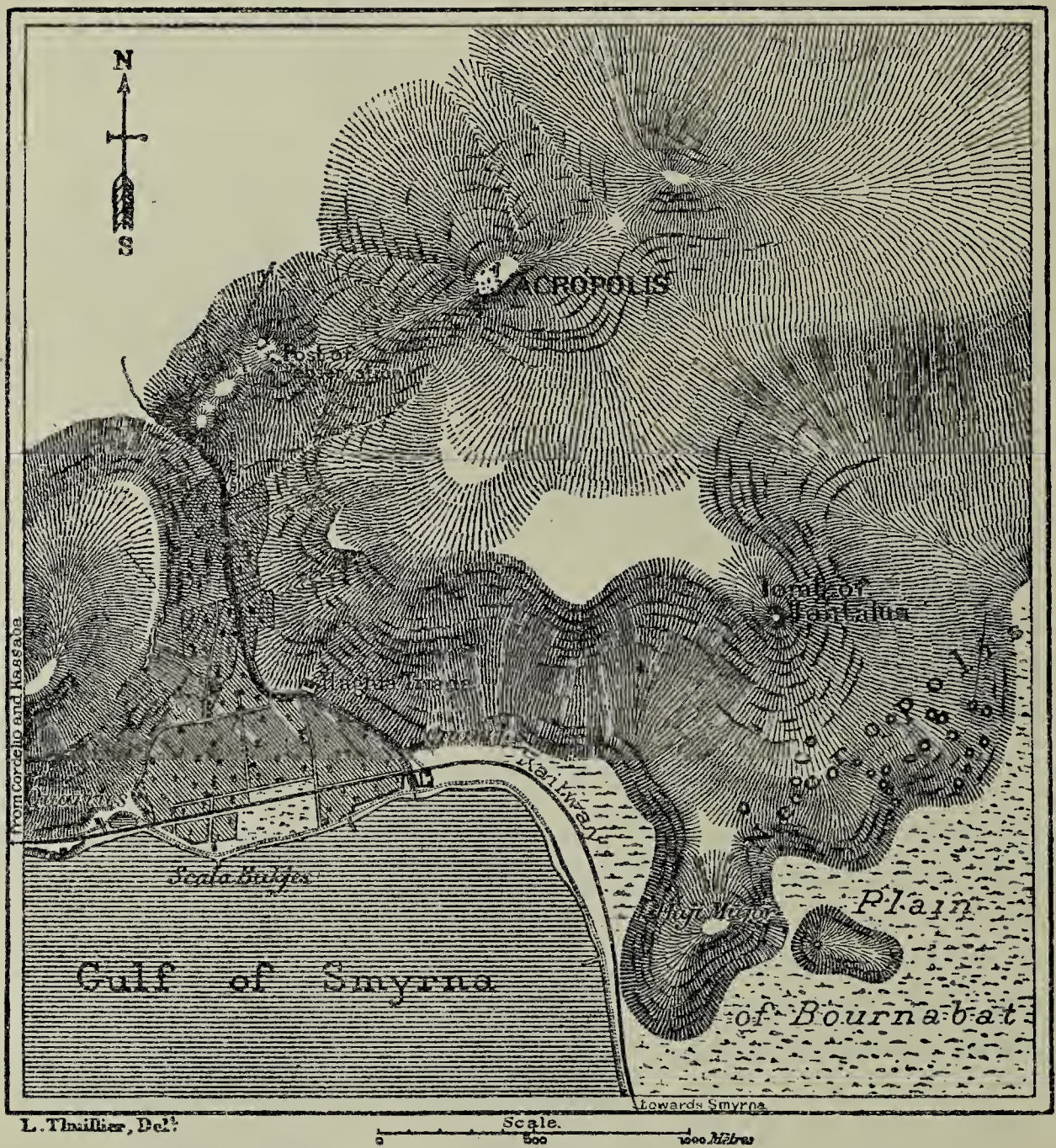

FIG. 9.—Topographical sketch of site north-west of Bournabat. CURTIUS, *Beiträge*, Plate IV.

a woman immersed in grief," which popular fancy identified with Niobe.³

¹ Weber translates Ταντάλου λίμνη by Tantaleis Harbour; but λίμνη is not synonymous with λιμνή, and, unless we suppose an error in the manuscripts, it must apply to one of the small lakes, the Kiz Gheul, or more probably still the Kara Gheul, actually found in the Iamanlar-Dagh (see Fig. 8).

² *Ibid.*, iii. 22.

³ *Ibid.*, i. 21.

The monuments may be divided into two distinct groups, corresponding with the sharply defined regions east and west of Sipylus. Aided by the excellent map drawn for us by M. Hirschfeld (Fig. 9), we will begin with the remains on the Iamanlar-Dagh, specified by Pausanias, leaving for the last the statue of Cybele on Mount Codine, and the curious rock which recalled the pathetic legend of Niobe, situate on the eastern side.

The site of the Iamanlar-Dagh group is fixed by the Tantaleis tomb. With this should be ranged other vestiges in the immediate

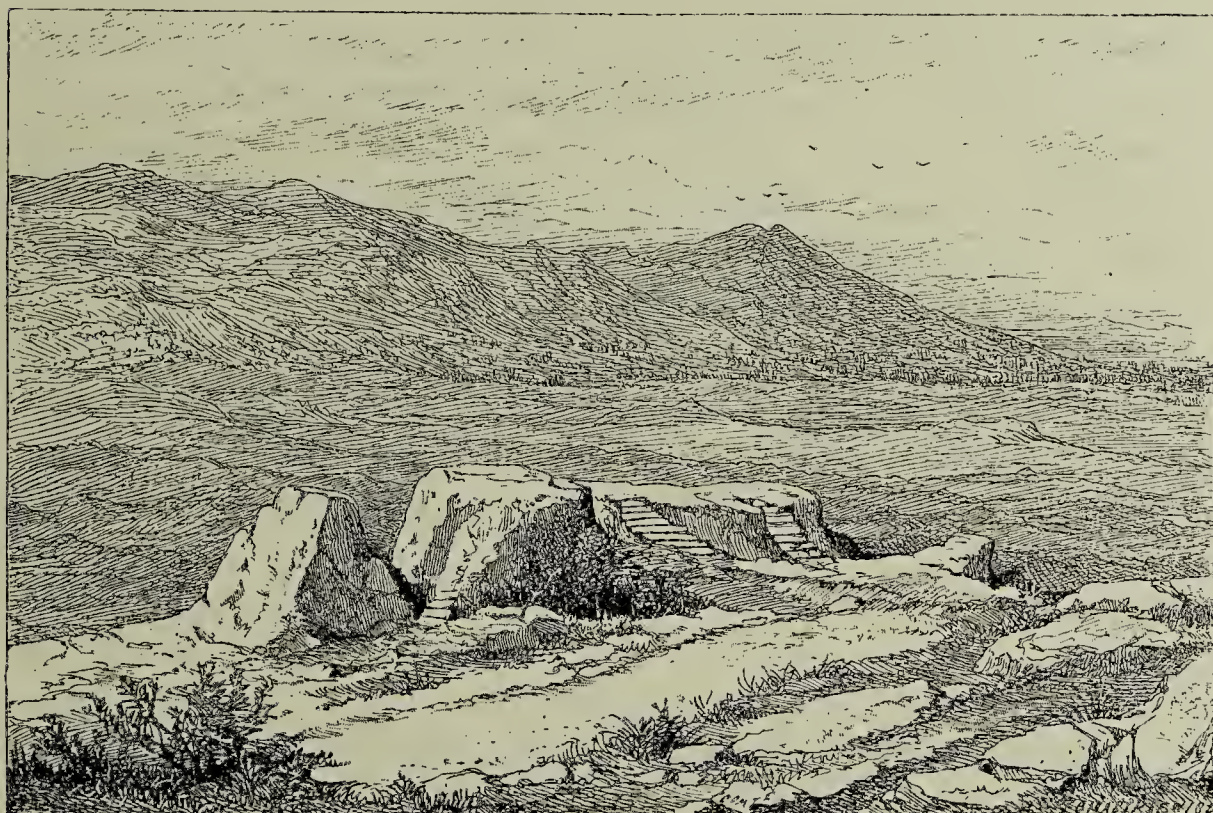

FIG. 10.—Post of observation on Sipylus. CURTIUS, *Beiträge*, Plate VI.

neighbourhood, bearing unquestionable marks of antiquity. The creek or primitive harbour, now covered by the alluvial plain around Bournabat, from which it takes its name, is found on the north of Smyrna. Facing the modern town of Haji Mūjor (Fig. 9) is an isolated hillock, which in former days was an island at the entrance of the harbour, and served to render its waters "as smooth as oil." If one ascends the undulating ground which, on the north, looks down upon the ancient haven, a necropolis, whose graves are all tumuli, is first met with, and a little higher up is the Acropolis, along with other structures cut in the solid rock, with general direction to west. These remains consist of

terraces levelled out on the summit of a massive rock 15 m. long, but the use of which is not easy to make out.

Some think that the site, commanding as it does the plain of Bournabat and the Bay of Smyrna, was used as a vedette (Fig. 10)—a supposition which would account for the steps leading to the esplanades, but would shed no light on the excavation, 2 m. long, cut in the centre of one of these open floors. Was this a grave or a trench, in which a man could lie unperceived as he scanned the surrounding country? Be this as it may, the fact that a fortress, numerous graves, stairways, platforms, and the like are crowded in a narrow space, leads to the conclusion that this was the site of the old city, by many centuries the senior of Greek Smyrna. Then, too, fragments of Cyclopæan walls, some running from north to south, intersected by others so as to form irregular enclosures, meet the eye along the whole side of the hill. Others, again, are barely visible above ground, and might be taken for walls built by the farmers to keep the earth in position, or pen their animals,¹ but for the distinct testimony of T  xier (who made a thorough study of the site and of all the monuments) to the effect that, although in places the stones are of varying size, they are so deftly fitted together as to produce a level surface, so that one is sorely tempted to make them coeval with the Acropolis and the neighbouring tombs. This elevated spot, with outlook towards the valleys of Smyrna and the Nif Chai, was the first to be inhabited; but the settlers do not seem to have been a seafaring or colonizing race, but to have chiefly relied on the natural productiveness of the soil and inland traffic.

The Acropolis, which forms the culminating point of these various remains, occupied a secondary summit 350 m. high—some 1250 m., as a bird flies, from the sea below. Half an hour's walk takes you to it, but the last part is a stiff bit of climbing. The south side is almost perpendicular, and its approach on the west is rendered difficult by quarries, whence was obtained the material for the erection of the rampart (Fig. 11). The hill, of which the summit forms an elongated plateau, measured lengthwise, is barely 45 m.

¹ T  XIER (*Description*, tom. ii. pp. 255, 258) thinks that this was a long wall of enclosure, which served to connect the necropolis, together with public and private buildings, with the fortress. On the other hand, HAMILTON (*Researches*, p. 49) and G. HIRSCHFELD (*Alt Smyrna*) believe that all these walls are modern; whilst WEBER (*La Sipylos*) would divide them into two sets, ancient and modern.

by 30 m. broad. It is divided in two parts: an outer court to the east, and an inner, fenced on the north, south, and west sides, c, d, by a double rampart, particularly noticeable on the north and east. Of wall g fragments alone exist, yet they suffice to show that it was parallel to c, d. The Acropolis was protected on the south by the natural escarp of the rock, to which additional strength was given by a wall wholly disappeared. Towards the east, where the hillock rises above the level of the plateau, are flat shelves with small oblong grooves, evidently made to receive the foundation stones of the outer wall. On the north side the gentle declivity of the hill made it necessary to resort to precautionary measures. These are found in a supporting wall which skirted the road, running along a narrow ridge up to a gateway about four feet wide, which it entered at right angles, and a square tower in front of it.

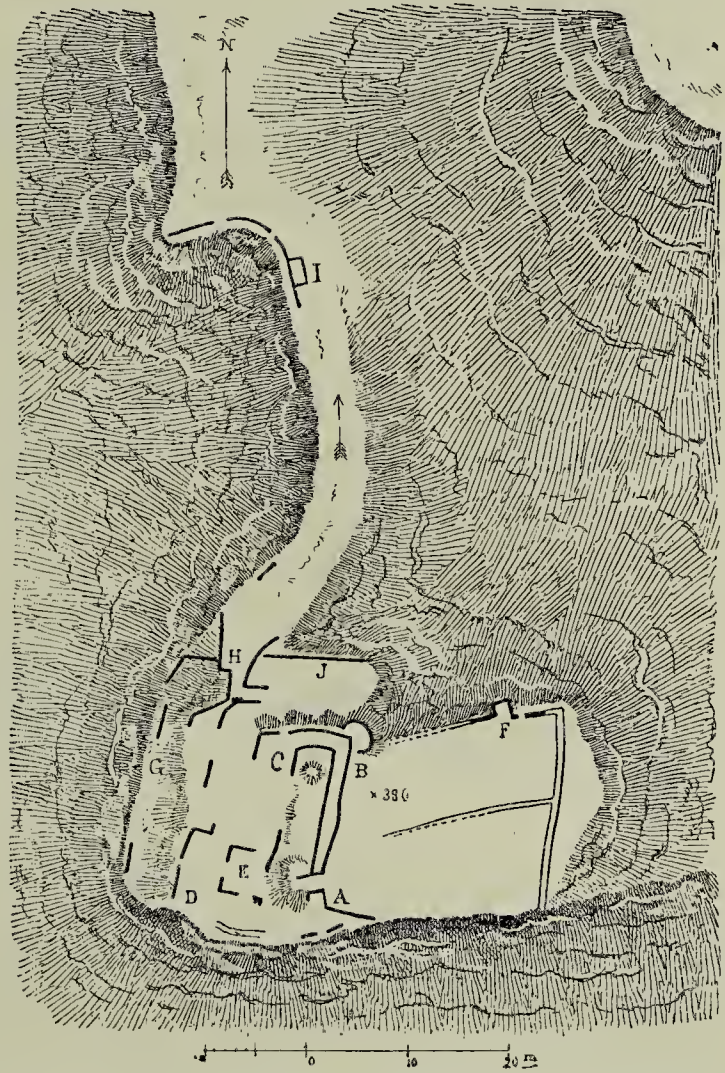

FIG. 11.—Acropolis of Iamanlar Dag. Plan. WEBER, *Le Sipylus*, Plate I.

The approach to the Acropolis on the west was defended by ramparts scooped out of the projecting rock, which so narrowed the path as to allow only room for a man at a time (H). A huge excavation or ditch, hollowed in the rock on the left side of the path, whose wall below the escarp was almost perpendicular, is still seen (J). The ditch was covered by an outer wall on the left; a second (c, B, in plan), far the best constructed and the best preserved, crowned the talus (Fig. 12).

The constructive scheme of the area wall shows that it was the work of one architect, although it exhibits stones with vertical

joints carefully squared at c, polygonal at B, with horizontal courses and oblique joints at o; thus yielding another instance of the danger of dating ancient structures from a small portion only. Builders in early days placed their materials exactly as they came from the quarry, without troubling themselves as to the effect they would ultimately produce. Blocks cut of the required shape, which should harmonize with a given style, were a late development.

It remains to notice two curious details. A ditch, approached by steps, enabled the defenders to take refuge in it when assaulted and obliged to withdraw into the fortress. The north-east angle of the external wall (B, Fig. 11), facing the ditch, was strengthened by a retaining semicircular wall, four courses of which still exist, and at a distance look like an unfinished tower. A quadrangular salience will be observed in the north face of the rampart which surrounds the eastern court (F, Fig. 11). This is divided into two equal sections by a partition of polygonal masonry, akin to the Acropolis properly

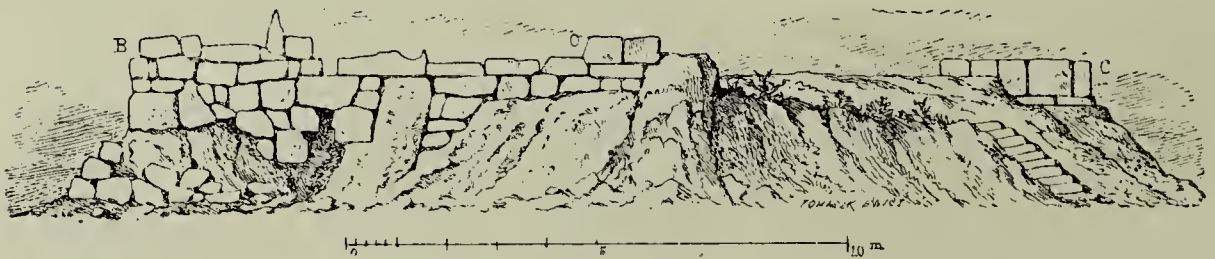

FIG. 12.—Northern wall of the Acropolis, seen from the outside. WEBER, Plate I.

so called, save that the stones are smaller. The western court was a veritable redoubt, and numerous traces and fragments of walls bear witness to the effort of the builder to render it as strong as possible and capable of resisting sudden attacks from without. A hole towards the north-east corner, with rubbish lying in a circle, probably covers the site of an ancient cistern. The spade alone would reveal its true character, as also the real use of the walls at E, built of stones carefully dressed, forming a central square in the redoubt, measuring six or eight metres each way.

By no means the least interesting item of this Acropolis is the gateway (A, Fig. 11), with sides sloping upwards, giving it the appearance of a truncated arch (Fig. 13). It is closed at the top by two massive lintels of equal length, placed one behind the other. The exterior slab measures two metres by seventy-four centimetres, whilst the inner is ninety centimetres in height. It gave access

to a slanting passage, at the end of which was probably a flight of steps leading to the esplanade, but now buried under stones that have fallen in. The roofing of the passage consisted of huge slabs.

We have already directed attention to the regularity of the material about the gateway, notably on the left side. It is self-evident that the unequal size of the blocks determined its having two courses on the dexter hand and three on the sinister. Here and there the lines are broken, even crooked; nevertheless there is a decided tendency towards horizontal courses. The subserviency of the builder to the stonecutter is marked throughout.

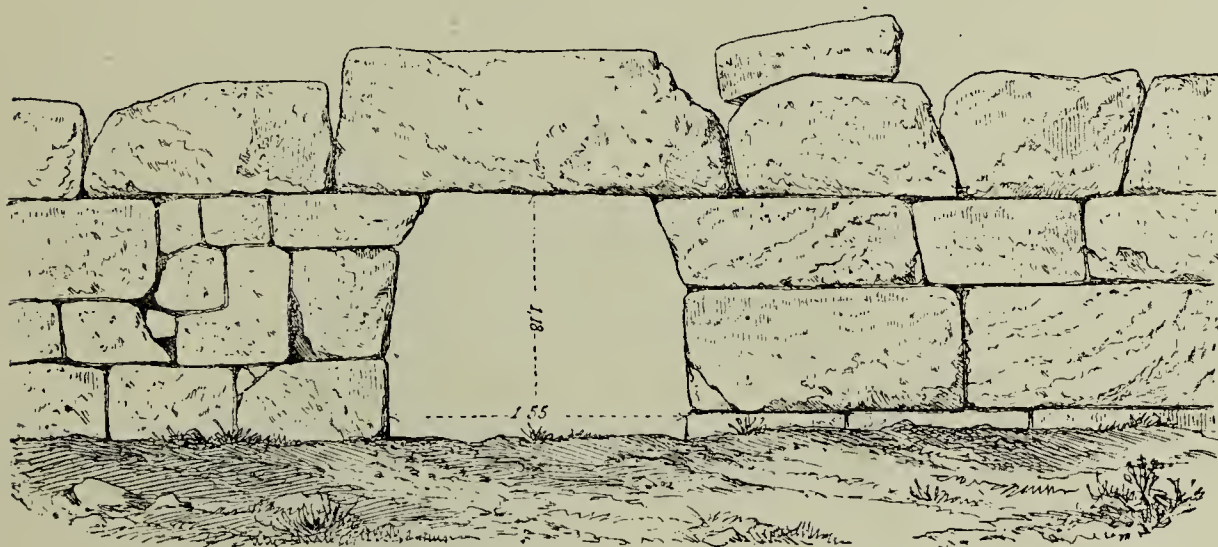

FIG. 13.—Gate to Acropolis. WEBER, Plate I.

The principal eminence was selected as the site of the Acropolis, for the double purpose of making its defence an easy matter and allowing of efficient vigilance being exercised over the whole surrounding country. The necropolis was not exposed to the same risks, and could conveniently be placed on a lower grade, namely, the rocky slopes which descend towards the plain of Bournabat and overhang the ancient harbour (Fig. 9). The tumuli are about forty-five in number, and exhibit constructive skill enough. They are all stone-built and on the same pattern—a conical mass reposing on a circular substructure, itself in touch with the living rock.

Down to 1835, the more imposing, commonly called the Tantaleis tomb, could be descried from the quay; in that year it was explored by T exier and a number of sailors placed at his disposal by the French admiral, Massieu de Clerval, stationed at Smyrna

(Fig. 14). The roof had already fallen in, but the sides were intact, and their present state is due to shafts sunk in the centre of the mass by T  xier. Before doing so, however, he had the tumulus carefully measured. The annexed woodcuts, as well as T  xier's verbal description, will enable the reader to grasp its inner arrangements.¹ Its diameter is 33 m. 60 c., or 105 m. 537 c. round. It forms a perfect circle, and is wholly built of small stones, laid out without mortar (Fig. 15). The centre is occupied by a rectangular chamber 3 m. 55 c. by 2 m. 17 c., and 2 m. 86 c. in

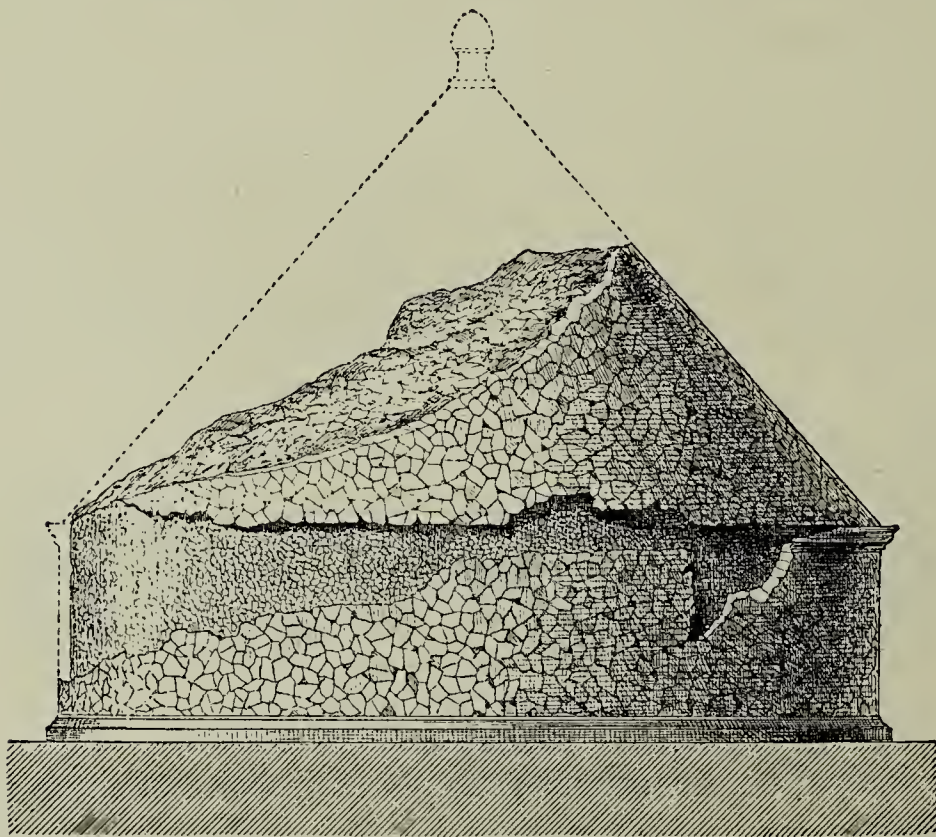

FIG. 14.—View of tomb of Tantalus before the excavations. T  XIER, *Description*, Plate CXXX.

height under the centre of the arch (Fig. 16). The courses are horizontal throughout, and on average from 55 c. to 20 c. high. The vaulted appearance of the chamber is due to the corbel arrangement of the masonry; but there is no true arch, and, as a natural consequence, there is no key, the vacant space at the top being closed by a huge stone set on the last two courses (Fig. 17).² The mortuary chamber had no passage, and was

¹ T  XIER, *Description de l'Asie Mineure*, tom. ii. pp. 253, 254. We have used WEBER'S *Sipylos*, pp. 19, 20, to check T  xier's narrative.

² Fig. 17 is after Weber, *loc. cit.*, Plate I. He was the first to notice that the curve formed by the ogee begins from the base of the chamber, and not, as stated

walled up after the body had been laid in it. The space around, measuring 3 m. 50 c., was tightly packed with stones of different

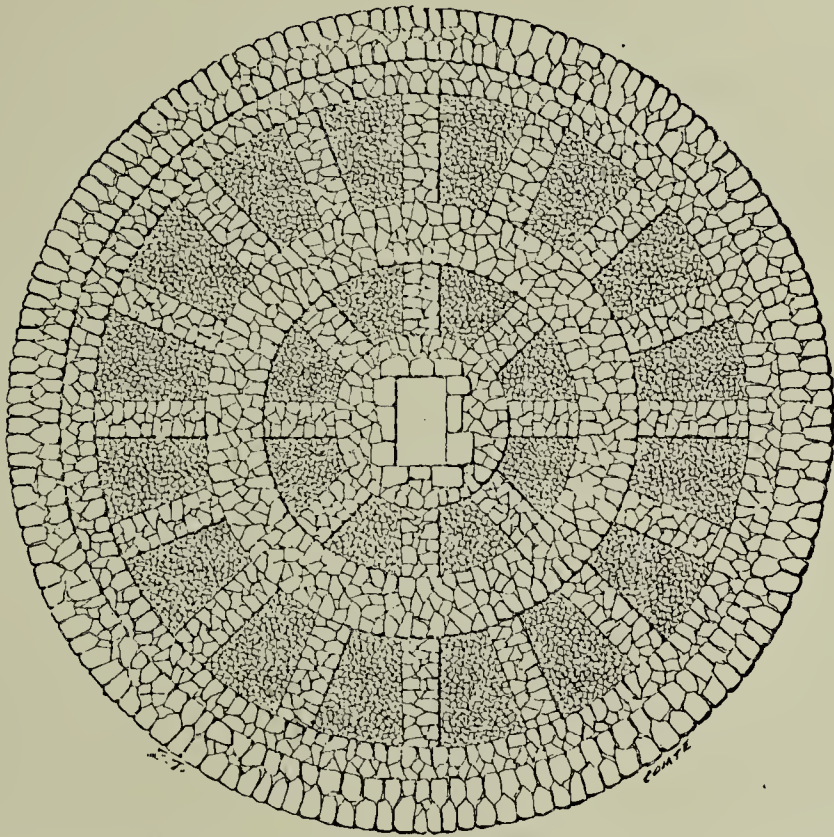

FIG. 15.—Plan of tomb of Tantalus. TÉXIER, *Description*, Plate CXXX.

sizes so as to fill up every interstice ; eight partitions, 2 m. 70 c. long

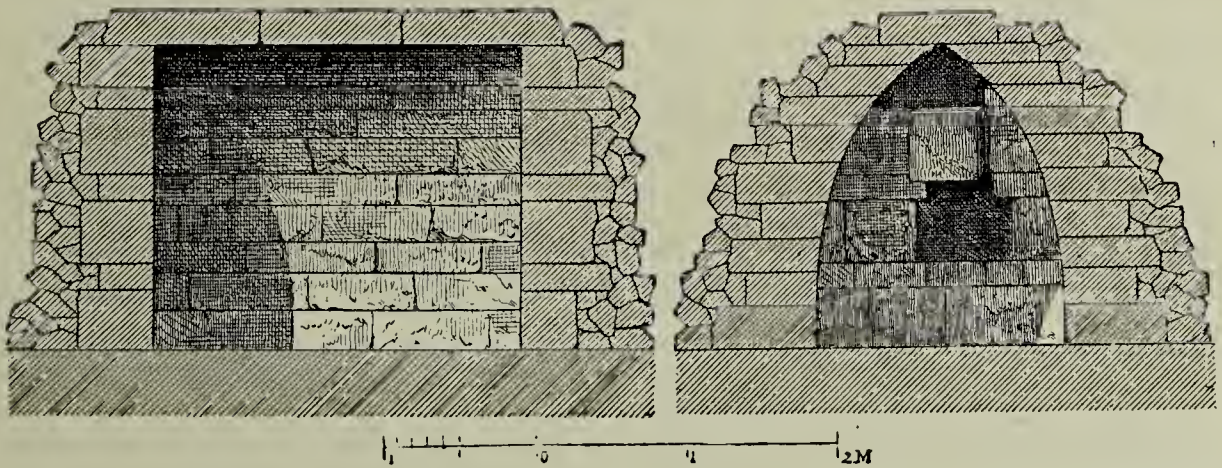

FIG. 16.—Chamber of tomb of Tantalus, Longitudinal section. TÉXIER, *Description*, Plate CXXXI.

FIG. 17.—Chamber of tomb of Tantalus. Transverse section. WEBER, *Le Sipylos*, Plate I.

and three stones deep, ran from the central nucleus to a first by Téxier, from the third course. As to the hollows which appear towards the top and the middle of the wall, they are due to attempts doubtless made with a view to ascertain the existence of some secret passage to the grave-chamber ere it was closed up. Similar attempts proved vain, for nothing has been revealed save a stony mass.

circular wall, whence started other sixteen, which extended to the external wall, 3 m. 70 c. thick. The depth of this wall was not constant; thus the upper part was built of large stones and 2 m. 36 c. thick, whilst the lower was but 1 m. 50 c. To bring it to about the same strength, therefore, an internal and external casing was added. Outwardly, it was quite plain, the only attempt at decoration being a stylobate which rests on a rude plinth, the substructure of the tumulus, and a cornice of feeble salience.

It would be hard to conceive a better-devised construction, so as to enable it to withstand the action of the weather for many centuries. The intervening spaces between the partition walls are filled in with pebbles, closely packed and admirably put together, though without cement. Thanks to its solidity, the structure must have been preserved in good condition down to the last days of antiquity, protected as it was by the memories and traditions which attached to it. It was a striking object in the landscape—the first to greet the mariner on his return, the last to remind him of the home he left behind; bequeathed, too, said tradition, by revered ancestors, and one “that could not be buried out of sight”—*οὐκ ἀφάνης*, as Pausanias has it. Everything seems to indicate that the tumulus under notice is the Tantaleis tomb. When T  xier began his labours part of the roof was standing; given the diameter and the direction of the slope, the whole height, which he computes at 27 or 28 m., could be easily ascertained. The only data which present some uncertainty are the dimensions of the finial. This ornament has not been found, though it is not difficult to divine its nature. Around many other tumuli in the necropolis, whose decorative scheme and arrangement proclaim them coeval with the Tantaleis tomb, quite a large number of phalli of red trachyte have been discovered half embedded in the ground. In size they average from 40 c. to 1 m. 40 c. Primitive symbols of life and immortality, such phallic emblems, when introduced as finials, had exactly the same value as the rosette in Greek buildings. It is self-evident that the bases of all these phalli were intended to fit some cavity where they would not be seen, for they were left rough. Curiously

¹ It is curious that T  xier, who dug his way into the tumulus, should not have stated in what condition he found the grave-chamber. Did he pick up antique fragments? If so, he has kept the secret to himself.

enough, holes of corresponding size appear on the apex of the tumuli. The phallus is not uniform in shape—far from it—but evinces great variety. Among the more advanced forms are globular caps, with listel supported on stems (Fig. 18); elsewhere we find the usual conical ending (Fig. 19), and some few exemplars are mere cylinders with central swelling.¹

The Tantaleis tomb, as the larger and more important of the group, rises at the top of a hill somewhat apart from the others by which it is surrounded, as a monarch by

his subjects. These are closely packed together, connected sometimes by a wall, and one was found with two chambers. Being more lightly built than the larger tumulus, their state is even more ruinous, and treasure-seekers found less difficulty in bringing about their demolition. All have been opened from the roof or the sides, and in many instances nothing remains to

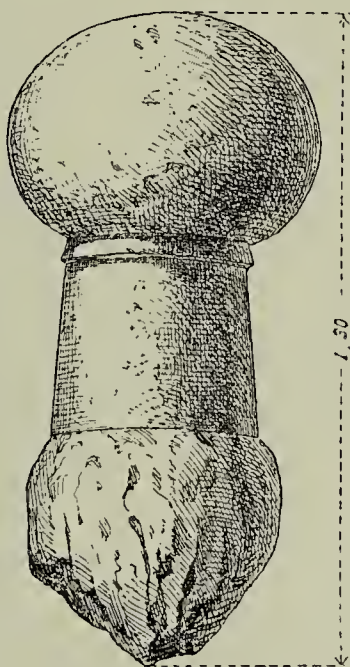

FIG. 18.—Terminal phallus.
WEBER, *Le Sipylos*, Plate II.

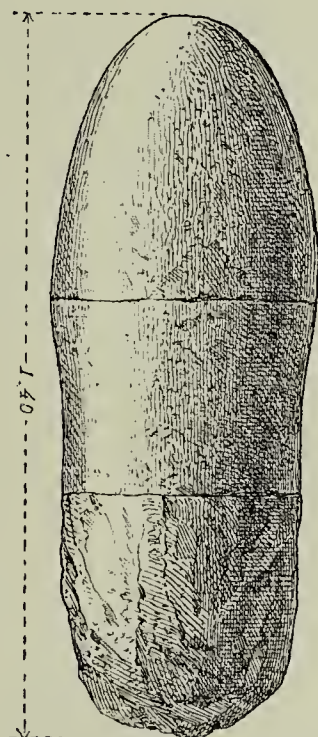

FIG. 19.—Terminal phallus.
WEBER, *Ibid.*, Plate II.

mark the site but a heap of earth and rubbish. With the exception of these the plan can always be made out. Sometimes it is very similar to that of the Tantaleis sepulchre, doubtless built for a king, and as such must have been taken as pattern. The mortuary chamber has been walled up after the entombment, and a stone-work, set without mortar, made around it. It is intersected by partitions of channelled masonry, which, starting from the grave, extend to the exterior wall (Fig. 20). The

¹ About half a mile eastward of the colossal Cybele are tombs, and hard by Professor Sayce noticed between two triangular niches an immense phallus figured on the rocky wall (*Hell. Studies*, tom. i. p. 90).

The learned professor observes that the phallus in question is a stalagmitic formation.—TRS.

only difference is this: that as the tumulus is much smaller, multitudinous concentric circles were not required; hence from each

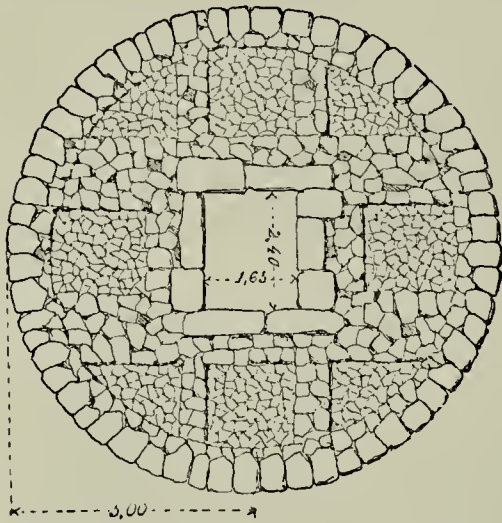

FIG. 20.—Tumulus of dry stones. TÉXIER, *Description*, Plate CXXXI.

angle of the central block, which is square, stone divisions of channelled masonry ran parallel one to the other, until they met the outside wall. There is yet a simpler type (Fig. 21), interesting from the fact that the flat arched chamber could be entered at all times by a broad passage covered with stone flags.

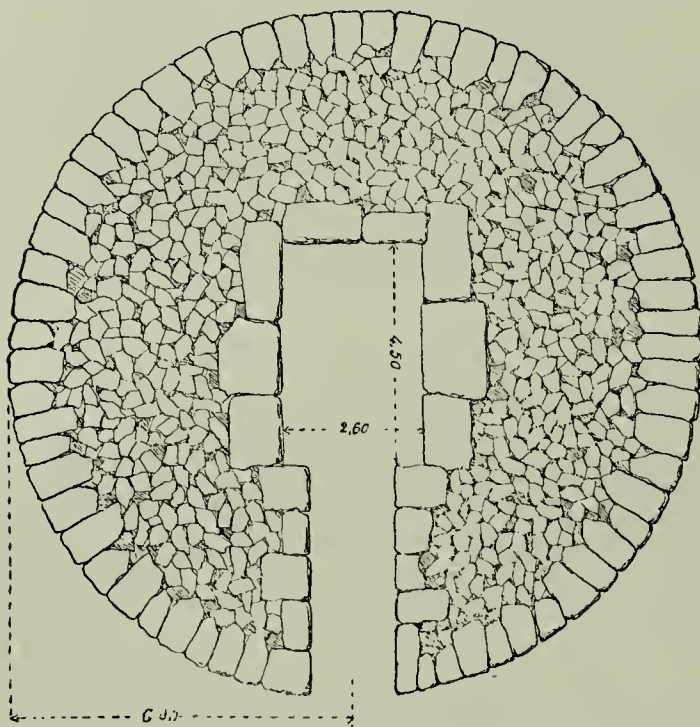

FIG. 21.—Tumulus of dry stones. TÉXIER, *Description*, Plate CXXXI.

It had no divisionary supports; a rude masonry of uncemented stones of average size extended from the central block to the circular wall. Large blocks were reserved for the substructure and the inner casing. Despite these drawbacks, it had enough solidity for its purpose. In the floor of some of these tombs, which is one with the living rock, a trough has been excavated for receiving the body. Around it may still be seen a shallow groove, which fitted the covering slab or stones. The orientation of the tombs is not constant, and, in each case, seems to have been determined by the hypsometric lines of the mountain. The Tantaleis memorial points north-east and south-east at an angle of sixty degrees.

Remains of another important monument should

be classed along with the Sipylus group, whose mode of execution, in part structural and in part rock-cut, they reproduce. We may consider the exemplar, therefore, as likewise the work of the people who placed their tombs betwixt the harbour and the fortress. The

bold hillock which bears these ruins is further inland and on a lower plane than the Acropolis, on a line with the village of Petrota, towards the head of the valley washed by a stream, supposed to be the Acheleos. Its truncated summit, with vertical sides, forms a striking feature in the landscape which it commands; and to this circumstance it probably owes its modern name of Ada, "island."¹



FIG. 22.—Plan of Sanctuary in the Iamanlar Dag. WEBER, *Le Sipylus*, Plate III.

It is a plateau more or less level, 70 m. by 20 m., which divides itself into three distinct parts (Fig. 22): a square, massive rock to the north, with precipitous sides 4 m. high (N in plan); an esplanade on a lower level with a circular hole in the middle, resembling the mouth of a cistern or well (R); and, by far the most remarkable feature, a gigantic rock, 22 m. by 13 m. broad, which forms the southern extremity of the ridge (M). A deep chasm, 8 m. long

¹ RAMSAY, *Newly discovered Sites*, p. 68.

by 4 m. wide and 4 m. deep, appears at the north-east angle (A in plan, Fig. 23). The bottom of this excavation is occupied by a kind of chamber open to the sky, 5 m. by 2 m. 20 c. (Fig. 24). The main walls are connected with one end of the grave-chamber by a

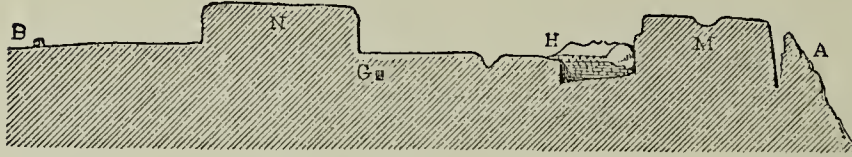

FIG. 23.—Sanctuary. Section through A B. WEBER, *Le Sipylos*, Plate III.

thin circular wall; at the other they disappear under rubble and large blocks (*d*) which have rolled down

into the excavation. The courses which form the walls of this chamber are very regular (Fig. 25); they are 36 c. high, and the length of the units varies between 39 and 72 c. Around it, distant 1 m., runs a polygonal wall which closed the entrance towards the north (Fig. 24, *c*, *b*), and protected the east side where the rock is not very high (H).

The esteem in which the monument was regarded may be gathered from the works of art surrounding it. As far as the configuration of the ground permits, which to the south and west

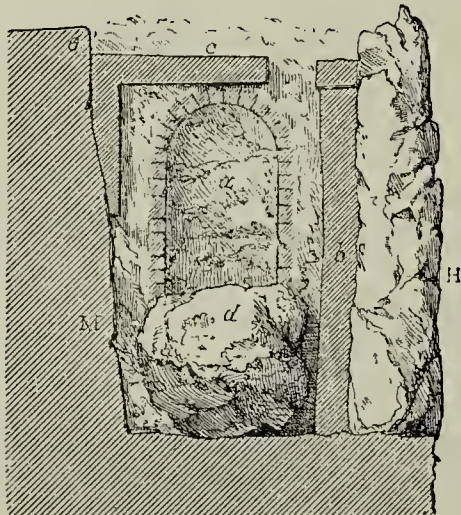

FIG. 24.—The Sanctuary. Plan of chamber. WEBER, *Ibid.*

breaks off and rapidly sinks, the ridge we have described is embraced, at a distance, by an external wall. It runs parallel to the two colossal rocks for 30 m. or thereabouts, towards the east, where a low ridge projects from the plateau. It follows the sinuosities of the cliff on the south-east, and forms salient and retreating angles of the utmost nicety (*p*), sweeping round the north-west side of the hill with a mighty curve (B, C, F, in plan).

Here the cliff projects beyond the line of the wall into a kind of pro-

montory, with precipitous sides; the rampart at first follows the ridge, then from F to G, where it terminated, it is carried in a straight line across the valley, and thus becomes a supporting wall to the plateau (Fig. 26). On the south face the rampart only extends as far as the rock M, where a ledge occurs, which it enters at right angles. Beyond it, the side of the hill being almost perpendicular, a wall became superfluous.

The masonry of the rampart throughout, like the walls of the Acropolis, presents great variety. Thus, on the western and part of the eastern face (F, G, D, in plan), it is frankly polygonal; sometimes the courses are horizontal, but with oblique joints (E), whilst at c it very much resembles Hellenic work (Fig. 27). The principal entrance was approached by a flight of steps, which seems to have been on the northern face (g), where the wall breaks off suddenly, leaving a space 1 m. 50 c. wide. According to Weber (from

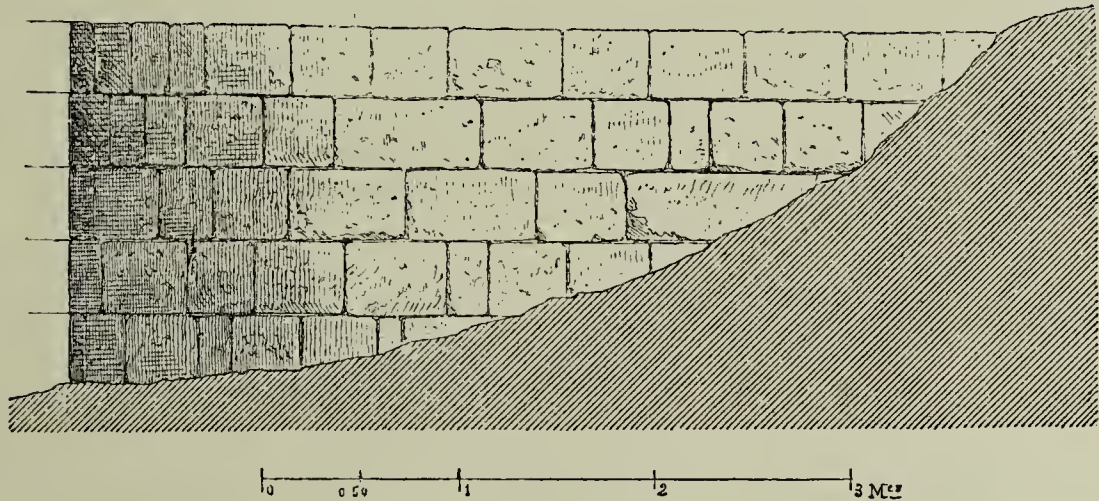

FIG. 25.—Sanctuary. Wall of chamber. WEBER, *Le Sipylos*, Plate III.

whom the foregoing description is taken), no traces of structures, to speak of, exist on the plateau, save the sinking in the northern court already referred to, and some few remains on the southern face (s, t). But these are so characterless as to throw no light on the nature of the original buildings.

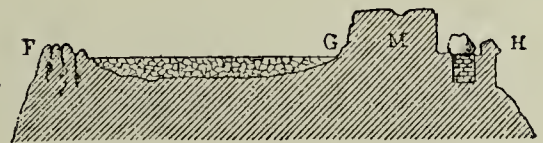
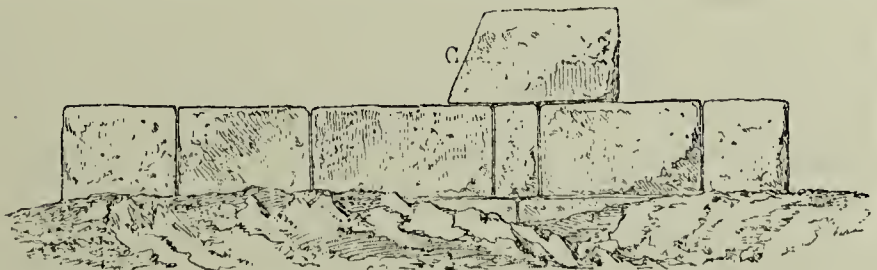

FIG. 26.—Sanctuary. Section through F H. WEBER, *Ibid.*

For what purpose were the ramparts and the chamber erected, is a question to which no certain answer can be given. For although the first notion suggested by the presence of a rampart on an insulated plateau is that of a stronghold, there are features about it which seem to



WEBER, *Ibid.*

FIG. 27.—Sanctuary. Surrounding wall on the north-west.

rebut such an hypothesis. In the first place, the fastness would have been very far removed from human habitation; in the

second place, the wall lacks the stoutness of that which crowns the ridge above the Tantaleis tomb, for nowhere is it more than 1 m. 20 c. thick; finally, there is no ditch, and it would have opposed a feeble barrier to the assailants. On the other hand, it harmonizes with our conception of a wall, the function of which was to enclose a given space adjoining a sanctuary; investing it with the character of a *τεμενος*, consecrated ground. How are we to explain, on the theory of a fortified place, the existence of the inner chamber scooped out of the solid rock with so much care? In what way could it have helped the defence? It is neither a silo nor a cistern. Neither is it a tomb; for both it and the chamber it contains are far beyond the usual dimensions—which hardly vary—of a mortuary oven, *i.e.* an oven-shaped tomb. Then, too, the walls bear no marks of having supported a roof; and we can scarcely conceive the possibility that the dead were left to themselves in the open.¹ Unaccountable as this would have been elsewhere, it would have been passing strange in this region, where hard by existed tombs with circular base; that is to say, the well-attested type of the tribe long settled here. Nor can we conceive that a primitive race would have laboriously excavated a spacious and well-enclosed area around a single tomb.

Setting aside similar explanations, the only possible conjecture left to us is that of a very ancient temple, with niche (the chamber) reserved for the symbol or the image of the deity worshipped in this "high place." By the light of what we know of the local cults, this deity can be no other than Cybele, enthroned among these hills. It is not to be supposed for a single moment that a statue was set up in this trench; but, as at Pessinus, it was doubtless a rude stone of peculiar shape. The arrangement of the sanctuary being considered, would point to an age when no statues were known, save colossal figures in high relief, cut in the rock, from which they were as yet unable to free themselves. In this hypothesis the general dispositions fall into place of their own accord, and become as clear as daylight. The area corresponded to those rude stone circles we have studied in Syria; within its enclosure the crowd of the faithful gathered themselves to celebrate

¹ M. Ramsay is inclined to see a fortress, which in the Greek period was already in a ruinous state, but continued to be visited for the sake of its sanctuary (*Newly discovered Sites*, p. 73).

their public rites.¹ The two rocky ledges at either end of the ridge overhanging the courts were as two gigantic altars on which sacrifices were offered in the light of day, *coram populo*. As to the *bætylus*, the object of such homage, its rocky frame and double wall were sufficient protection against the weather, and, owing to the narrow entrance, the vast majority of the vulgar throng could be kept out, and none but the select few allowed to enter.

Was this the "Hieron of Mother Plastene," specified by Pausanias, and due to the early settlers on Sipylus, the same which the Greek colonists of Smyrna continued to surround with religious awe? In that case we must believe the report that the highest summit of the Iamanlar-Dagh, northward of it, was called the "throne of Pelops."² One of the faces of this particular peak towards the apex is broken off, and forms a ledge with a far-off resemblance to a gigantic seat. Its appellation was due to its peculiar shape, which was likely to strike the fancy of a primitive people; instances of which are to be found all over the world. Thus in many a French district are hills popularly nicknamed *Chaises de Gargantua*.³

Not to omit any item on this side of Sipylus, it remains to notice two fragments of fortified enclosures. One is found eastward of the necropolis which contains the Tantaleis tomb, on the lowest spur of the mountain, but close to it. It covers a much larger area than the citadel, and has its angles protected by round towers. To be brief, examination of the sites and of the walls leads to the conclusion that we are confronted by the Acropolis of the Smyrna of Homer.⁴

The second *enceinte* is found on the road which goes across the Belcaive Pass, along the valleys of the Nif Chaï and the Hermus, beyond the Sipylus barrier. It is the old road which from the remotest antiquity was followed by the inland trade of Smyrna, down to the opening of the railway (Fig. 7). North of the pass rises a conical hill, isolated from the mountain range on the south, and thus rendered a conspicuous object from every point of the Bournabat plain. On the summit are distinct traces of old

¹ With regard to the Syrian *bâmoth*, see *Hist. of Art*, tom. iv. ch. v. s. 2.

² Consult WEBER, *Le Sipylos*, pp. 30, 31. He remarks that the monuments referred to by Pausanias are all near the old road, which from Cordelio runs across the Iamanlar-Dagh to Menemen in the Hermus valley, and is still used by the natives when the country is flooded.

³ Arthur's Seat, near Edinburgh, and many more will occur to the reader.—Trs.

⁴ WEBER, *loc. cit.*, pp. 25, 26, Plate I.

walls, obviously remains of an ancient city and of its stronghold.¹ Some few yards below, eastward, is an extensive plateau, begirt by a wall. Then about midway up the hill, between two rocky ridges which descend towards the Turkish café (Belcaive), a wall 6 m. 50 c. thick, and here and there from 2 m. to 3 m. high, runs for about 50 m. with direction from north-west to south-west. Like the Acropolis of the Iamanlar-Dagh, its style of masonry exhibits great variety. Certain blocks left in the rough are very irregular; elsewhere the courses are nearly horizontal, set with dressed stones by no means of uniform calibre; nevertheless, the prevailing system is still polygonal. The rock was cut in places, and abutting on the wall is a circular ruin in which M. Weber recognizes a tumulus. "Fragments of pottery strew the ground; most are plain red without ornament, and not a few are of fine black ware, like ancient Greek vases, with here and there a bit of archaic make."²

From the day when the tribe settled here began to build the little town whose harbour is now covered by the Bournabat level, they must have been alive to the importance of closing the pass through which alone, by following the course of the Hermus, the enemy could descend upon them. Part of the population, therefore, occupied a post within easy reach of the plain and the slopes proper to cultivation, whence the defile could be easily guarded. A situation offering so many advantages must have tempted Greek colonists—who probably superseded the primitive settlers—to occupy the site and make use of the means of defence erected by former generations, whose name had passed out of men's memory.

The second group of the early monuments of Sipylus is found on its northern slope, in the Manissa-Dagh, eastward of the old site of Magnesia. Scholars had surmised that the race which, whilst cultivating the fertile plain of the Hermus, had its places of worship, its shelters, and tombs in the depths of the mountain, above or at the base of its formidable escarp, had probably left other traces of its activity in the neighbourhood of the colossal statue of their famous goddess Cybele. And this expectation recent researches have fully realized.

As you leave Manissa, coasting Sipylus up to the head of the valley, on some six hundred yards beyond the gigantic statue of Cybele, you suddenly come upon a narrow gorge, flanked by

¹ RAMSAY, *Newly discovered Sites*, etc., pp. 63-68; WEBER, *Le Sipylos*, pp. 114, 115.

² Ramsay, *loc. cit.*

vertical walls about 150 m. high (Fig. 28). About the middle of the gorge juts out a kind of spur with very precipitous rugged sides, called by the natives Iarik Kaia (Twisted Stone), which, they tell you, bears on its summit the ruins of an old castle, Palæo Kastro. Of late years travellers have frequently succeeded in getting to the top of the bare cliff, a performance which requires elasticity of limb and a steady head; for, says Professor Sayce, you have to climb up, catching now at a projecting stone, now at some bush growing in the cleft of the rock. It appears that in olden times a path, wide enough for a mule, partly cut in the living rock, partly supported by artificial walls which were carried across

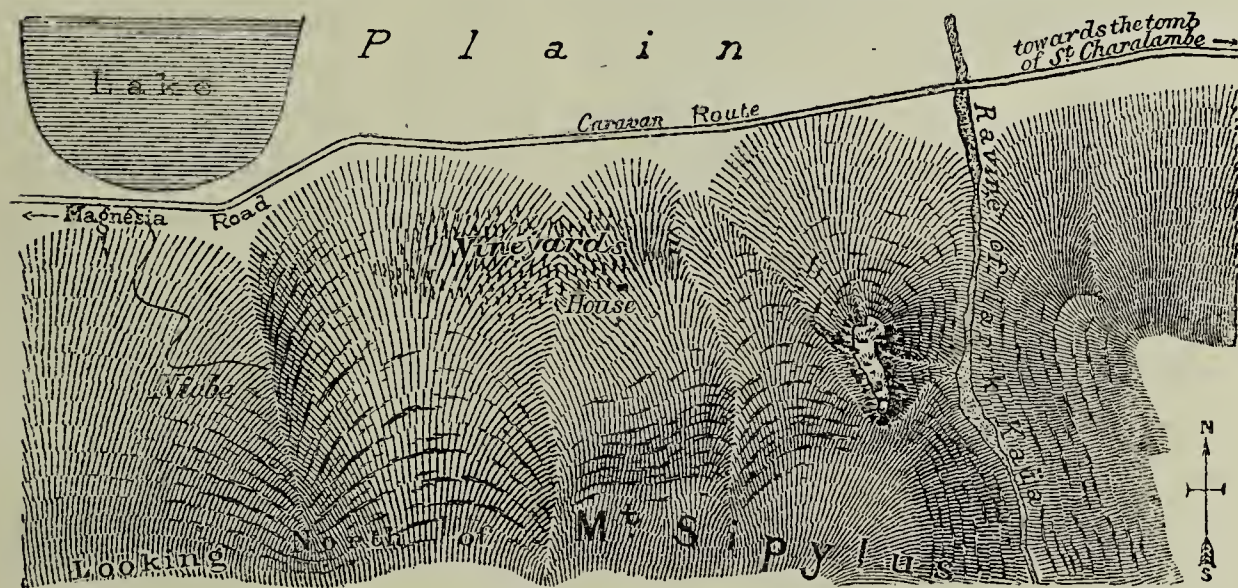

FIG. 28.—Topographic sketch of northern slope of Sipylus, east of Magnesia.

the chasm, led to the castle. Though it cannot now be used, it may still be traced in places "half hidden under a growth of myrtles and stones." A little further a grotto, 10 m. deep, is sighted, whose opening has been enlarged by human agency. Then comes a gateway, one of whose side posts was built and the other hewn in the rock—doubtless a sentry-box which served to guard and close the path. Presently, rising straight before you, is a rock which no sure-footed animal, let alone man, could possibly climb. But as you turn the corner there appears a split in the stone, which in Switzerland would be called a "chimney," and into this you disappear along with your guide. After feeling your way about for a few minutes you suddenly emerge on the upper ridge, now only accessible through this passage. A staircase, partly destroyed by a huge boulder which broke away from the cliff above, but of which steps may be seen hidden away under

the brushwood, formerly led to the platform. It is an elongated plateau, 150 m. by 25 m., with a steep declivity; its highest point is 370 m. above sea-level, and its lowest 325 m., yielding a difference of 45 m. (Fig. 29). The site looks almost too forbidding for human habitation; nevertheless five or six cisterns, bottle-shaped, are met with, along with remains of houses in stages, on to the very brim of this thin, dizzy ridge.



FIG. 29.—Topographic sketch. After Dr. Fabricius.

Thanks to the incline of the ground, the rocky mass was cut away in such a fashion that only the side and back walls, and sometimes the partitions between one apartment and another, were left adhering to the soil (Figs. 30, 31). The façade, now disappeared, was artificial, and must have been constructed with adobes and stone chips; for nowhere do we find blocks of a certain calibre, real prepared stones. On the other hand, burnt tiles are not rare; some are quite plain, others of a more complicated make served to cover the joints, thus implying that a certain degree of care was bestowed upon the roof. The number of these dwellings, connected one with

the other by short flights of steps, is computed at twenty-five. To the rear of the uppermost a rectangular excavation, 1 m. 10 c. by 1 m. 55 c., by 1 m. 30 c. deep, has been cut in the living rock. Its faces are finely polished (Figs. 32, 33). M. Humann, who was the first to describe this tiny, quaint Acropolis, is inclined to recognize it as the throne of Pelops, which used to be shown on the summit of the hill above the Hieron of Mother Plastene.¹

¹ Our description is abridged from M. HUMANN'S *Ein Ausflug in den Sipylos*, p. 10, of which a new illustrated edition has just appeared, entitled *Die Tantalosburg mittheilungen*, 1888. To Dr. Fabricius of Berlin we are indebted for Figs. 28, 29, 30, 33, as well as a discursive letter upon Iarik Kaïa, which he visited in

What tends to give colouring to this hypothesis is the fact that on the edge of the plain, near the entrance to this narrow pass, recent excava-

tions have brought to light the site of a temple of this goddess, where she was addressed by the name of *Μήτηρ Πλαστηνή*; that is to say, the

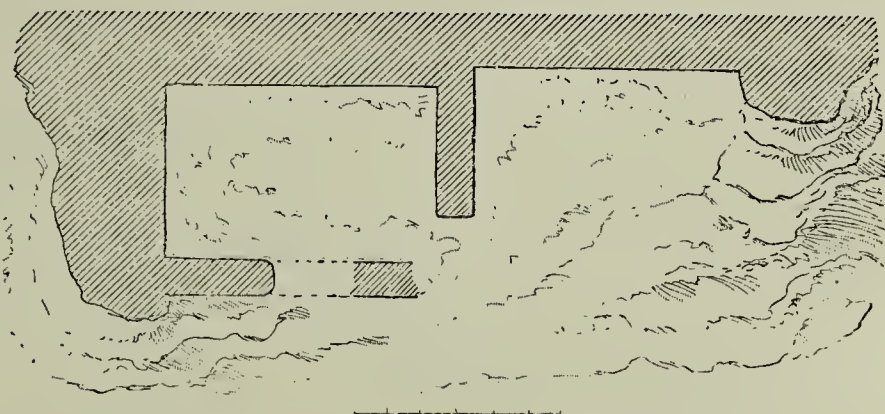

FIG. 30.—Plan of houses. After Dr. Fabricius.

very title given her by Pausanias.¹ Striking though this may be as a coincidence, it fails to carry weight with it. In the first place, the feeble salience of the rock which, according to him, was held as the seat of the great ancestor, was not visible from below. In the second place, even when the path was in its prime, the difficulty of ascent was too serious a drawback to have tempted many people making the experiment.

Obviously the throne of Pelops was a conspicuous feature in the 1885. Consult also WEBER, *Le Sipylos*, pp. 118, 119, and Prof. RAMSAY, *Sipylos and Cybele*, pp. 35-37.

¹ The name of *Πλαστηνή*, under which this goddess was worshipped here, occurs in ancient manuscripts. But as neither inscriptions nor coins have it, Sichelis, Dindorf, and after him Schubert, took upon themselves to replace *Πλαστηνή* by *Πλακιανή*. It is now universally acknowledged that the manuscripts were correct, an example which should warn editors to pause ere they tamper with ancient texts; notably in relation to proper names and local epithets which, though unknown to fame, were none the less current in the districts where they are found. *Πλακιανή* was a surname of Cybele which obtained in the Troad. The temple in question is said to be about an hour eastward of Magnesia, e.g. hard by the statue of the goddess. On its site several bas-reliefs of a votive character have been discovered, representing a woman accompanied by lions, in which it is not difficult to recognize Cybele. On one of the sculptures appears the following inscription, published in the *Bulletin de Correspondence hellénique*, 1887, p. 300:—

ΜΗΤΡΟΔΩΡΑ ΑΠΟΛΛΑ
ΜΗΤΡΙ ΠΛΑΣΤΗΝΗ
ΕΥΧΗΝ.

Μητροδώρα Ἀπολλᾶ
μητρὶ Πλαστηνῆ
εὐχὴν.

Another inscription, in very good preservation, mentions the temple in which the votive monuments in question were deposited, along with one Apollonius Skitalas, son of Alexander, who is said to have built or rather repaired it. What is wanted here is a squeeze, so as to learn whether the restoration dates from the Seleucidæ or the Roman empire.

view, with some kind of resemblance to a seat, upon which popular

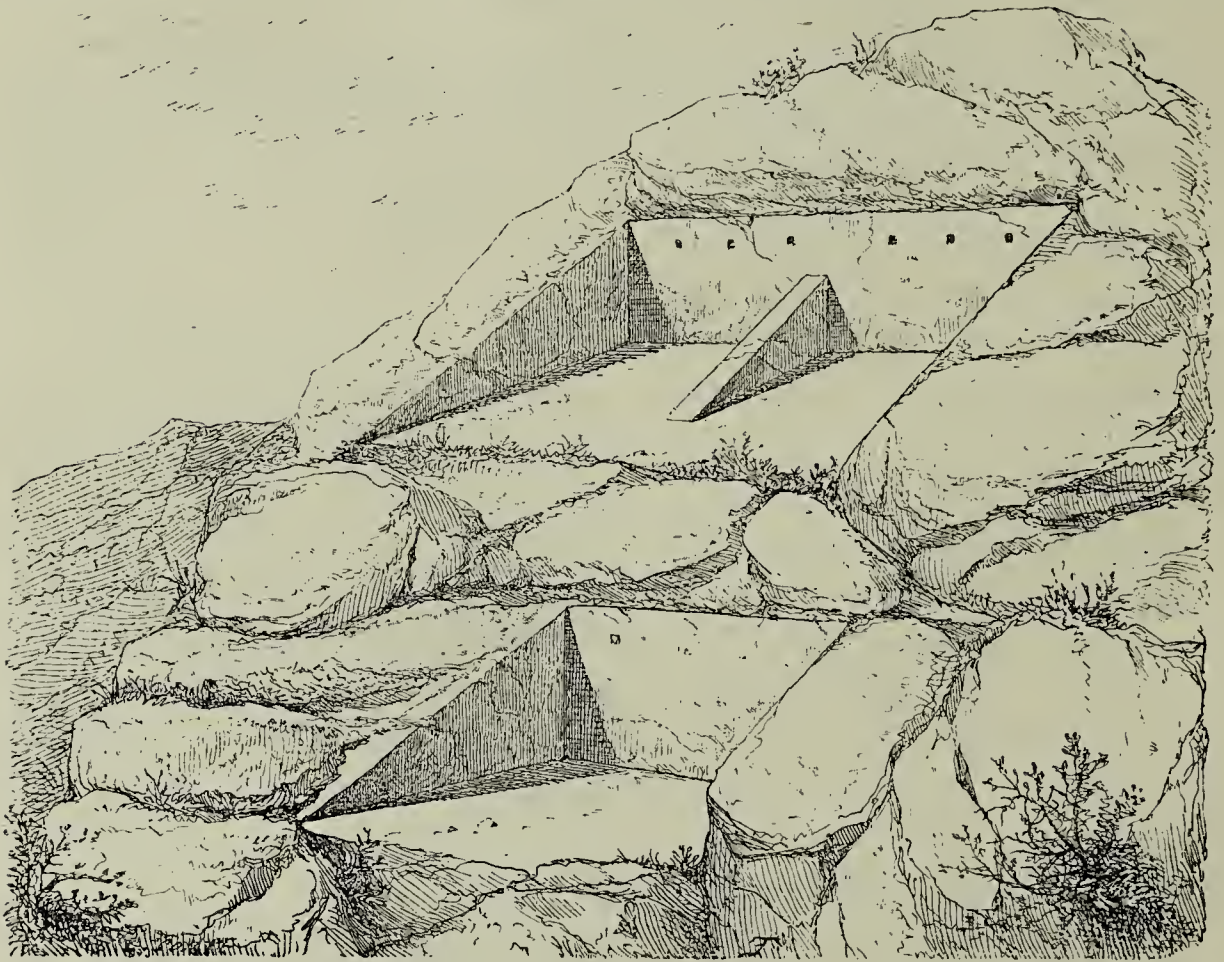

FIG. 31.—Rock-cut dwellings. From Ch. Humann.



FIG. 32.—Niche hollowed in the rock. From a photograph of Charles Humann.

fancy had fastened, as it had for the rock which recalled to those in the humour for it the sitting form of a woman "grieving because

her children were not." We rather incline to believe, with Dr. Fabricius, that this was a vedette, whence the watch, comfortably sheltered behind the cliff, had a full view of the path from its first winding up the steep side of the hill.¹

We have not seen the ruins specified by Humann. Bearing in mind, however, the straits to which the Mussulman conquest reduced the populations of Asia Minor, we should be tempted to think that a village, almost as inaccessible as an eyrie, might, after all, date from the Byzantine rule, but for the fact that M. Humann seems to have no misgivings as to the high antiquity of these remains. Needless to add that the avowed opinion of so experienced an explorer of the Asiatic peninsula is entitled to serious consideration.² In its favour

are those cisterns and domestic dwellings excavated in the living rock, together with the kind of parapet, 1 m. high, obtained in the rocky mass by the same process, which is visible on many a point along the edge of the precipice.³ Similar structures, reserved for the most part in the cliff upholding them, have struck all travellers who have seen them with the strong resemblance they bear to those on the Pnix at Athens.

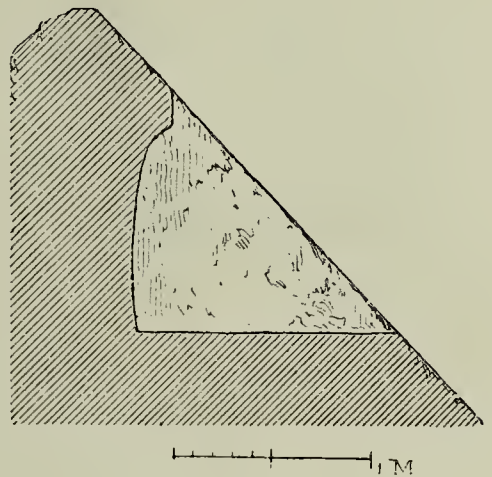

FIG. 33.—Niche hollowed in the rock. Longitudinal section. After Dr. Fabricius.

Such constructions (we have adduced and shall yet adduce numerous instances) were of long standing, and lasted many centuries with the older inhabitants of these provinces, until a more advanced culture caused them to adopt a more convenient style.⁴ Our leanings are all for considering this elevated site as the Phrygian Acropolis, where the population of the town below could find temporary shelter whenever a sudden panic overtook

¹ M. Fabricius admits the possibility that the term "throne of Pelops," under which the vedette is popularly known, may be due to a late period.

² MM. Ramsay and Fabricius are equally positive on the subject.

³ The detail is due to M. Ramsay, *loc. cit.*, p. 36.

⁴ M. RAMSAY (*Sipylos and Cybele*) states that, besides multitudinous pieces of plain red ware, he picked up a fragment of black pottery, recalling Greek vases. No conclusion, however, can be reached from a single piece of this kind. In the early stage of Hellenic civilization the village may have been inhabited by woodmen or other colonists who supported themselves from the land produce.

them. The town in question may have been Tantalus, which, according to Pliny, preceded Magnesia, and was destroyed in one

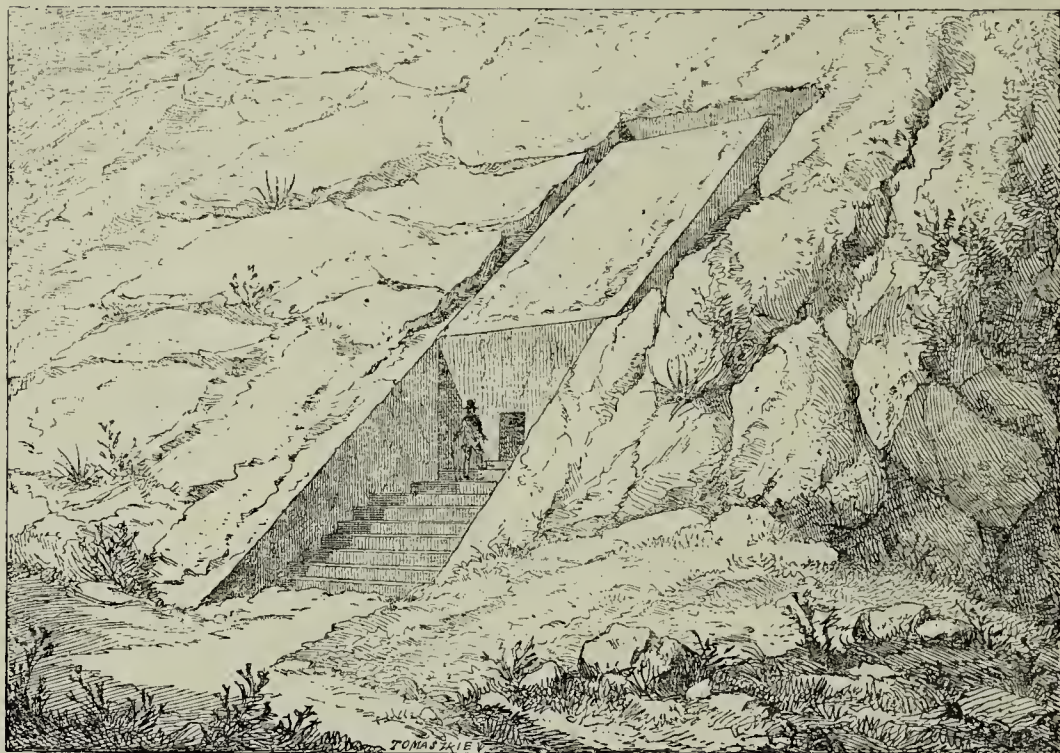

FIG. 34.—Tomb hallowed in the rock, near Magnesia. Perspective view. HUMANN, *Ausflug*, Fig. 1.

of those seismic convulsions of frequent occurrence along the coast.¹ The appalling earthquake of 1880 is vividly remembered by the

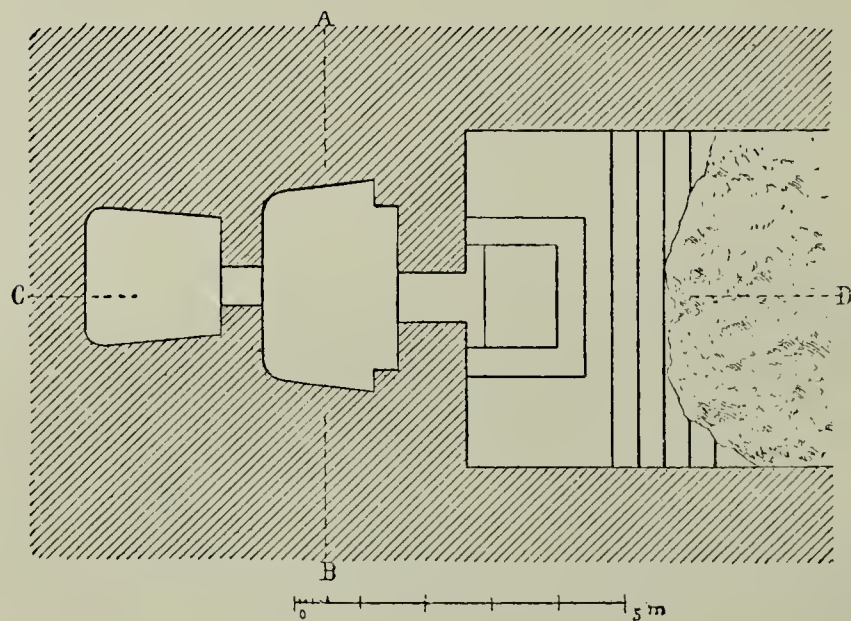

FIG. 35.—Tomb near Magnesia. Plan. HUMANN, *Ausflug*, Fig. 3.

Smyrnians, when broad masses of the mountain, being loosened, rolled down into the plain, with trees and crops adhering. In like manner Tantalus was buried in Lake Salæ (now a pond at the entrance of the pass leading to

¹ M. HUMANN (*Ausflug*, etc., p. 7) does not seem to be aware that the tomb under notice was published before him by STEWART, *Ancient Monuments*, Plate II. The drawing of the latter, however, is so imperfect as to be worthless for the purposes of science. Weber's sketches (*Trois tombeaux archaïques de Phocée*, pp.

the fortress), whose waters reflected the ruinous walls of the antique city.

To the people who preceded the first Greek colonists on Hermus (founders of Magnesia) should likewise be attributed a funereal monument, met with about four hundred yards east of the ravine (Fig. 34). It is known in the country as the tomb of St. Charalambe, and is entirely scooped out of the living rock, in a

talus which dips to the south-west at an angle of forty-five degrees. In this ledge of rocks was first sunk

a broad staircase open to the sky, whose lower steps are hidden under accumulated earth. It led to a platform, in the centre

of which a two-stepped landing has been reserved. The topmost step is level with a

passage which gives access to a first chamber, followed by

another corridor and a smaller

chamber

(Figs.

35, 36).

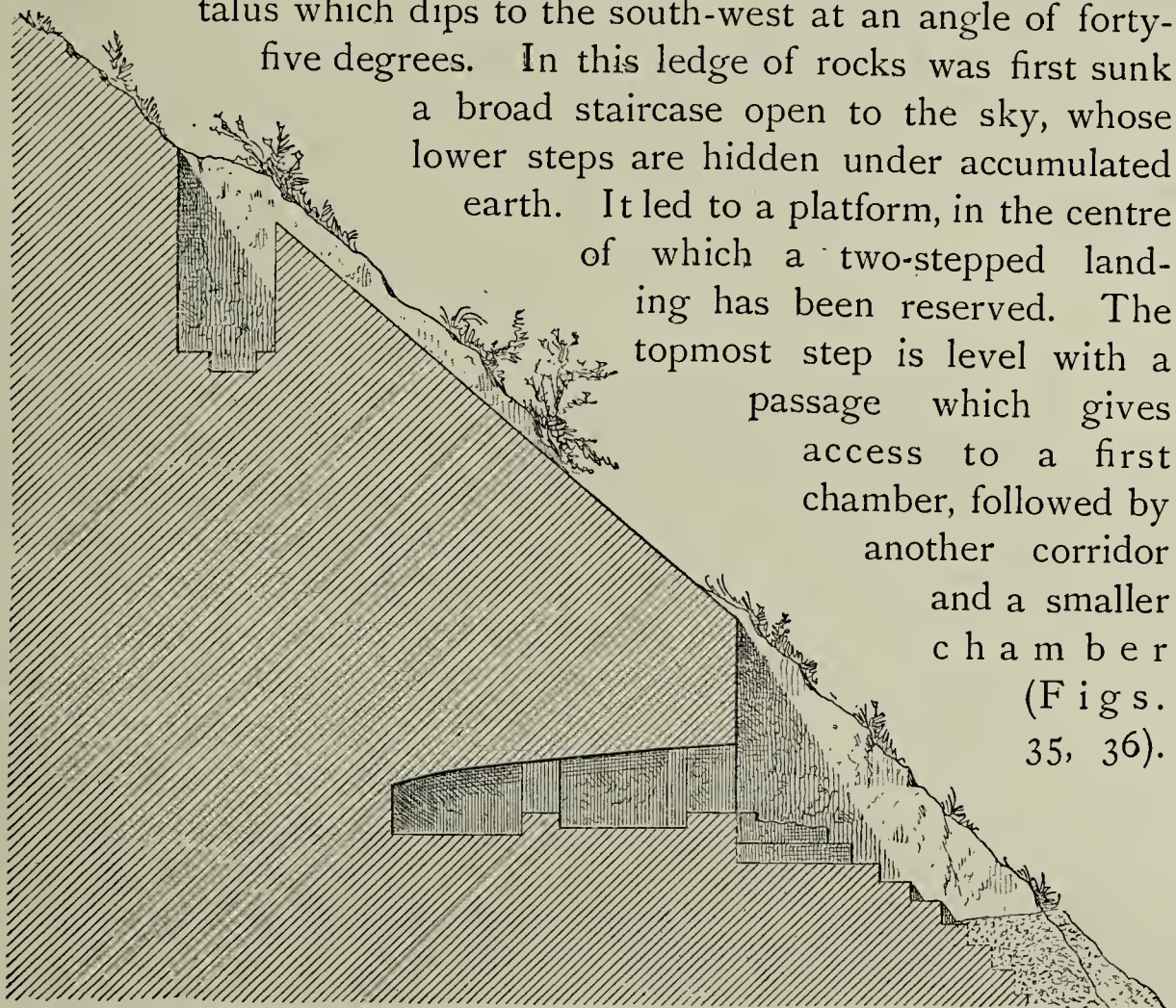

0 1 5 10 M^s

FIG. 36.—Tomb near Magnesia. Longitudinal section. HUMANN, *Ausflug*, Fig. 2.

The ceiling of both apartments is slightly arched, its height diminishing from front to back, and the result is a somewhat oven-like aspect (Fig. 37). The two doorways are not on the same axis; that of the inner is a little to the west as regards the exterior opening. There are no signs of troughs or stone couches, but along the western wall, a little above the ground, runs a double ledge, upon which rested the heads of the corpses laid out on the

136-138, Figs. 11-15) agree in all essentials with M. Humann's illustrations. See also RAMSAY, *Sipylos and Cybele*, p. 37.

floor of the mortuary chamber. The ledge is non-existent on the opposite wall.

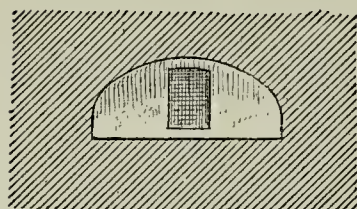

FIG. 37.—Tomb near Magnesia. Transverse section. WEBER, *Trois tombeaux*, Fig. 13.

About the exterior doorway no trace of hinges or frame was found. The passage must have been closed by a heavy slab rolled up against the opening, which may have been broken in early days by treasure-seekers. The inner work is rudimentary enough. The stone-cutters reserved all their thought and care to smoothing and polishing the outer faces; this they did so well and thoroughly as to leave no mark of the chisel. Above, the hypogee table, 9 m. 50 c. by 5 m. 60 c., was levelled out, with a deep groove which

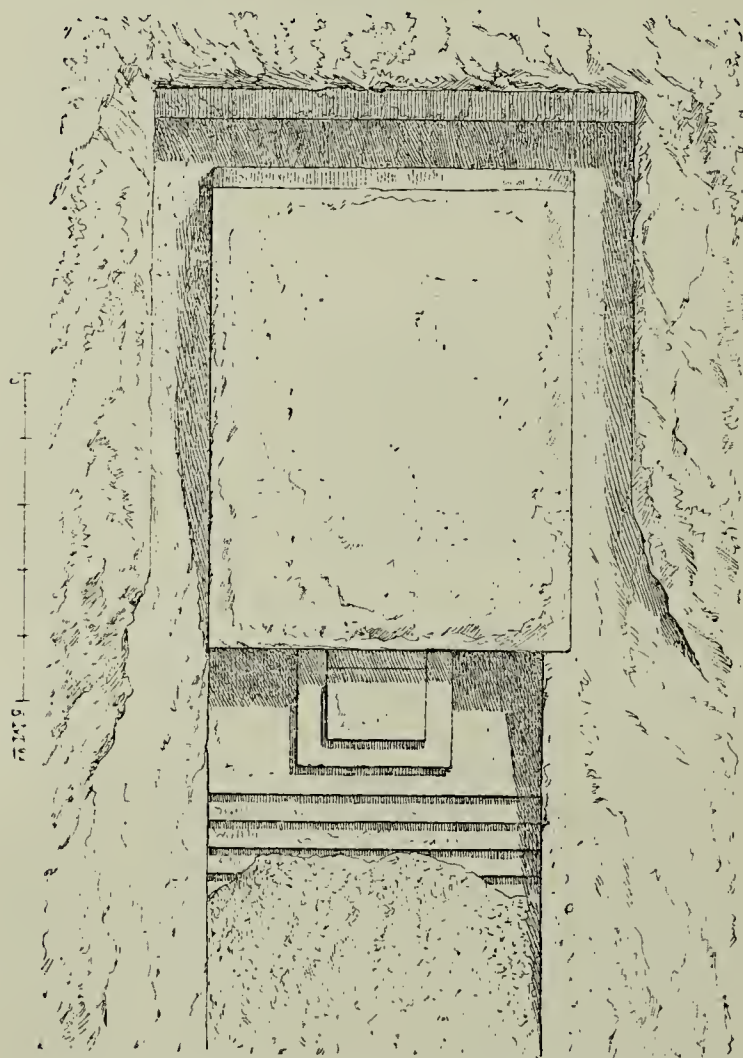

FIG. 38.—Tomb near Magnesia. Horizontal projection of upper part. HUMANN, *Ausflug*, Fig. 5.

separates it from the stony mass by which it is enframed (Fig. 38).

The advantages of a similar arrangement are twofold: despite its simplicity it invests the whole with a monumental aspect, whilst it serves to isolate the tomb, and to guard it as well. The rain water that falls on the surface of the rock is thus collected in a double gutter and discharged on either side some distance in front. Thanks to this precautionary measure, the façade is unimpaired, and looks almost as fresh as if carved but yesterday. Nevertheless

not one among the explorers who have studied this hypogee hesitates in assigning to it a remote antiquity. There is no inscription, nor the slightest sign of mouldings which might indicate a

Greek origin ; the processes resorted to for its erection are identical with those met with in the Phrygian tombs of the Rhyndacus and the Sangarius valleys. Here, too, the effort to isolate the grave-chambers and provide a hollow space, more or less complete, between it and the mass of stone in which it has been hollowed, is occasionally seen. For the rest, the guiding principle and the data are exactly similar ; although the frontispiece has been given a fixed and sharply defined shape, it none the less preserves a solid and severe rusticity, in perfect accord with the grand plans of the mountain, and the broken lines of the native rock which covers and enframes it. Two other tombs, lately discovered, should be added

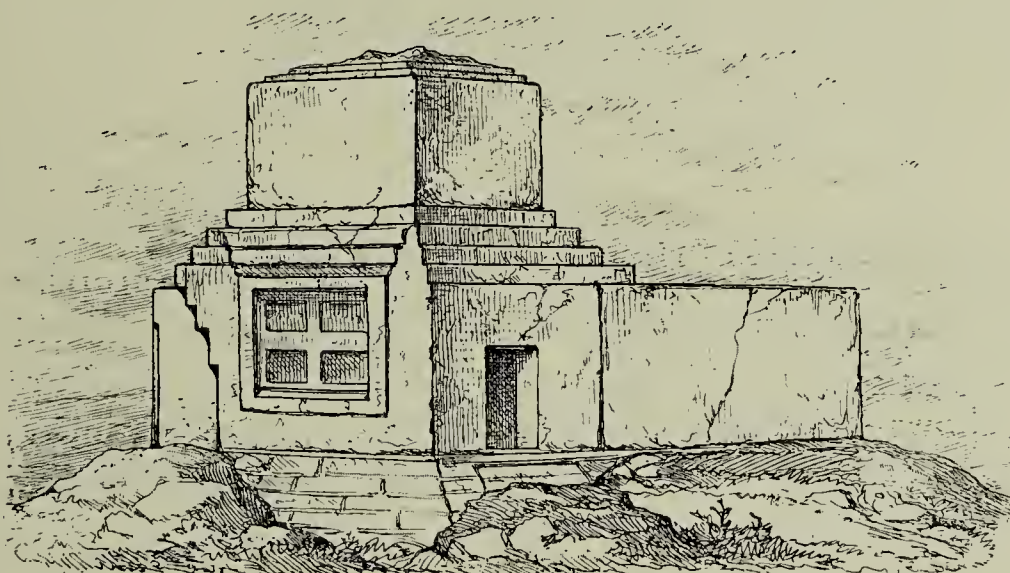

FIG. 39.—Tomb near Phocæa. WEBER, *Trois tombeaux*, Fig. 6.

to complete the number of monuments found in the region of Hermus. They are said to be old, due, perhaps, to the age which preceded the birth of the Greek cities.¹ One, called by the Turks Sheitan Haman (the Devil's Bath), is hard by Phocæa ; and the other, which bears the Greek name of I Pelekiti, is about two hours' walk eastward of the ancient ruins of the same city, near the road which leads to Menenem. There is nothing remarkable about the first. Like the Charalambe tomb, it consists of two chambers, but in the floor of the inner apartment was hollowed a grave in the form of a trough.² The other is somewhat curious.³ The im-

¹ WEBER, *Trois tombeaux*, etc., pp. 129-136.

² See Weber's plan, sections and elevations.

³ M. Solomon Reinach informs me that the above tomb was published as far back as 1831, in 1 vol. 18mo, now very rare, entitled *Fragments d'un Voyage en Italie, en Grèce, et en Asie*, 1829-1830, par Gautier d'Arc, Consul de France.

pression it produces is that of a small country church with a square tower (Fig. 39). Thus, upon a paralleliped base, 8 m. 80 c. by

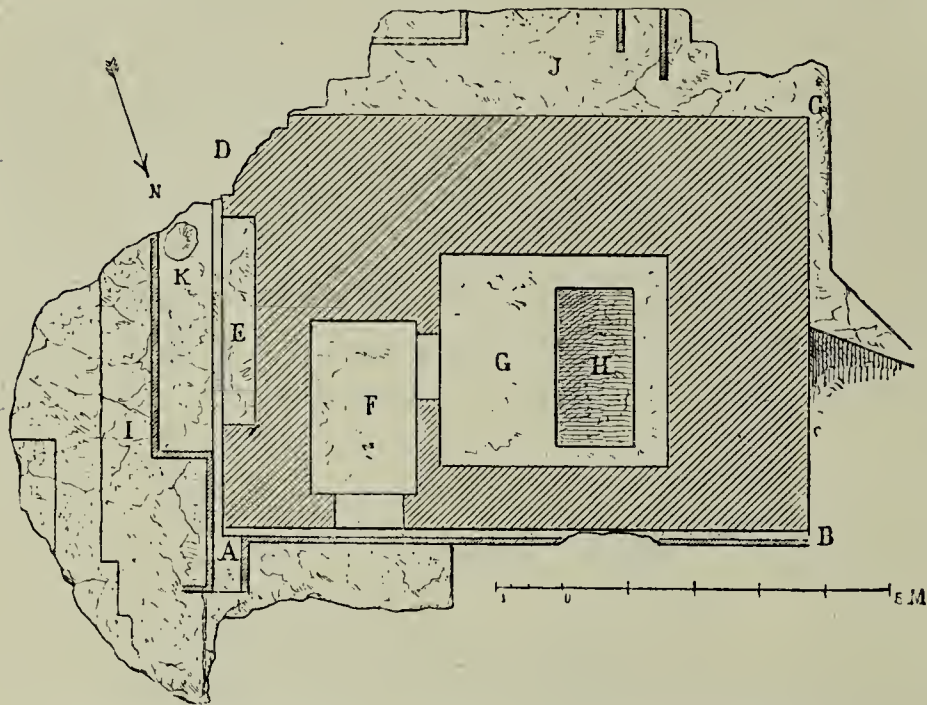

FIG. 40.—Tomb near Phocæa. Plan. WEBER, *Trois tombeaux*, Fig. 7.

6 m. 25 c. by 2 m. 40 c. high, have been cut four grades which were ascended on the eastern side; and on these, again was left a cubical block, 1 m. 90 c. in height, surmounted by two low steps. The monument did not end here, for on the top appear marks as of some object torn off. This our illustration, although on a reduced scale, shows very distinctly. Was the crowning member ornamental, a “stepped”

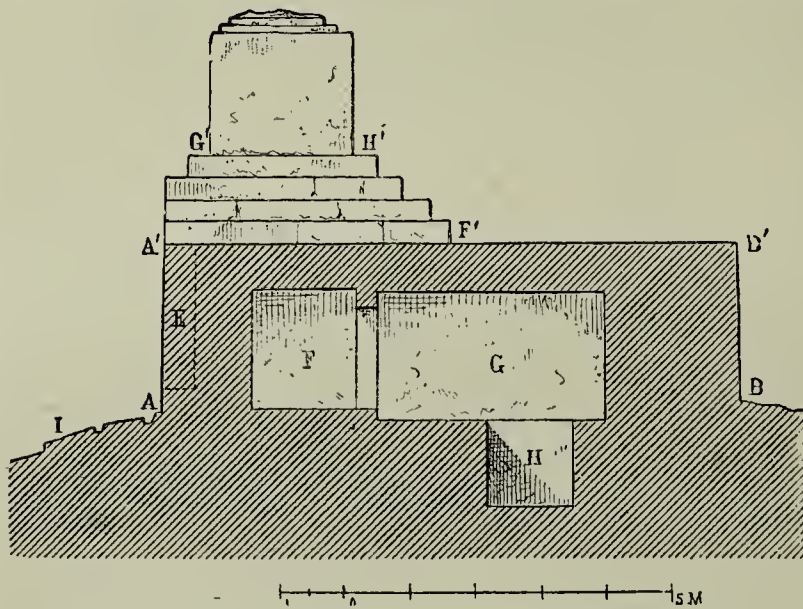

FIG. 41.—Tomb near Phocæa. Longitudinal section. WEBER, *Trois tombeaux*, Fig. 8.

pyramid, rosette, or symbolic device, like the phallus of the tombs around Bour-nabat? To this question no answer can be given, for the breaking off has been too cleanly done to admit even of conjecture. But if the terminal form is sadly to seek, the internal dispositions

The author was a member of the Société Royale des Antiquaires, a fact which he does not seem to have remembered save in this single instance, his short narrative being wholly taken up with picturesque and sprightly anecdotes of a more or less personal character.

are very well preserved (Figs. 40, 41). A door leading to a kind of small ante-room opens in the northern wall, F, whence the chambered grave, properly so called, is entered. The ceilings are flat, and the grave is a trough cut in the floor, H. As at Charalambe here also, the skill of the artist was chiefly directed towards the exterior; be it in polishing the rock surface around the base, cutting grooves on the north and south sides, I, J, for the outflow of the water, or piercing the small circular tank, K, in one of the corners. The north, south, and west faces are quite plain. On the other hand, the eastern face is profusely decorated: first, by an elongated window-shaped niche, divided into four compartments; then a cornice with ornamental ancone slightly salient beyond the rocky wall. On this side the pyramidal base of the cubical block has no steps. Despite these irregularities, in its pristine state, the tomb from its very quaint appearance was not wanting in attractiveness.

When we drew up our list of the older monuments of Sipylus, or at least of the most noteworthy, nothing was said about sculpture: not because the art for that period was unrepresented, since even at the present hour are works of the highest interest, such as the bas-reliefs of Sesostris, described by Herodotus, and the Cybele of Mount Codine, seen by Pausanias; but because the inscriptions about these images prove that they were executed in the period preceding the introduction of letters derived from the Phœnician alphabet, when characters akin to the Hamathite obtained throughout Asia Minor. Hence we were obliged to class the figures under notice with the series of monuments which, for want of a better name, we have termed Hittite. To these sculptures we have nothing to add, except a bust discovered by M. Spiegelthal near the village of Bouja, situated in a mountain eastward of Smyrna, called Tashtali.¹ His description, which we borrow, was written before the mutilation of the monument by the fanatic natives. M. Dennis, her Majesty's Consul at Smyrna, had it removed by night so as to save it from further dilapidation, and secretly despatched to the British Museum in 1869.

To quote from the German explorer: as you ascend the path leading to the alpine village of Bouja you pass a sinking of some 8 to 10 m. deep, and 100 m. long, surrounded by a wall composed

¹ A. MARTIN, *Trois Monuments des environs de Smyrne, lettre à M. G. Perrot* (*Revue Arché.*, Nouvelle Série, tom. xxxi. pp. 321-330).

of stone blocks piled one upon the other without cement. At one end of the depression, pierced in the solid rock, is a kind of arcade which opens into a grotto extending far into the depths of the mountain, but which is choked up by the falling away of the calcareous stone. On either side of the grotto are stone seats, finely polished. Externally, right and left of the doorway, runs a gallery one metre wide, which seems to have been made to facilitate the duty of the watch set to guard the cavern. The grotto was



FIG. 42.—Rock-cut bust. Drawn by A. Martin.

originally entered by a staircase, the lower steps of which are now buried under rubbish, which has gathered to a considerable height in the hollow. It is possible that a clean sweep of the detritus would result in curious finds. Every detail about the grotto indicates that it was formerly a fane. The wall planted in a hollow is assuredly not a defensive wall; whilst the rock-cut benches inside the grotto, and in especial the bust which only a few years ago (1868)¹ stood over the doorway (Fig. 42), are as unlike what we should expect to find around a fortified enclosure as can well be

¹ WEBER (*I.e. Sipylos*, p. 113) says, "Une grotte se trouvait *au dessus* de la tête."—TRS.

imagined. The sculpture, 1 m. 50 c. by 60 c., appeared upon a bold salience of the rock. The head looks full face, with flat nose, low retreating forehead, rounded chin, elongated eyes raised at the outer extremities. The hands meet in front; a necklace of large beads is around the neck. The face is quite smooth, and without a trace of beard. Horns appear on either side of the cheeks where ears should have been, recalling the horns of Ammon. The position of the figure over the doorway of a sacred place is conclusive evidence of its being the image of a deity. By what name are we to address him? Were the locality on the mainland of Greece, we could confidently say that a subterranean fane was dedicated to no other than Pan or the Nymphs. Here, however, we are in the realm of that Cybele who maintained her sway over Sipylus and the hilly tract which it overshadows with its mighty crown to the latest times. It may be urged that a smooth face is no sure sign of sex, since it may with equal propriety belong to a youth as to a woman; whilst horns, as a rule, are associated with gods. Ammon, Hercules, personified rivers. But may not horns, as symbols of strength, have been now and again attributed to a goddess, the embodiment of endless creative force, the tamer of wild beasts whom she obliged to draw her chariot? And does not the figure whose body is lost in the depth of the cliff admirably lend itself to represent the Divine Being so intimately allied with the mountain he inhabited as to be called *ἡ μήτηρ ὄρεια*, the mother of the mountain?

This is not the place for attempting even a conjecture as to the date of the monuments we have passed in review. The time, if it should ever come, will be after we have duly studied Phrygia properly so called, where the Phrygian race had, if not its capital—it never owned a place deserving of the title—at least its political and religious centre, its principal sanctuaries and royal necropoles. On the upper course of the Sangarius, monuments are far more numerous; they have, if we may so speak, a first beginning of civil life written upon them, for they bear inscriptions which, despite obscurities, permit us to name with absolute certainty the people who made them, and to fix a proximate date to them. On our home journey from our exploring quest, we shall feel qualified to add to the weight of the hypothesis suggested to us by historical and mythical data; basing it upon resemblances in style, mode of workmanship, and general dispositions. We shall bound over the

vast tracts which as yet have yielded no monuments of ancient date, on to the uplands where the various races which first peopled Asia Minor maintained their customs, traditions, and cults against the encroaching genius of Hellas.

ARCHITECTURAL CHARACTERISTICS OF PHRYGIA PROPER.

It is doubtful whether Asia Minor, rich throughout in beautiful sites and grand scenery, can offer a corner which in picturesqueness will compare with that which may be seen on the western side of the Sangarius, in the neighbourhood of Pessinus, where Strabo informs us (XII. v. 3) that in his day the inhabitants still preserved the memory of their kings. The region in which the relics connected with these old chiefs are found lies about two days' journey to the south-east of Koutahia, a place generally chosen as the starting-point of their journey by travellers. Leaving the town, the way leads across a white dusty plain, but sundown brings you to the low hills, with clustering pines, in advance of the mountains. Here a valley is entered, and a gentle though continuous ascent brings you to the village of Kumbet, the second station after Koutahia, situated 150 m. above the latter.¹ The tedium of the journey is tempered by the beauty of the landscape, which improves with every hour; the country is finely undulated, the hill-tops well timbered, and pines, the great tree of this district, are so artistically grouped along the slopes—where, despite a general dearth of water, great herds find an abundance of grass down to June—as to suggest English scenery. The Iuruk tribe, amidst which we found nightly shelter, owned no fewer than a thousand heads of horned cattle. In summer these semi-nomadic shepherds camp out in egg-shaped tents made of felt, or in shanties built of unsquared timber. The framing is put together without clamps or pins; the beams for the walls are laid side by side as close as possible, and made to project and overlap each other at the four corners. To keep them in place the under beams are mortised to about half their thickness. The roof consists likewise of a rude frame of unsquared beams, horizontally placed at some distance from each

¹ M. E. Guillaume, who was my travelling companion on the occasion, gives the following barometric measurement: Koutahia, 920 m. above sea level; Kumbet, 1060 m.

other and built up so as to form a curvilinear skeleton; upon this are laid square posts as compactly as they can be laid (Figs. 43, 44).¹

The configuration of the soil is very peculiar; for it is neither of the nature of the lowlands, nor can it be called alpine. The whole region from Kumbet to Seid el-Ghazi, Khosrev Pasha

Hissar, is a succession of valleys with flat flooring, from 100 to 1000 m. wide, dipping with slight variations from north to south. The valleys

are separated one from the other by thick formations of rocky masses, 40 to 50 m. in height; now sloping upwards to a narrow ridge, now terminating in table-

lands of some extent (Fig. 45). By reason of the crumbling away of the rock above, their base is a chaotic wilderness of boulders heaped up in confusion

to a considerable height. The ground is undulating throughout, and the rocks rise up into low hills, connected with, albeit they do not belong to, the snow-capped mountains extending far away. Trees of fine growth spring out of the clefts of the rocks. Here

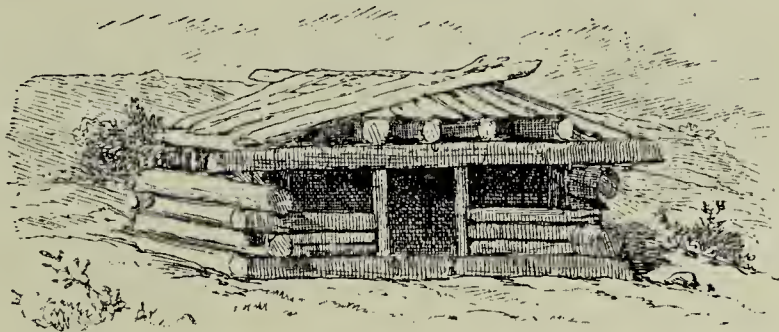

FIG. 43.—Wooden house near Kumbet. After M. E. Guillaume.

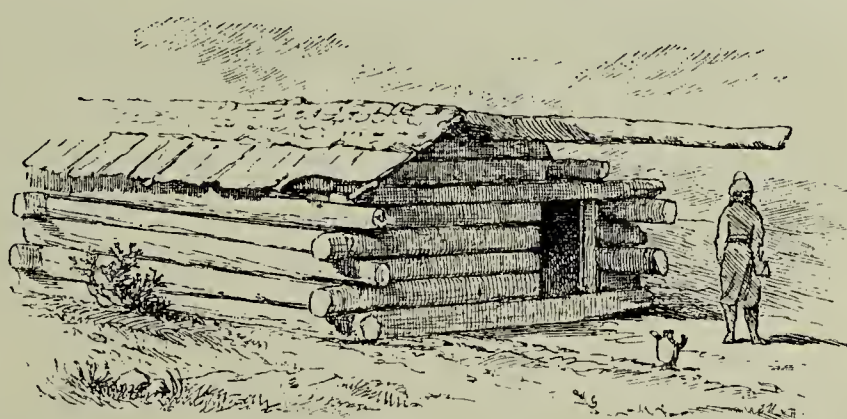

FIG. 44.—Wooden hut near Kumbet. After M. E. Guillaume.

¹ Vitruvius, in his chapter entitled "Origin of Domestic Architecture," describes this mode of building of general acceptance in Asia Minor, notably at Colchis, in the following words:—"Four sets of trees, two in each set, of the length required for the width of the house, are laid parallel to each other on the ground. They are met contrariwise at the extremities by other trees, whose length is equal to the space between the horizontal trunks, so as to form a kind of rough frame. This is then placed upon the perpendicular beams, which form the corners of the house and serve as supporting pillars. Planks are laid across as near to each other as they can be laid," etc. (II. i. 4). In reality the system has always been in vogue wherever a plentiful supply of timber is to be had; for example, in Lycia and towards the Euxine.

and there are volcanic cones broken up into a thousand fantastic forms, in strong contrast with the plain whence they shoot up. The formation is a coarse conglomerate, yellowish in colour, nowhere very hard, yet varying considerably in firmness and density.¹ The salt lakes, and generally the geological formation of the soil, clearly indicate that the central plateau emerged from an inland sea. The waters, raised by successive volcanic efforts, were hemmed in on all sides by a double and triple belt of massive lofty ridges, which they had slowly to undermine and pierce, ere they found an outlet into the oceans sur-

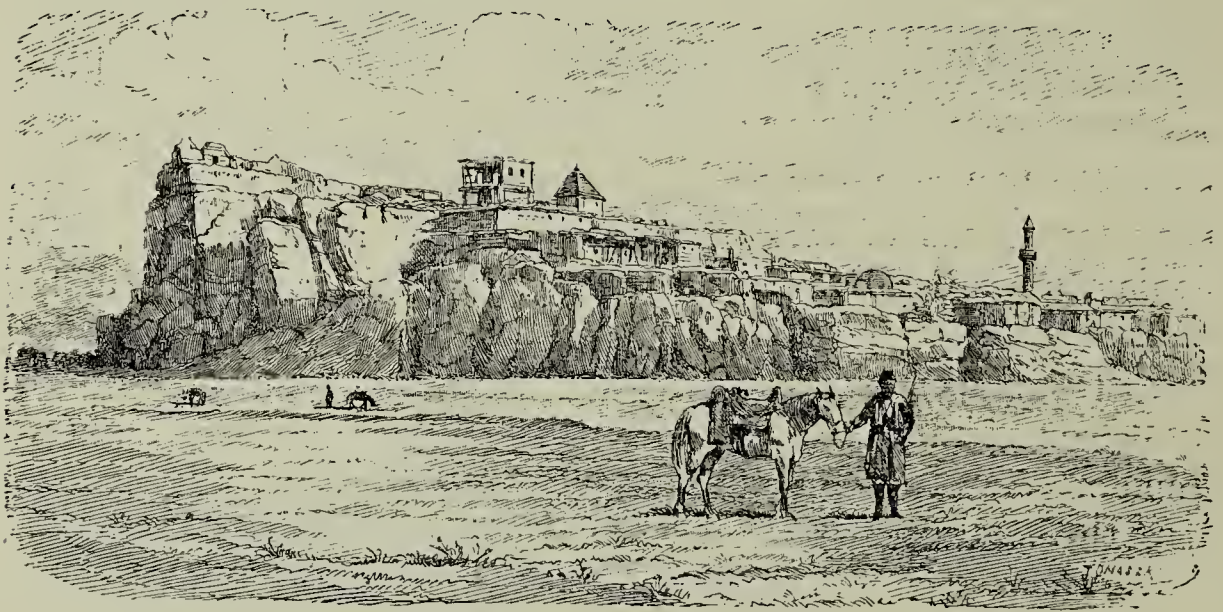

FIG. 45.—General view of Kumbet.²

rounding the peninsula. At first the waters that escaped from the rocky walls were nothing but rivulets; but ere long they gathered themselves into impetuous streams, as they descended the broad grades of the elevated tableland towards the Euxine and the Mediterranean. During their course they often helped to fill lakes that had suddenly emerged and as suddenly disappeared, in one of those upheavals which helped to build up the plateau,

¹ A small fragment of the Midas rock has been handed to me by Professor Ramsay. I had it analyzed by M. Munier-Chalmas, who returned it with the following note:—"The stone I examined is the result of volcanic agency in the Miocene or Pliocene period. It is a rhyolitic tufa, with fragments of pumice and obsidian. The microscope reveals the presence of broken crystals of quartz, orthose, oligoclase, and amphibole, sprinkled in the shapeless mass; along with a fragment of an older rock or micaceous schist with blue crystals."

² The above sketch is by M. Tomakievicz, from a photograph of M. Gustave Fougères, of the French School at Athens. It faces the tomb we study and represent a little further on.

and caused that part of Phrygia which is wholly formed of irruptive rocks, to be called Phrygia Combusta. During these periods, which may be counted by thousands of years, the many streams which descend from these heights carved a tortuous bed around the more friable rocks, the eddy acting as battering-ram in shaping them into every possible contortion of lofty pinnacle and narrow promontories, rending their flanks into dark caves, deep crevices, and fissures, or polishing the hard-grained stone into vertical walls.¹ Strolling about the neighbourhood of Seid el-Ghazi (ancient Nacoleia) I was forcibly reminded of the Forest of Fontainebleau, whose configuration science explains as likewise due to fluvial energy.

Before the primitive inhabitants were provided, as they are at the present day, with forged iron, they could not resist the temptation of excavating their houses into the friable rock they had everywhere at hand. Moreover, even when they had tools with which they could rapidly fell and cut up pines of the required length and size, they continued to take shelter, at least in the winter months, in stone habitations hollowed in the depth of the hill, or those isolated rocks which shoot up on many a point of the valley. The winters are cold here; for, though Kumbet is but 150 metres above the level of the surrounding plain, it is more than 1000 metres above the sea. At such an altitude the nights are fresh, nay, cold throughout the year. Thus, at 6 a.m. on the 12th of June, the thermometer marked six degrees above zero; and albeit the time was summer, we were often kept awake in our wooden huts, by the sharp frosty air, and had to take in turn feeding the fire through the night. Dwellings like these are of a certainty picturesque, but they are positively no protection against the wind, and very little against the rain, which latter penetrates through chinks and fissures large enough for the hand to get through. Nor was it much better when we tried to stop the gaps with straw and clay, for these were presently turned into mud and washed down inside by the driving rain, whilst the chaff, left to itself, was taken up by the wind and tossed about our faces. As for the wraps and blankets we put up before the apertures, they

¹ There was some uncertainty about the name of the site occupied by Seid el-Ghazi. Prynnessus, whose coins during the Roman domination bear the effigy of Midas, was proposed. The researches of Professor Ramsay in 1884 have definitely settled the question. "Prynnessus," he writes, "was at Seulun, three miles south-east of Afium Kara Hissar," on the postal road which runs from this city to Konieh.

only made matters worse, in that they swelled like so many bladders and blew out into the middle of the room, discharging a veritable hurricane about us.

In conditions such as these, it is no wonder that, whilst living in forests, habits which seem to suit regions where timber fails should have persisted for centuries. Writing of the usages in vogue among the Phrygians, Vitruvius employs terms which clearly indicate that the district he has in view is Phrygia Combusta, which joins on Lycaonia, where trees are only seen in gardens.¹ And, indeed, on this side, in the territory of Urgub, Kumbet, and Utch Hissar, the faces of the tufaceous rocks are entirely honeycombed with artificial grottoes.² That some were tombs is rendered indubitable by the inscriptions which accompany them; and it seems no less certain that a vast majority were appropriated to domestic and religious uses, even as they are at the present day. Troglodyte dwellings, it should be remembered, are too deeply rooted in the habits of the people ever to have been out of fashion. Thus, towards the northern extremity of the rock upon which the village is perched, are remains of a spacious mansion, of which a plan was made by Professor Ramsay (Fig. 46). The foundation walls, mostly reserved in the thickness of the mass, are still two and three metres in height. But where the rock failed, in front, recourse was had to masonry set in courses of squared units. Professor Ramsay recognizes the women's quarter in a block of buildings entered by a long winding passage, H, and separated from the rest of the habitation. He finds a bedroom, c, dressing-room, E, and bath-room, F. The floor of the latter is paved with a different stone, and shows a small duct cut through the rocky wall to carry off used water, G.³ The mansion served as

¹ II. i. 5: "Phryges vero, qui campestribus locis sunt habitantes, propter inopiam silvarum egentes materia eligunt tumulos naturales, eosque medios fossura distinctes et itinera perfodientes dilatant spatia quantum natura loci patitur."

² With regard to these Troglodyte hamlets, see *Hist. of Art*, tom. iv. Fig. 389; and MORDTMANN, *Die Troglodyten von Cappadocien* (*Mem. zum Akademien Munchen*, 1859). Strabo reports that in his time native tribes in the Taurus range still lived in caves and grottoes (XII. vi. 5). We observed similar caves at Beibazar and Istamos in the Sangarius basin. The hewing of these chambers is rendered easy by the loose texture of the stone. Thus at Martkhane, near Urgub, Barth slept in an apartment 25 feet long by 13 broad, and 10 high, which his host informed him had been cut in the space of thirty days by one single workman.

³ RAMSAY (*Hell. Studies*, x. p. 177) writes: "We enter the harem through the winding passage, H, and reach first the large women's sitting-room (A in his plan,

domestic dwelling until quite recently. During the Byzantine rule, the apartment D was apparently turned into a Christian chapel. The whole pile seems to have been inhabited by a Turkish agha, who rebuilt part of the walls with small stones and covered the

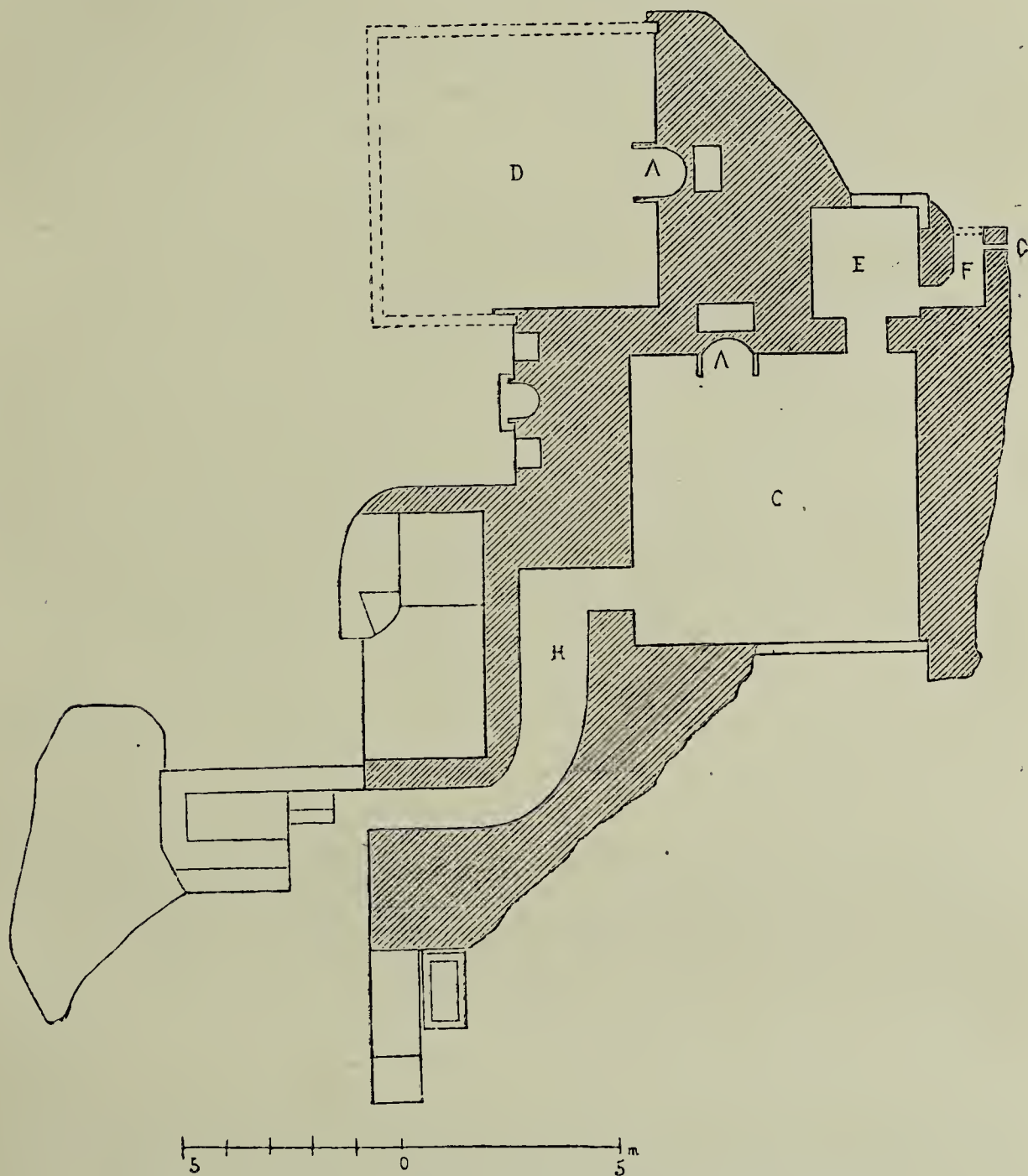

FIG. 46.—Plan of rock-cut dwelling, Kumbet. From Professor Ramsay.

whole with a coat of plaster. To him also should be ascribed the decoration over the mantelpieces, which Barth wrongly deemed

c in Fig. 46), then the little bedroom, B (E in Fig. 46), and finally the bath-room, D" (F in the above figure). M. Perrot also makes the larger northern room, D, of the *ἀνδρωντις* a Christian chapel; it is the smaller middle chamber below (marked E in Ramsay's plan) that has been used for that purpose.—TRS.

to be antique,¹ but the fireplaces cut in the living rock must be old Phrygian work, A.

It certainly is an interesting and somewhat rare phenomenon to find the mingling of the two styles of architecture thus employed simultaneously, the principle of which is so widely different ; the one using none but combustible materials, the other taking advantage of every salience in the earth's crust to excavate abodes for the dead and the living as well. The subterraneous house, as a rule, is only resorted to in localities where timber fails altogether, as in Egypt, but in especial in that Lycia whose sylvan scenes we shall ere long have occasion to visit,² where, too, the co-existence of the two modes led to curious results. In order to invest the façades of the hypogeia with monumental aspect, pieces of carpentry, mouldings akin to those cut in a wooden post, have been copied in stone. Shapes, therefore, which in the wooden house were organic members and formed an integral part of the construction, have been endowed with a purely decorative value. Nor are these the only items which have thus been turned from their natural use ; yet other instances of similar transpositions and adaptations are met with in this rock-cut architecture. From work done in the loom or with the needle, the Phrygian ornamentist likewise borrowed the designs which served to fill the field of his frontispieces so as to ensure variety of aspect.

The district in which occur the monuments whose main characteristics we have broadly sketched occupies but a narrow strip in Kiepert's excellent map. Eastward it follows the edge of a wooded tract, with Koutahia on the west, Seid el-Ghazi on the north, and Eski Hissar on the south. It corresponds to the ancient territory of two Phrygian towns of a certain importance, Nacoleia and Prymnessus, and is quite close to the first. We do not hear of Meros (which will be found near Kumbet on the map) until the time of the Eastern empire ; in the reign of Justinian it was a large borough with a bishopric. When we wrote our *History of Art*, no map of the canton had been published ; hence it was no easy matter to get a clear notion of the relative situation of the monuments from the verbal description of travellers. Professor Ramsay was good enough to place at my service drawings

¹ The miserable ornament and modern woodwork about the chimney was accepted as old by the German traveller BARTH (*Reise von Trapezunt*, etc., p. 95).

² *Hist. of Art*, tom. i. pp. 507-516 ; tom. v. book ix.

and observations taken on the spot, and afterwards to revise the topographical sketch made from them by M. Thuillier. Each tomb has been carefully numbered so as to enable the reader to determine approximately, at least, the place each occupies in the map (Fig. 47).

A first glance at the sketch reveals the fact that if the tumuli under notice are scattered all over the place, they nevertheless form two principal groups: one towards the north-east around the

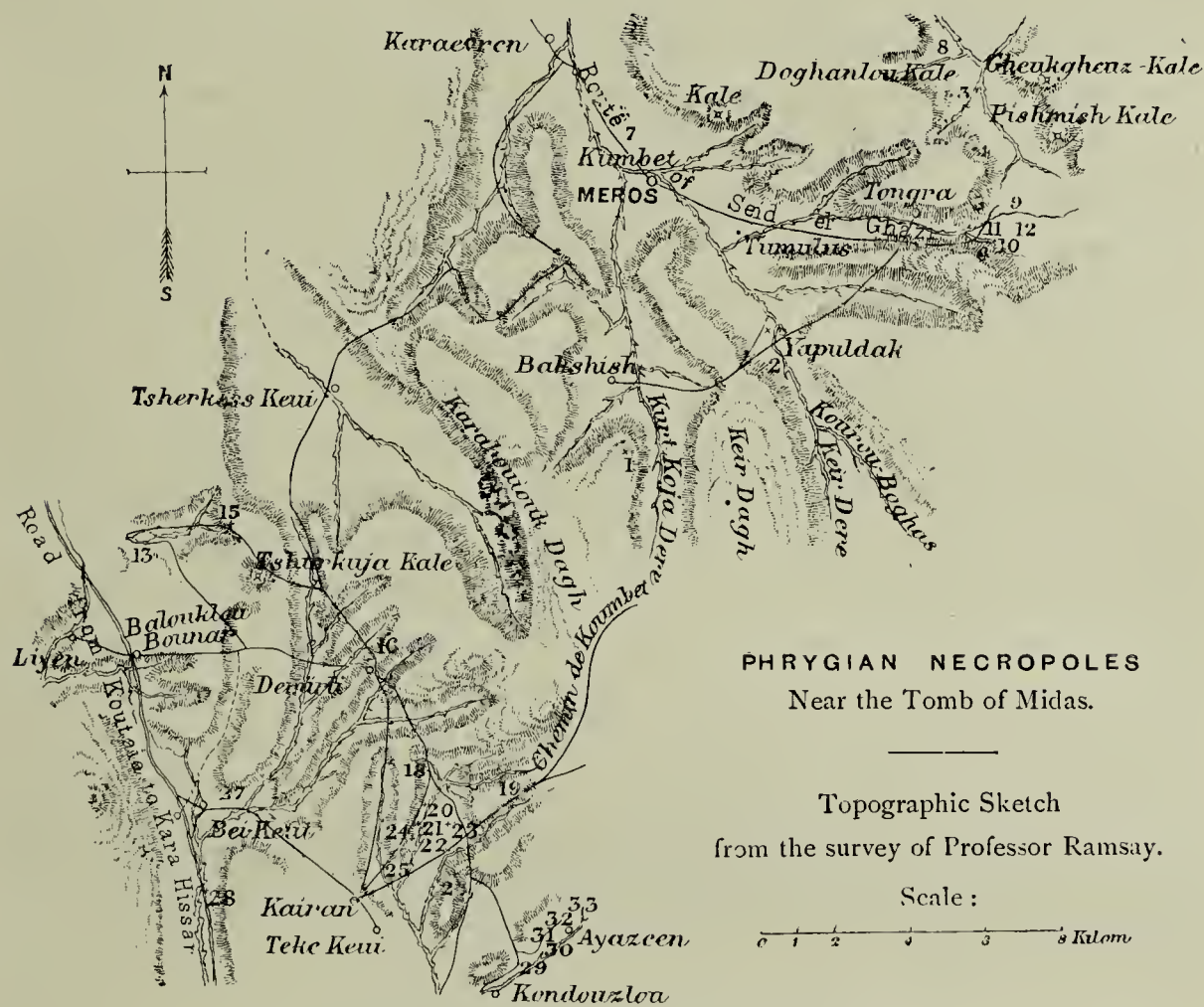

FIG. 47.—Phrygian necropolises. Topographic sketch.

Midas monument (9 in plan), and the other twenty miles to the south-west, near the village of Ayazeen. For convenience' sake, therefore, we shall follow Professor Ramsay and call them respectively the Midas necropolis and Ayazeen necropolis. The above appellation has no pretension to accuracy, and has no other merit than that of facilitating the finding of a particular tomb in either cemetery. The northern or Midas necropolis has been known since 1820, when it was visited by Leake, and subsequently by T  xier, Stewart, Barth, Mordtmann, and finally by me. That of

Ayazeen was discovered by Professor Ramsay, from whom we have borrowed all we have to say about the tombs it contains. If the tract rendered famous by monuments which reveal an art remarkable for originality has no geographical frontiers by which it can be easily traced on the map, the characteristics it offers are sufficiently marked and distinct to enable the observer to single it out from the adjacent country. It consists throughout of volcanic formations, more or less friable, which favour and seem to invite excavations. The works suggested by the nature of the rock, far from being everywhere uniform, exhibit wonderful variety, whence we may surmise that many generations had a hand in these hypogea. Nevertheless resemblances between those considered old, as against the comparatively modern, are sufficiently strong to warrant the conclusion that they were the outcome of one art—a national, or rather a local art—which in these secluded sylvan scenes was faithful to the forms and subjects it had started with. To these it clung with characteristic tenacity for generations, defending them against the seductive style and the nobler taste of the sons of Hellas. Nor is this all; the exceptional importance which attaches to these monuments lies in the fact that they manifest numerous instances of the use of an alphabet and idiom that have left no traces outside this region. As was suspected by travellers who first came across these lovely picturesque valleys, there is every reason for believing that such inscriptions represent the writing and the language of the Phrygians, a people who, had they not put their seal wherever their chisel was allowed to play on these rocks, would have seemed to belong to the domain of fable rather than of sober history.

FUNERAL ARCHITECTURE.

“The Phrygians,” wrote Nicholas of Damascus, “do not bury their priests, but set them up upon stones ten cubits high.”¹ No instance has been found in Phrygia in support of this assertion. Arguing from analogy, and assuming, as we are inclined to do, identity of blood between the tribes that founded the commonwealths on Sipylus and the banks of the Sangarius, what we should expect to find here would be burial-places in the form of tumuli. The type, as a matter of fact, cannot be said to be unrepresented in Mediterranean Phrygia; where numerous remains of artificial

¹ *Frag. Hist. Græc.*, Müller's edit., tom. iii.

mounds have been traced.¹ Professor Ramsay, in a letter to the *Athenæum*, dated December 27, 1884, thus describes the one specimen he was able to examine with some care: "The tumulus is bounded by a circle of square blocks, half imbedded in the ground, which have fallen from the top and sides of the mound. I was informed by a native that one of the stones had graven characters upon it, and with the help of four villagers, a pickaxe, and wooden poles to serve as levers, we succeeded in setting up the block, when it turned out that the signs were akin to the hieroglyphs of Cappadocia."² The tumulus in question is south of the village of Bey Keui, in the pass marked 28 in the map.

The finding of Hittite characters in the bowels of a tumulus might be taken as conclusive evidence that cognate monuments met with in Phrygia are anterior to the time when its inhabitants elaborated an alphabet which they derived from the Phœnician. However remarkable the discovery may be, it would be rash to advance an opinion from one solitary instance, and it is well to wait until the remaining mounds shall have been examined. We may regret that the explorations were allowed to stop here, and that no attempt was made to find out whether such mounds contain chambered graves. However that may be, the fact remains that, speaking generally, tumuli in Phrygia form the exception, not the rule. If the first owners of the soil, the Syro-Cappadocians, or, after them, the early bands of Phrygo immigrants who occupied the district, made use of this mode of sepulture, the habit did not last. All Phrygian tombs are hypogeia.

Of all the monuments in this district, the most famous is certainly that which since 1824 is known by archæologists under the name of the Midas tomb³ (Fig. 48, 9 in map). Its size,

¹ *Hell. Studies*, 1882, p. 18.

² RAMSAY, *Athenæum*, p. 884. It seems strange that the author should never have published the inscription.

³ Leake brought the monument to the knowledge of the world in 1800.—TRS.

See Professor Ramsay's observations in respect to our cuts, Figs. 48, 49. Whilst acknowledging that our general view of the Midas rock is far away the best that has been published, he still finds it inexact in some respects. The explanations he puts forward as to the character of the meander displayed on the Phrygian tombs are too long for reproduction, and we refer the reader to *Hell. Studies*, x. pp. 149-156. Here more than ever the need is felt of having the image as understood by Professor Ramsay placed side by side with that which he criticises. Knowing the sureness of hand and the pains taken by M. Guillaume when at work, we are loth to believe his drawing faulty, as affirmed by Professor Ramsay.

the singularity of its ornamentation, the mythical name of "Midas" written on the façade, its situation at the head of the valley amidst picturesque rocks fringed with gloomy firs, have all helped to bring it out from among the rank and file surrounding it, which are either lost in the depths of plantations or buried out of sight in the clefts of the rock, a small aperture on the apex and an insignificant rude front being alone visible. The royal monument, on the other hand, has no trees to take from the proportions of its fine frontage (which starts from the ground, giving it an amplitude not to be seen anywhere else) and stupendous base of rock, 7 or 8 m. high; nothing, in fact, diverts the eye of the beholder from Iasili Kaïa (the Great Written Stone), as the native woodmen style it. Like a magnet, it has attracted and attracts every traveller who has visited or visits these parts; it is the first he wishes to see, and when he leaves it for a while, it is only that he may return to it. He makes it his head-quarters, the better to examine it.

Our visit was in 1861. Solicitous as we were to push on to Ancyra, where a long and important work awaited us, we made all the same arrangements to spend the night in a neighbouring tomb, so as to devote another day to the monuments of the Midas necropolis. But Fate willed it otherwise; this time in the guise of a heavy storm of rain and wind, which broke out during the night and did so much damage to our photographing apparatus, that it was rendered useless for the time. As the Midas plateau was not down in our programme, we did not feel justified in wasting the time requisite to take measurements, and make hand-sketches and photographs with a light camera of the tombs it contains. Reluctantly, therefore, and with heavy hearts, we set our faces towards our real goal, followed by the regret of not being able to tarry here for one week at least, so as to take exact measurements of the principal tombs, which even now have not yet been acquired to archæology. Five and twenty years have gone by, and the sequel of the *History of Art* takes me back to these very woodlands and picturesque rocks, that I may properly characterize and define the style and processes of Phrygian art from the remains it has left behind. Once again in my essayal approximately to date and classify the tombs met with in this region, the Midas rock, better than any other, will serve as starting-point and term of comparison for tombs, the oldest of which may perhaps go

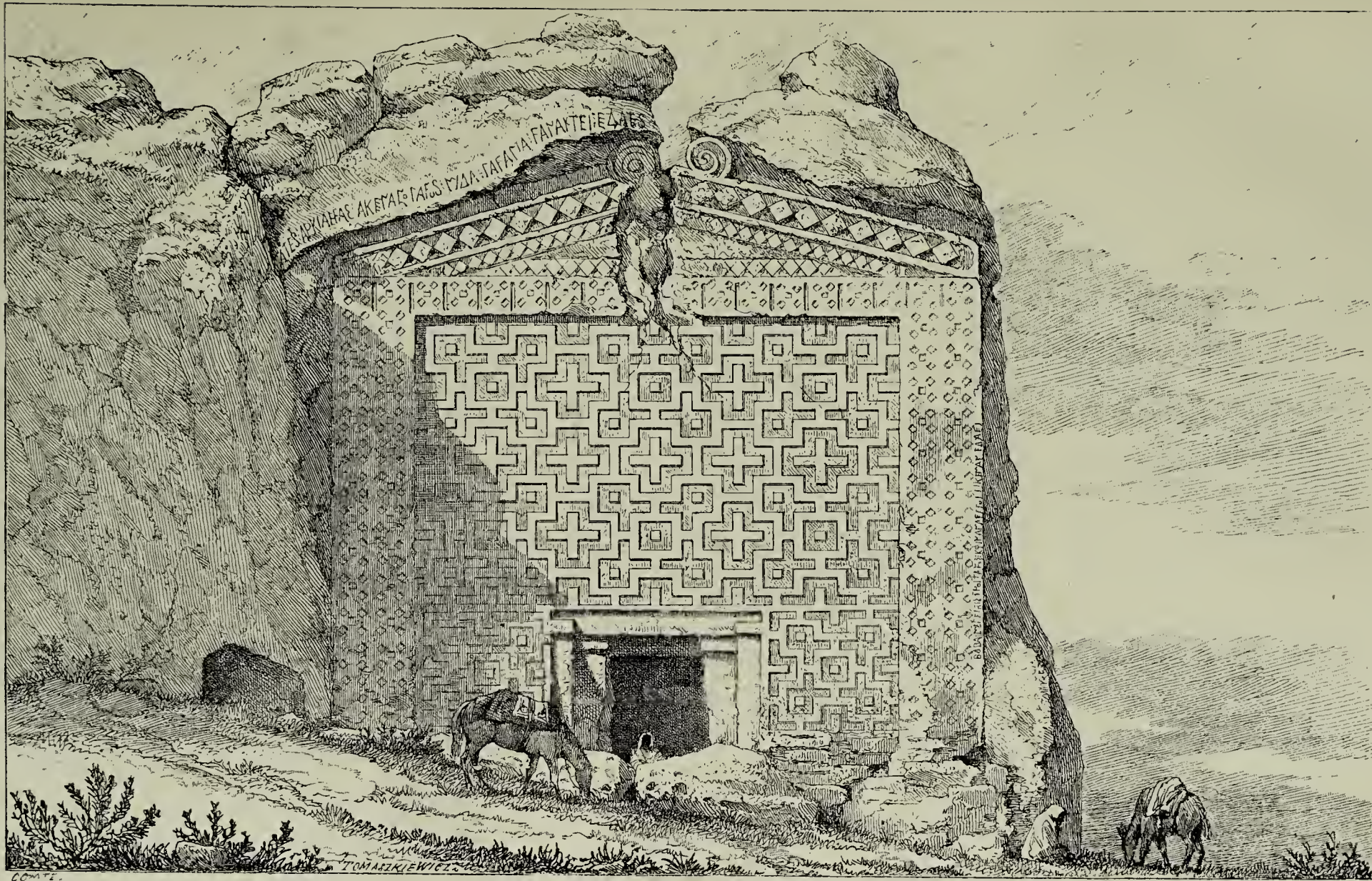

FIG. 48.—Monument of Midas.

back to the eighth century B.C., whilst the more recent may be coeval with Alexander and his immediate successors.

The monument deserving of this high place of honour may be described as a sculptured frontispiece cut in the face of a vertical wall of tufa 20 m. high, bounded on one side by an immense chasm where the road passes, and on the other by rocky masses which close the ravine called Doghanlou Deresi (Hawk Valley). It is a rectangular table, 11 m. 74 c. by 12 m. 50 c., separated from the rough portions of the rock by a shallow groove, the crowning member being a very low triangular pediment. A device composed of a double volute, the centre of which has disappeared, appears above the tympanum. The remaining parts, including the ornament and the inscriptions, are in a marvellous state of preservation. The lettering on the left describes an oblique line on the virgin rock, almost parallel to the slope of the frontal; that to the right runs from top to bottom in a vertical line on the outer edge of the upright. Finally, pierced in the face of the slab, is a false door or niche, framed by triple jambs with a slight inward slope, and in retreat one from the other, the effect of which is to deepen and narrow the opening towards the top—a contrivance taken up again by the builders of the Romanesque and Gothic style of architecture. The second lintel or architrave rests upon rectangular saliences or bracket-like shapes (Fig. 49).¹

If from the main and more striking lines we pass on to details, we shall find that the façade is wholly covered with geometrical forms, either graven or in relief, be it on the flat pilasters, the horizontal fascia, under the coping of the roof, and even the field of the tympanum. A star-like pattern, composed of four lozenges whose centre is marked by a smaller lozenge, surrounds the frontispiece. Under the gable are, first a row of squares of larger calibre, then other two rows of smaller ones, placed edge-wise so

¹ We have intentionally had the false door drawn on a larger scale than the rest of the monument, because it was inadequately figured in T'exier's book, and from him reproduced in many works. The plate in question, however, is on the whole better than the vast majority to be found in his volume, and has but two inexactitudes: one is his having placed the vertical inscription on the virgin rock, when it should be on the outer edge of the jamb; whilst his shadows are all too strong, giving a depth to the niche which it does not possess in reality. Again, there never was here a funereal bed, as shown in his sketch; whilst the meander pattern right and left of the door widely differs from that traced by his pencil.

as to form what is technically called the saw device. The greater intricacy of the main design is more apparent than real, in that its elements are wholly rectilinear. It is a continuous meander, forming and limiting spaces of varying size and shape, which are occupied by rows of crosses and small elongated dots. The form, meanders and crosses have a relief of 13 c., and occupy the inner slab, which, as already stated, is 11 m. 74 c. in height, by 12 m. 55 c. in width.¹ We do not vouch for the absolute accuracy of

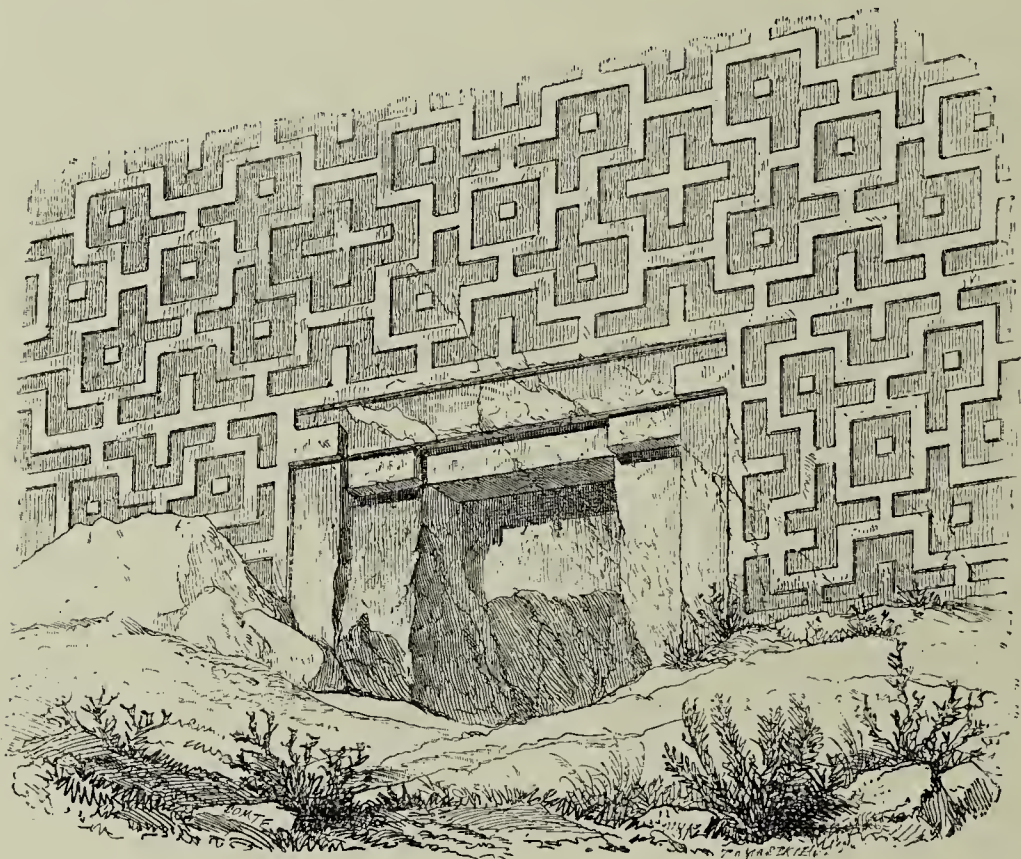

FIG. 49.—Monument of Midas. False door. Drawn by E. Guillaume.
Exploration archéologique, Plate VI.

measurements we had no time to verify; but they cannot be far removed from reality.

To the left of the façade, on the level, appears a small grotto roughly cut, 1 m. 60 c. wide, 75 c. deep, one side of which is 1 m. 35 c. and the other 1 m. 82 c. high. Over it is incised an inscription in large Phrygian letters, 30 c. high and 1 c. deep,

¹ Our figures are taken from TÉXIER, *Description*, tom. i. p. 154. A sketch of Sir C. Wilson, kindly forwarded to me by Professor Ramsay, gives the following measurements:—Width of sculptured slab, including pilasters, 16 m. 62 c.; width of surface occupied by meander, 12 m. 39 c.; height of the same, 12 m. 16 c. (the figure is obviously too high, for Sir Charles's sketch shows a greater difference between breadth and height than appears from his measurements); mean width of pilasters (they are not quite alike), 2 m. 13 c.; height of the whole, 21 m.

and, like those on the frontispiece, should be read from left to right. This is not the place for attempting to unravel the meaning of these texts; nevertheless, regard should be had to the uppermost and longer inscription graven on the native rock (Fig. 1), as likely to be helpful in determining the nature of the monument itself. The prominent place it occupies, its length of line (13 m.), the size and clearness of the characters, each separated by a dot, so as to make confusion impossible; finally, the issues involved in these alphabetical signs;—everything combines to attract the eye and draw attention to it. Transliterated in Roman figures, it reads thus: “*Ates arkaie Fais akenanola Fos midai la Faltei Fanaktei edaes.*”

It is self-evident that the first word is the nominative singular of the radical *atu, attu*, the great Phrygian god, the Atys, whom classical writers represent as the inseparable companion of Cybele. The name seems to have enjoyed popular favour, for Herodotus (i. 34) tells us that a son of Cræsus and an old king of Lydia (i. 71) were so called; and Strabo writes that it was the official title of the high priest of Cybele at Pessinus.¹ Discarding the next two words of doubtful reading, we come to the dative form of the familiar name of Midas; those which follow, *la Faltei* and *Fanaktei*, being in the same case, are supposed to be his honorific or patronymic appellations. Curiously enough, if we drop the initial letter F of the second word—instances of which may be observed in cognate languages—we have the Greek dative *ἀνακτι, ἀνακτει*, from *ἀναξ*, prince. *Edaes*, on the other hand, is the third person of a verb, which in Phrygian probably represented an Indo-European root, signifying to establish—in Sanscrit *da-dha-mi*, to establish; Greek, *τί-θε-μι*; German, *stellen, stabilire, établir, poser*.² Hence the words known at present yield the following formula: “Atys . . . dedicated . . . to king Midas” (*Ἄτης . . . Μίδα . . . ἀνακτι . . . ἔθηκεν*).³

¹ *Hist. of Art*, tom. iv. p. 659, n.

² G. CURTIUS, *Grundzüge der Griechischen*, etc., 3rd edit., 1869, p. 238, No. 309.

³ For more details respecting the conjectures that may be adduced about the words still undeciphered, and the reasons for considering *edaes* as a third person of an aorist, see RAMSAY, *Hist. Relat. of Phrygia and Cappadocia*, pp. 29, 30. Professor Ramsay persists in considering the Midas monument as a funereal memorial, whilst we would rather attribute to it a commemorative and religious character (*Journal*, x. pp. 149–156). No grave-chamber has been found at Iasili Kaïa, nor in one or two cognate façades, and until a discovery which would settle the question is made,

Philologists who have studied the Phrygian texts, and every traveller who since Leake has visited the district, are agreed in accepting the testimony borne by the inscription, to the effect that this important work was executed in honour of king Midas. On the other hand, opinions are divided as to whether we are confronted by a real tomb, in which were formerly deposited the mortal remains of the prince, or a mere cenotaph, a commemorative monument, the use of which was to keep green the memory of a mythic ancestor, an eponym hero, the founder of the monarchy worshipped as a god.

The idea that rises uppermost from the contemplation of the monument is naturally that of a sepulture, whilst the rank of the illustrious dead buried in it would account for the abnormal size and decoration of the façade; but if a tomb, where is the funereal chamber? Texier, one of the early explorers of the Phrygian necropolis, was at first inclined to see in the cavity formed by the false door, a niche in which the body was deposited, and formerly closed by a covering slab (Fig. 49). On maturer reflection, however, he seems to have abandoned the notion, closer inspection having shown him that a recess 84 c. in capacity would ill accommodate the corpse.¹ We may add that if the body was placed, or rather squeezed, in the niche under discussion, a slab, of necessity very thin, with joints manifest to all, would have been the only safeguard against violation, and would have invited rather than repelled the vulgar curiosity and rapaciousness of subsequent generations. Lastly, had there been a stone to disguise the hollow, the surrounding rock would show the marks left by the covering slab; but nothing of the kind occurs, nor is there the slightest indication of any mode of sealing having been here. And against any lurking doubts, we may adduce a false door in

we feel justified in upholding our hypothesis whilst fully conscious of the difficulties which beset it. Then, too, I very much doubt if the small niche to the left-hand side of the monument, even enlarged as Professor Ramsay has it in Fig. 16, could ever have been a royal tomb, inasmuch as it is level with the ground and would have been too easily entered. Professor Ramsay (p. 186) states that in one inscription of the Midas rock there occurs a Phrygian word which may signify *grave-chamber*. The decision as to whether *sikeneman* presents the degree of probability which he attributes to it must be left to philologists.

¹ Téxier, after describing the Midas monument and other two near it, goes on to say, "Could it be possible to regard the central niche of the former as having served as chambered grave, nothing of the sort can be deduced from the latter" (*Description*, tom. i. pp. 154-158).

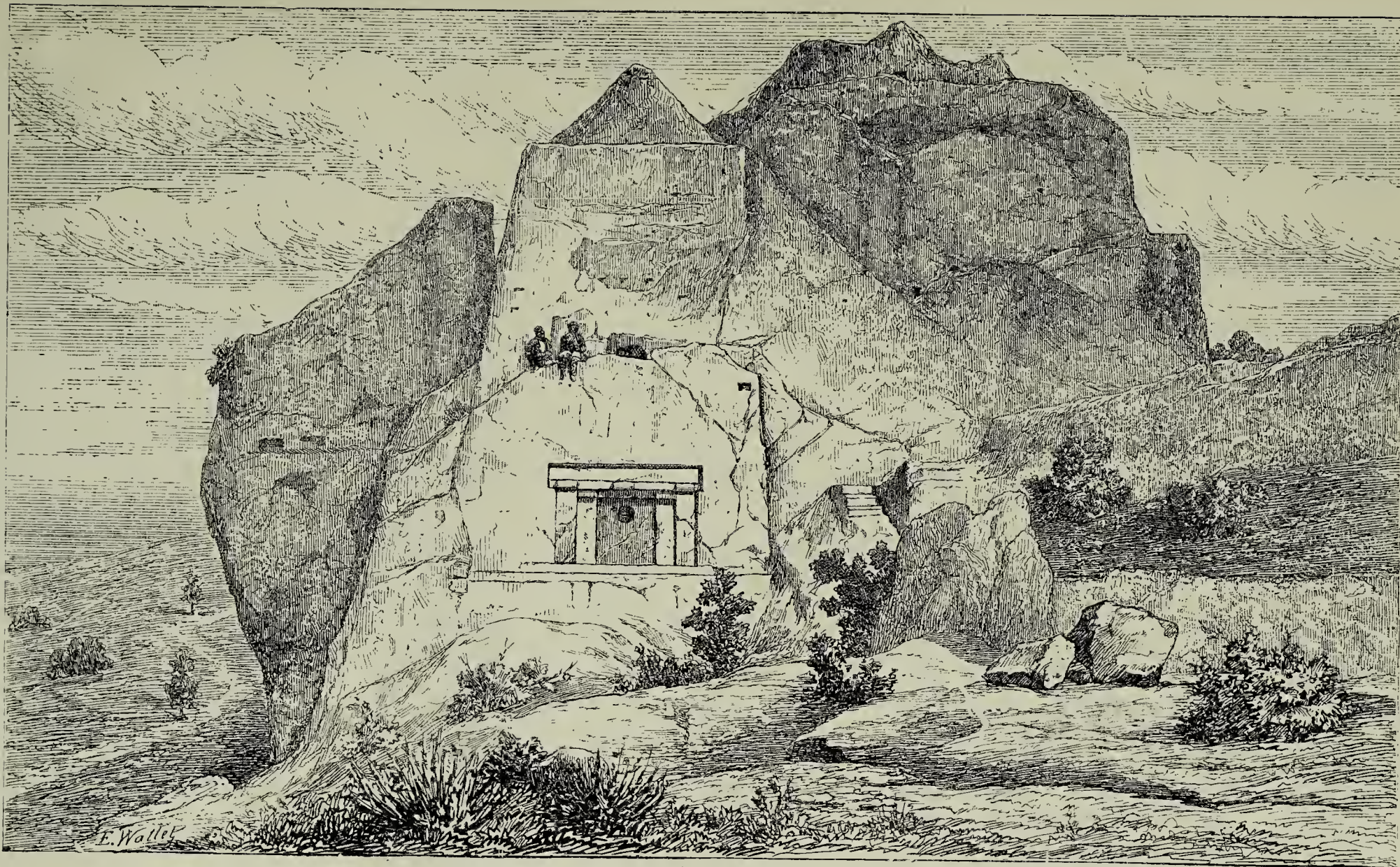

FIG. 50.—Delikli Tach. Perspective view. Drawn by E. Guillaume. *Exploration archéologique*, Plate V.

which precisely the same arrangement is reproduced; it is found in a façade, which certainly belongs to the art and the people who created the Midas monument. It is the most westward specimen of Phrygian activity. As an advanced post, it rises alone of its kind on the slopes of Mysian Olympus, close to Harmanjik, in the middle valley of the Rhyndacus, and is called by the natives Delikli Tach (Holed Stone) (Fig. 50). On the information yielded by a

passage of one of our predecessors we repaired thither, that we might observe it with the care it deserves.¹ We will describe it in this place, as helpful to understand in what light one is tempted to view the Midas monument, when obliged to abandon the notion of the niche being a funeral chamber.

Delikli Tach stands towards the extremity of a rocky ridge twisted into the most fantastic shapes. The

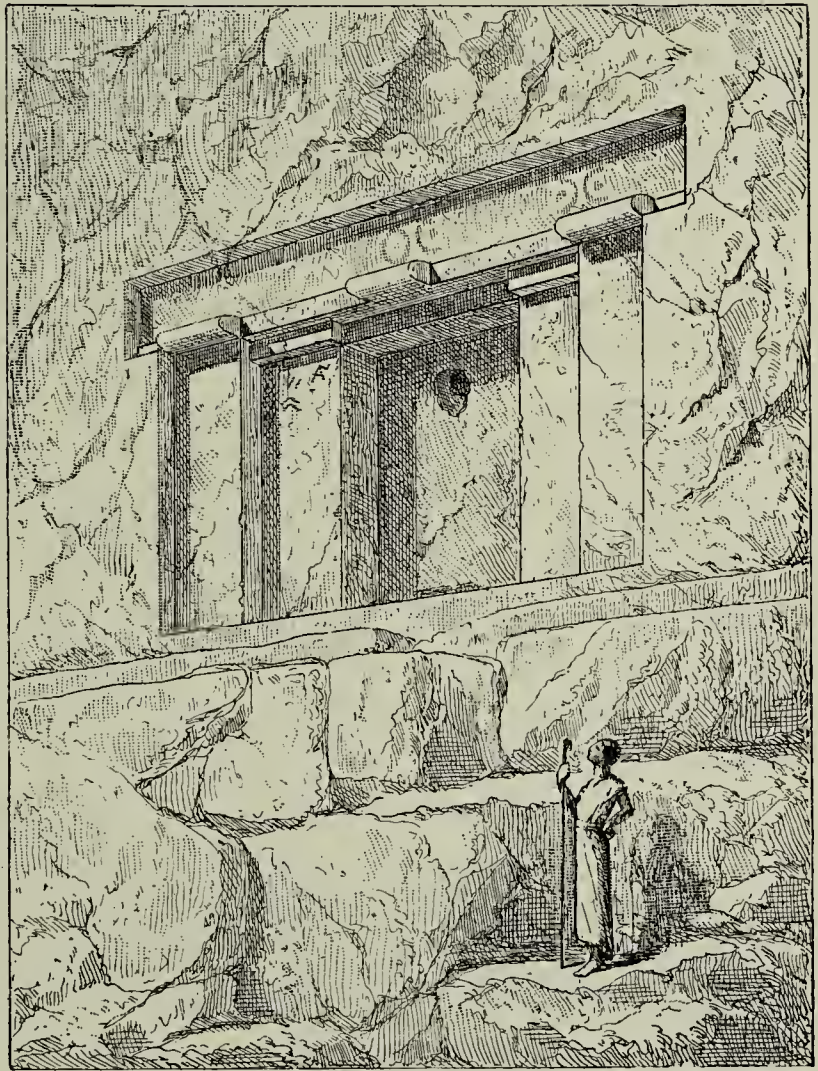

FIG. 51.—Delikli Tach. Detail of doorway. Drawn by E. Guillaume. *Explor. arché.*, Plate VI.

thick mass advances like a promontory into a narrow gorge, at the bottom of which flows one of the many small affluents of the Rhyndacus. Its position over the path (probably an old road) which runs from Harmanjik to Mohimül, and the almost white colour of the cliff in which it is excavated, cause it to be seen at some distance. The broad massive rock has been rent into three unequal parts, with jagged outline of varying depth. The two

¹ *Recherches*, tom. i. p. 97. In Hamilton's book the Phrygian tomb is described in ten lines, and represented by one simple sketch.

masses on the right and left have not been touched by the chisel, and preserve their uneven and natural saliences. But the central fragment was cut in such a way until a façade-like aspect was obtained, terminating in a very pointed pediment. A false door, preceded by three steps, enframed in wide double posts, appears in the middle of the façade, at about one-third of the whole height of the rock (Fig. 51). The effect of the whole is satisfactory. The marriage of simple architectural shapes with the virgin portions of the rock is exceedingly happy; we find here united the picturesque rugged outlines of nature, with the human interest supplied by a work of art, and the latter, as an index of the mind that created it, never fails to excite our curiosity and call forth our sympathies.

The circular opening seen in the pseudo-door is certainly a late, perhaps a modern degradation, made by treasure-seekers to enable them to penetrate into the inner chamber, which they supposed to exist behind. The irregular cutting of the narrow aperture is enough to prove that it did not form part of the original plan, but was hastily pierced to the size of a dormer-window to allow a child to get in, when, being disappointed in their object, they suspended their operations. But for this, however, the real and only entrance, near the summit of the rock, would not have been suspected. Now, anybody by putting his head through the aperture can see the well into which the body was lowered, as it was conveyed to its last abode. The grave where the body was laid was no more than the bottom of the well or chimney, 4 m. 30 c. high, opening towards the middle of the vertical façade. Reference to our perspective section, through transverse axis (Fig. 52), shows that, as soon as the dead was placed in his stony bed, the mouth of the well was sealed down with care by two stout slabs, the marks of which—60 c. apart—may still be seen. Their arrangement and the salience of the upper stone over the one below are indicated by dotted lines in plan (Fig. 53). As the walls of the well would not be seen, little care was bestowed on their appearance and effect, so that they were left almost in the rough; the builders being content to invest the sepulchre with the utmost solidity, so as to guard it against unwelcome visitors and profanation. As at Iasili Kaïa, here also the false door is furnished with a double case; the second or inner being set back from the first. The general arrangement is identical, and the differences are

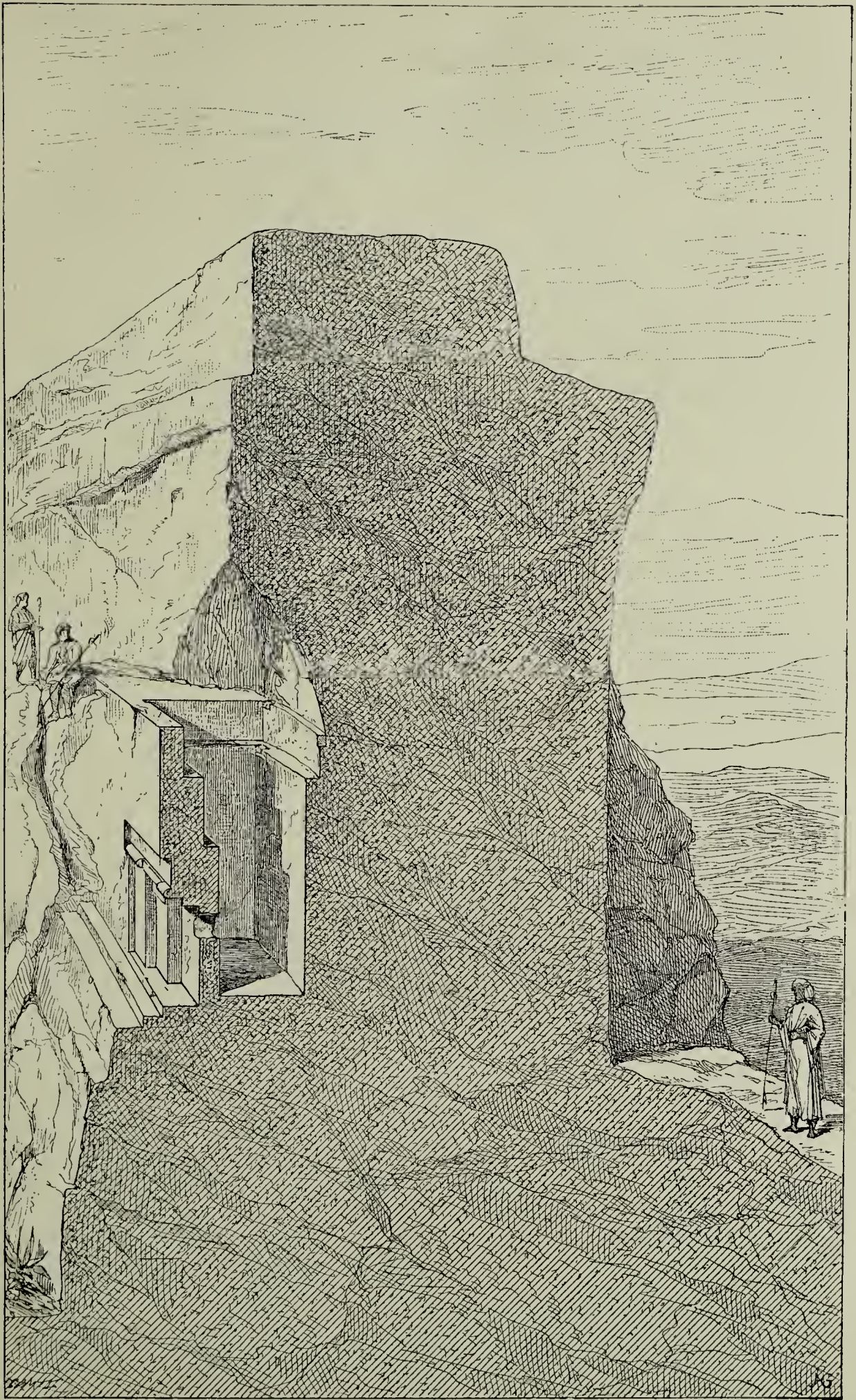

FIG. 52.—Delikli Tach. Perspective section through transverse axis. Drawn by C. Chipiez.

reducible to two. Thus, at Delikli Tach, upon the second

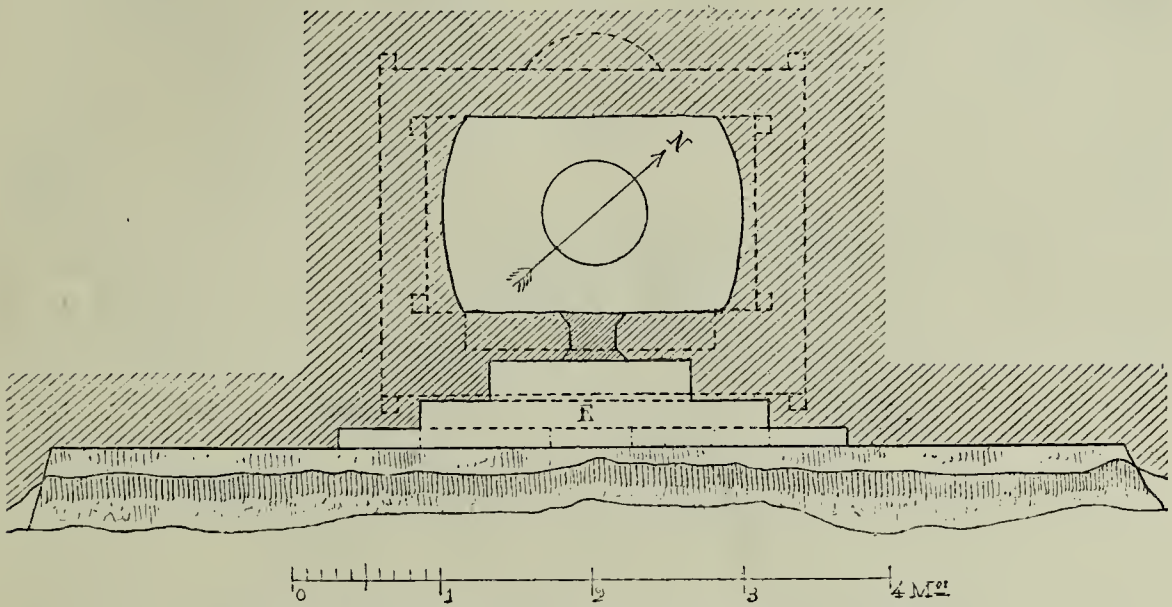

FIG. 53.—Delikli Tach. Plan of tomb. Drawn by E. Guillaume.

lintel, which projects far out beyond the jambs and forms a kind of ancone (Figs. 54, 55), are three large intermitted tores.¹ The adjustment at Iasili Kaia was simpler, and exhibits neither tores nor ancones. Then, too, no trace of painted ornament has been found about the Midas monument, nor in the tombs around it. At Delikli Tach, on the other hand, many portions of the rock still exhibit stuccoed patches, white, black, and red. The latter colour in especial abounds on the vertical face of lintel, F, and soffit, E (Fig. 54). Lintel and soffit—and, owing

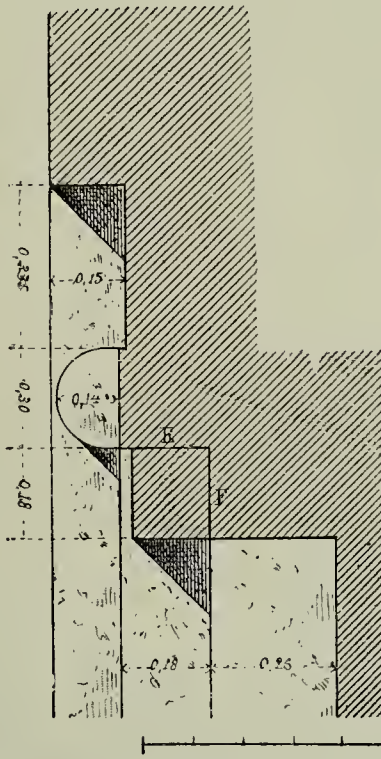

FIG. 54.—Delikli Tach. Profile of lintel on inner jamb. By E. Guillaume. *Explor. arché.*, Plate VI.

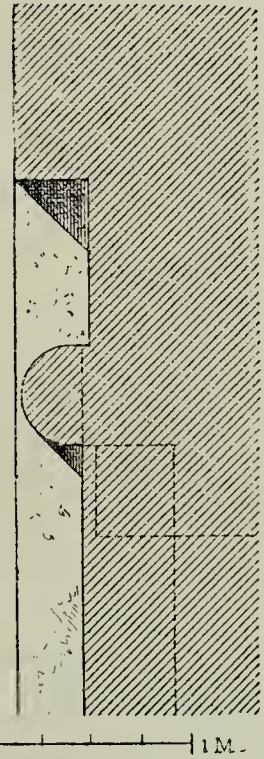

FIG. 55.—Delikli Tach. Profile of lintel on external jamb. By E. Guillaume. *Explor. arché.*, Plate VI.

to its sheltered position, notably the latter—still preserve remnants of a scroll painted white on black—at least, so it looked to us—with red in the middle, which occupied the whole length (Fig. 56)

¹ In Fig. 51 the left tore has disappeared, but has been restored in our illustration.

of the stone. Applied ornament seems also to have been resorted to in the decoration of this façade; for between the small circular niche which appears above the mouth of the well and the commencement of the frontal are holes which are far too regular not

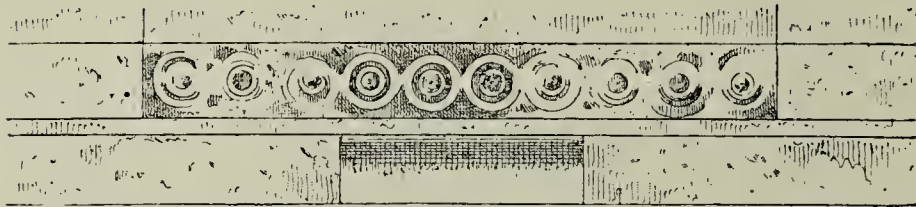

FIG. 56.—Delikli Tach. Tinted scroll on soffit. E. Guillaume. *Explor. arché.*, Plate VI.

to be artificial. They suggest the notion of having served to fix metal plates.

A good many niche-like hollows, seemingly artificial, look out of the rocks surrounding Delikli Tach. They are so ruinous, however, that plans and measurements are out of the question; nor is it possible to advance an opinion as to their original purpose. Here and there may also be traced remains of other cuttings. Thus, for instance, our general view



FIG. 57.—Delikli Tach. Characters incised on jamb of door. *Explor. arché.*, Plate VI.

and there may also be traced remains of other cuttings. Thus, for instance, our general view (Fig. 50) exhibits steps

which formerly led to the top of the rocky mass, in the depth of which the tomb was hollowed. We found no vestige whatever in the neighbourhood to mark the existence of a town which had here its necropolis. Nothing was gained by our study of the ground at this particular spot, and very little is to be hoped from two single letters—all that remains of an inscription, apparently very short, incised on the inner jamb of the false door on the left-hand side. Bits of colour still adhere in the hollow of the letters, which are reproduced, one-fifth of their actual size, in our illustration from an impression taken from the stone (Fig. 57).

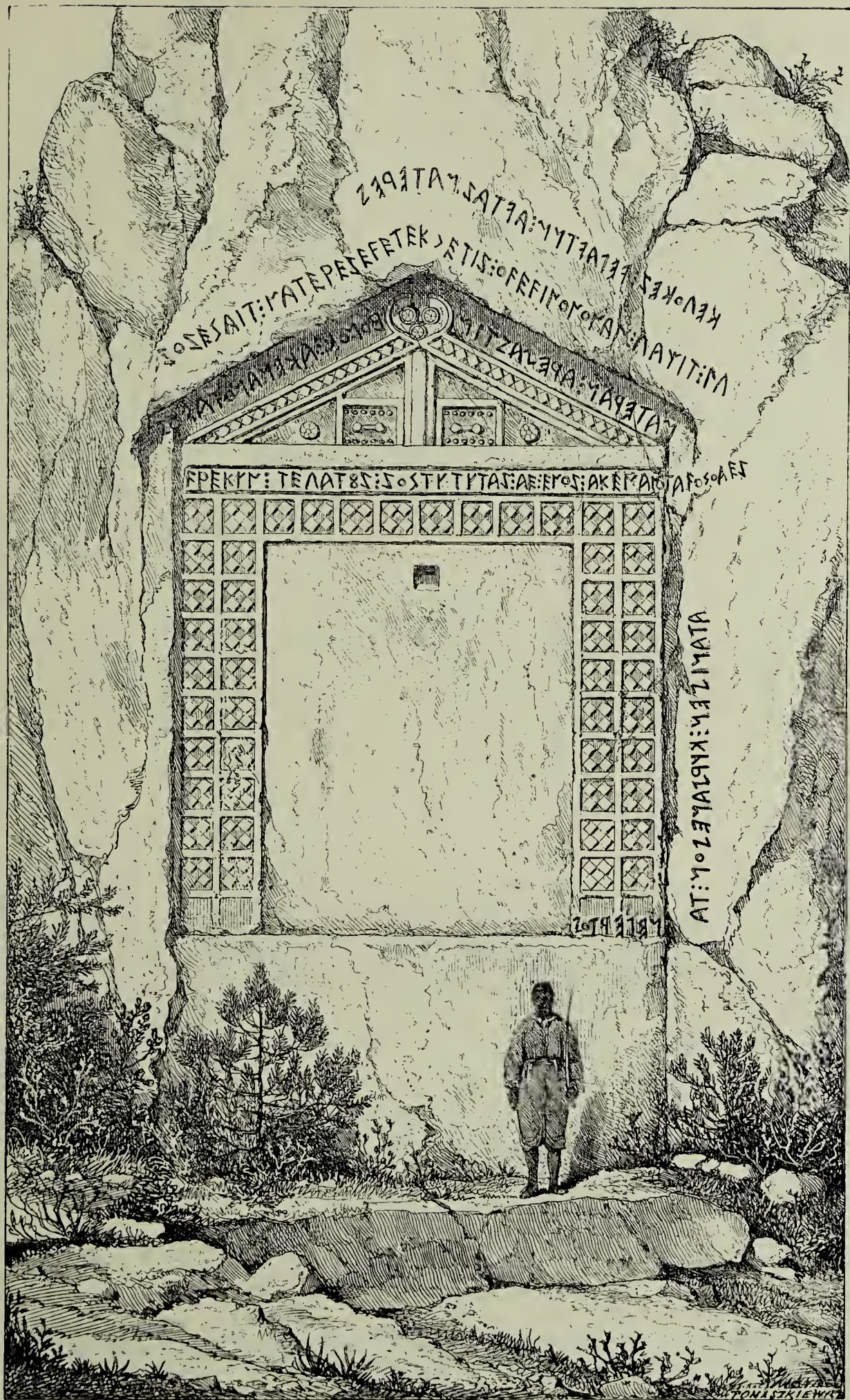

FIG. 58.—Rock-cut façade.

If *per se* these two letters have no meaning whatever, they are valuable and of great interest in that they permit us to formulate a probable conjecture in regard to the relative age of the two monuments we have juxtaposed. They are not found in the alphabet which the Phrygians borrowed from Greece, instances of which are given in our cut representing inscriptions met with on the rocks around Nacoleia (Fig. 2). On the other hand, they have been identified in a somewhat more complicated form—one on a fusaïole from Hissarlik; and the other, composed of two sets of parallel lines, both on fusaïoles, a clay patera brought out of a tomb at Thymbra within the Troad, and in Cypriote inscriptions.¹

The deduction to be drawn from the coincidence is the following. The two characters under discussion belonged to one of the many varieties of the alphabet we called Asianic, which, by way of reduction and simplification, was derived like the syllabary of Cyprus, where the older form persisted longer, from Hittite hieroglyphs, which obtained throughout Asia Minor before the introduction of Phœnician letters. Agreeably with this hypothesis, the Delikli Tach tomb would have been excavated before the Phrygians received from the Ionian Greeks the alphabet they made use of at Iasili Kaïa and the sepulchres surrounding it, and, as a natural consequence, it is older than the tombs in the neighbourhood of Nacoleia.

Our supposition is in accord with the character of the monument and its close resemblance with the Midas rock. In both there is great contrast between the rude massive rocks enframing the façade and the frontal surmounting it, whilst their shapes and architectural members exhibit intelligent proportion and symmetry. The only difference is that at Delikli Tach all was regulated on simple lines; little or no effort was made to heighten the effect of the pediment and inner slab by ornament, which, like rich drapery, covers the whole façade at Iasili Kaïa. We may be permitted, therefore, to consider Delikli Tach as the first exemplar of a type invented by the Phrygians, a type they improved and perfected in the upper valley of the Sangarius, where they had their political and religious centre for a period of two or three centuries.

¹ PERROT, *Explor. Arché.*, p. 107. Sayce, appendix written for Dr. Schliemann's English edition of *Ilios*. We have shown in another place that the letter on the right is not a double one, the repetition of the lines being purely ornamental; the ligatures belong to the decadence of a system of writing, and not to its initial period.

During our expedition in Asia Minor, we went straight from Delikli Tach to Iasili Kaïa, where the striking family likeness observable between the two monuments was brought home to my companion, M. Guillaume, and myself, with perhaps greater force than if a longer interval had interposed between one journey and another. Arguing from exterior analogies, we judged that they might extend to the interior. But we did not for a moment deem it possible that the sinking or false door could ever have been a grave. We were inclined to think that there was behind it a real mortuary chamber, entered by a shaft as at Delikli Tach. The next thing was to find the entrance, which we were disposed to seek at the summit of the rock, behind the broken finial crowning the pediment.¹ One of our party, M. Delbet, volunteered to climb up the rock, so as to test the truth of our hypothesis; but his attempts were unsuccessful, and as we could not spare the time it would have taken to procure ladders, ropes, and so forth for the purpose, we were fain to abandon the undertaking.² Professor Ramsay, with true British tenacity of purpose and British elasticity of limb, succeeded in scaling the rocky wall, "whose top is so narrow that he could sit on the edge as on the back of a horse, pushing himself along with his hands." But he found no sign of an orifice to the well he was in quest of. He had, however, ample opportunity for observing that "as the stone is a soft conglomerate, a deep chimney of this kind would split it like a wedge."

If the notion that the Midas rock is a tomb be persisted in, there is no other alternative but to seek the grave towards the foot of the rock; or, rather, our only chance of discovering the entrance to the mortuary chamber is to clear away the silt and potsherds that have gathered in front of the façade to the height of three or four metres. The spade alone can clinch the question. On the other hand, no instance of such an arrangement can be adduced in the whole Phrygian necropolis. Hence the question we have asked before may be asked again, as to whether we are confronted by a real sepulchre, or a simple commemorative monument, whose imposing dimensions, elaborate and skilful workmanship, are witnesses to the homage rendered by the princes of the eighth or seventh century B.C. to the eponym hero, the legendary ancestor,

¹ *Explor. Arché.*, pp. 105, 106.

² RAMSAY, *The Rock Necropolis of Phrygia (Journal, 1882, pp. 16, 17).*

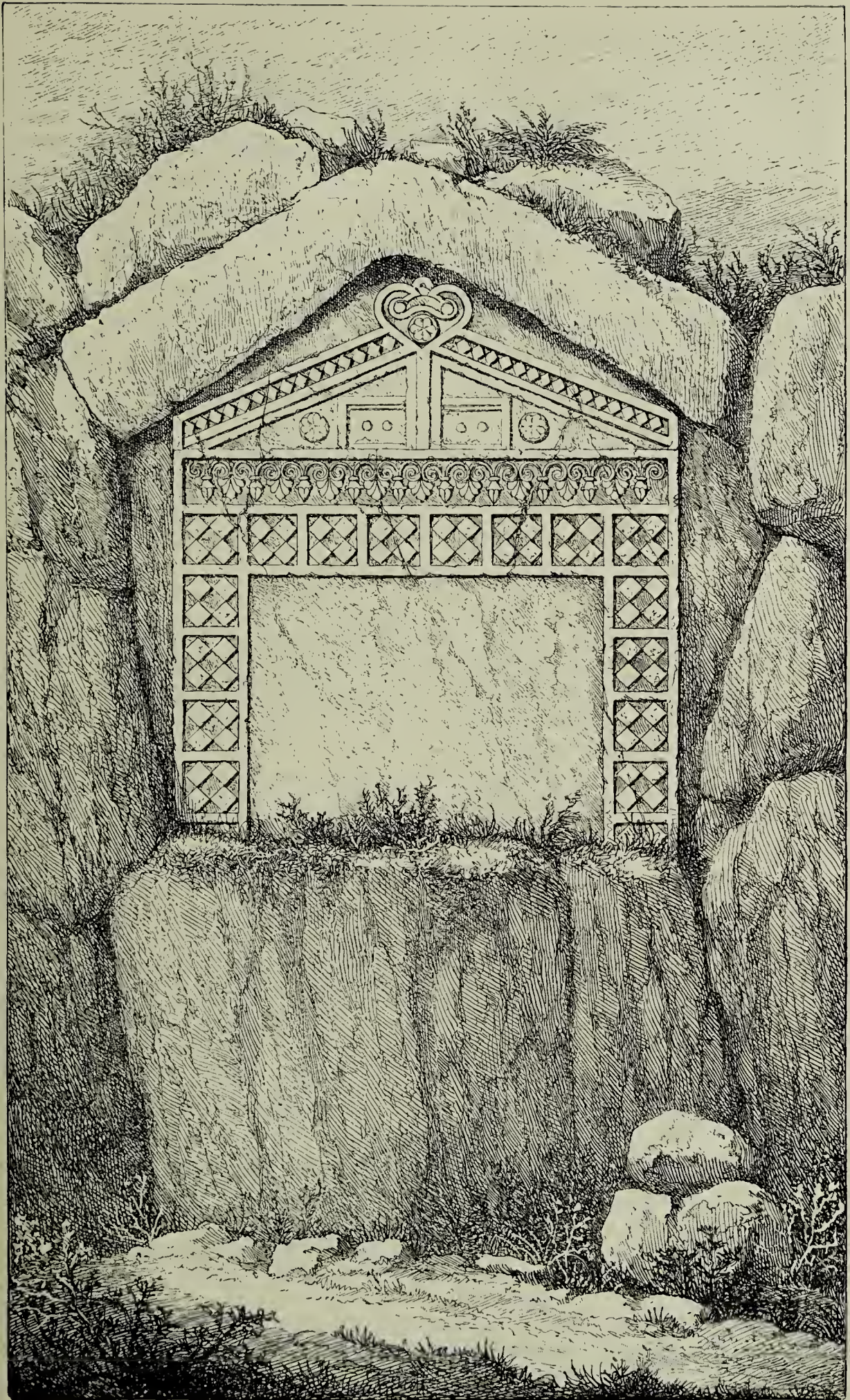

FIG. 59.—Rock-cut façade.

whose name they adopted and to whom they paid divine honours.¹ Viewed in this light, the niche to the left was a shrine in which lamps and offerings were deposited as tokens of regard to the ancestral god.²

What tends to confirm our conjecture is the fact that in the same neighbourhood are other two sculptured frontispieces, whose tops, covered by a fine growth of pines, can be easily reached; but where, despite diligent search, no well, nor the semblance of a pseudo-door, have been detected.

The most important, because of its inscription—the longest known in Phrygia—is Fig. 58 (4 in plan). It consists of no less than five lines, three of which follow the slope of the roof below and above it on the native rock. Then a horizontal line appears on the frontal in the place usually occupied by the frieze in a Greek entablature, ending on the dexter hand on the rough stone; whilst

¹ We plead guilty to having misquoted Hesychius. The error arose from our having, contrary to our invariable custom, taken the lines from a book which happened to be close at hand, where the misprint occurred, and not from the original as we should have done. They should be read as follows:—Οἱ ὑπὸ Μίδα βασιλευθέντες ἐσέβοντο, καὶ ὄμνον τὸν Μίδα θεόν, ἣν τίνες μητέρα αὐτοῦ ἔκτε τίμεσα λεγουσεν. As may be observed, "Mida" is in the genitive case, whilst θεόν is in the accusative, and agrees with the feminine article τὴν; hence the construction is, "The goddess of Midas," doubtless Cybele, who was said to be the mother of the great ancestor of the Phrygians. Even in this form the passage may be adduced in favour of the opinion I put forth: Midas, whose name so largely figures in national legends as the son of a goddess, came to be considered in the light of a heroic or semi-divine character.

² Of the inexactitudes complained of by M. Ramsay, I find but one of any relevancy (*Hell. Studies*, x. pp. 161-163). It occurs on the left side, which should have been left incomplete, whilst we have left out a few squares which occur on the right side. (See *Ibid.*, ix. Fig. 13.) The fact is that the ornament of the façade was never finished; we forgot to warn our draughtsman, and when the mistake was discovered it was too late to be remedied. M. Ramsay makes a great deal of our having distributed six nails on each of the double doors of the pediment, when one panel should have but four. In truth, a venial error. We might with far better reason reproach him with having produced, in 1888, a picture which shows no trace of the characteristic sinking which surrounds the façade, and imparts thereto a niche-like aspect; upon which he vehemently insists in 1889. This our illustration, albeit containing two wee nails in excess, brings out very distinctly.

The slight discrepancy between the text and the translation in regard to the tombs of the Ayazeen necropolis and the Midas city is due to the fact that I have written this part with the help of the additions and corrections at the end, so as to save the reader trouble and put him at once in possession of the whole evidence.—

the last forms a vertical line outside the right-hand upright. If, on the one hand, the text, out of which the words "Materee" and "Materan" are alone understood, occupies a larger space, on the other hand the decorative scheme is conceived on simpler lines than at Iasili Kaia. The frame, made up of square posts surrounding a field carefully smoothed over, but quite plain, is the only portion which has been carved. Towards the top of the inner slab, a tiny square niche has been pierced, which seems to belong to the

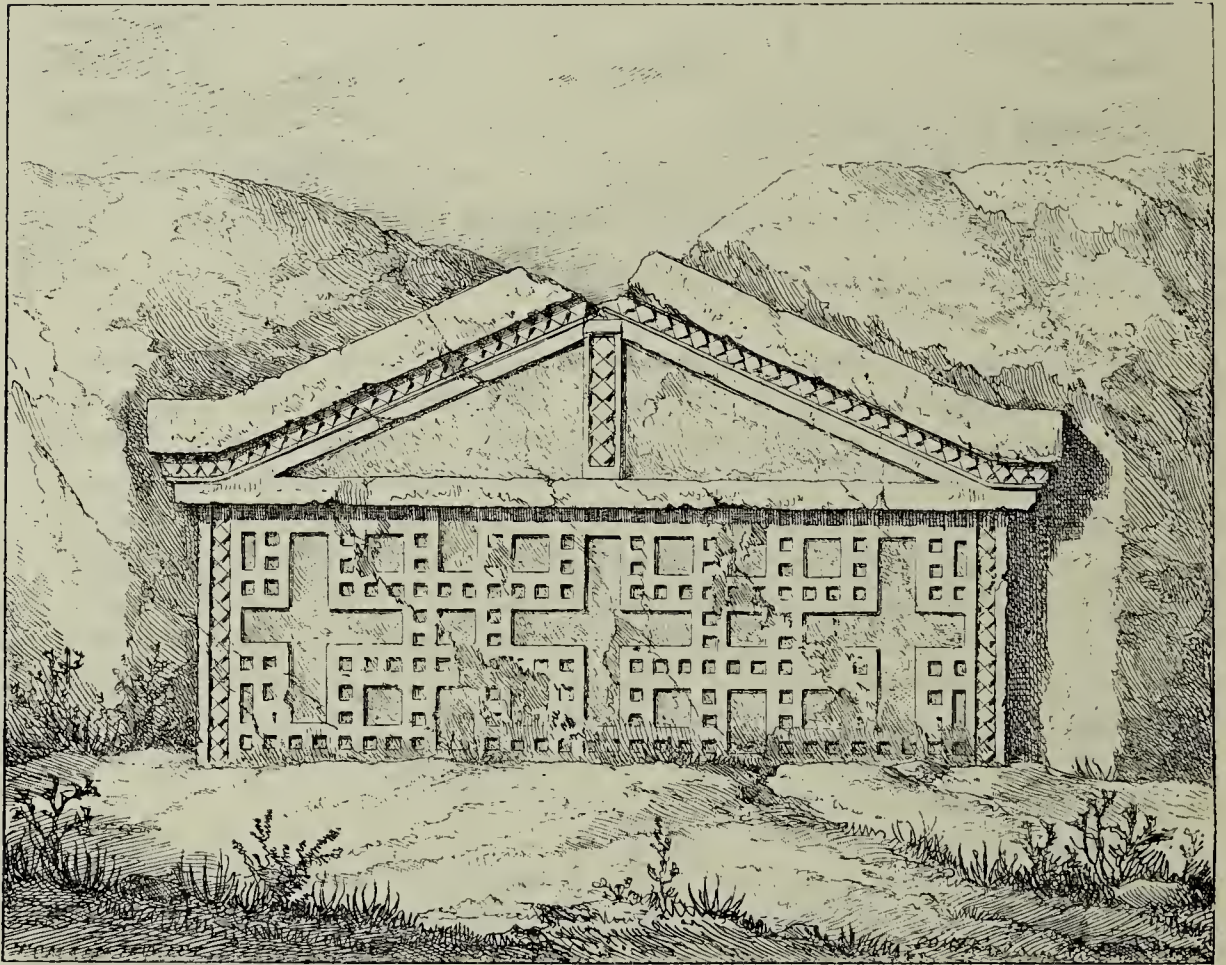

FIG. 60.—Tomb in the Ayazeen necropolis. *Journal*, Plate XXI.

primitive plan. Other niches, circular in plan and elevation, are seen above and to the left of the pediment.

The presence of the long inscription well agrees with the character we are inclined to ascribe to this façade. We own to feeling some degree of hesitancy in respect to Fig. 59 (5 in plan), which exhibits no inscription on its front, no chambered grave in its rear. In general plan, however, it is identical with Fig. 58; whilst on the rock which serves as foundation to the inwrought façade appear small niches and stone benches which seem to imply

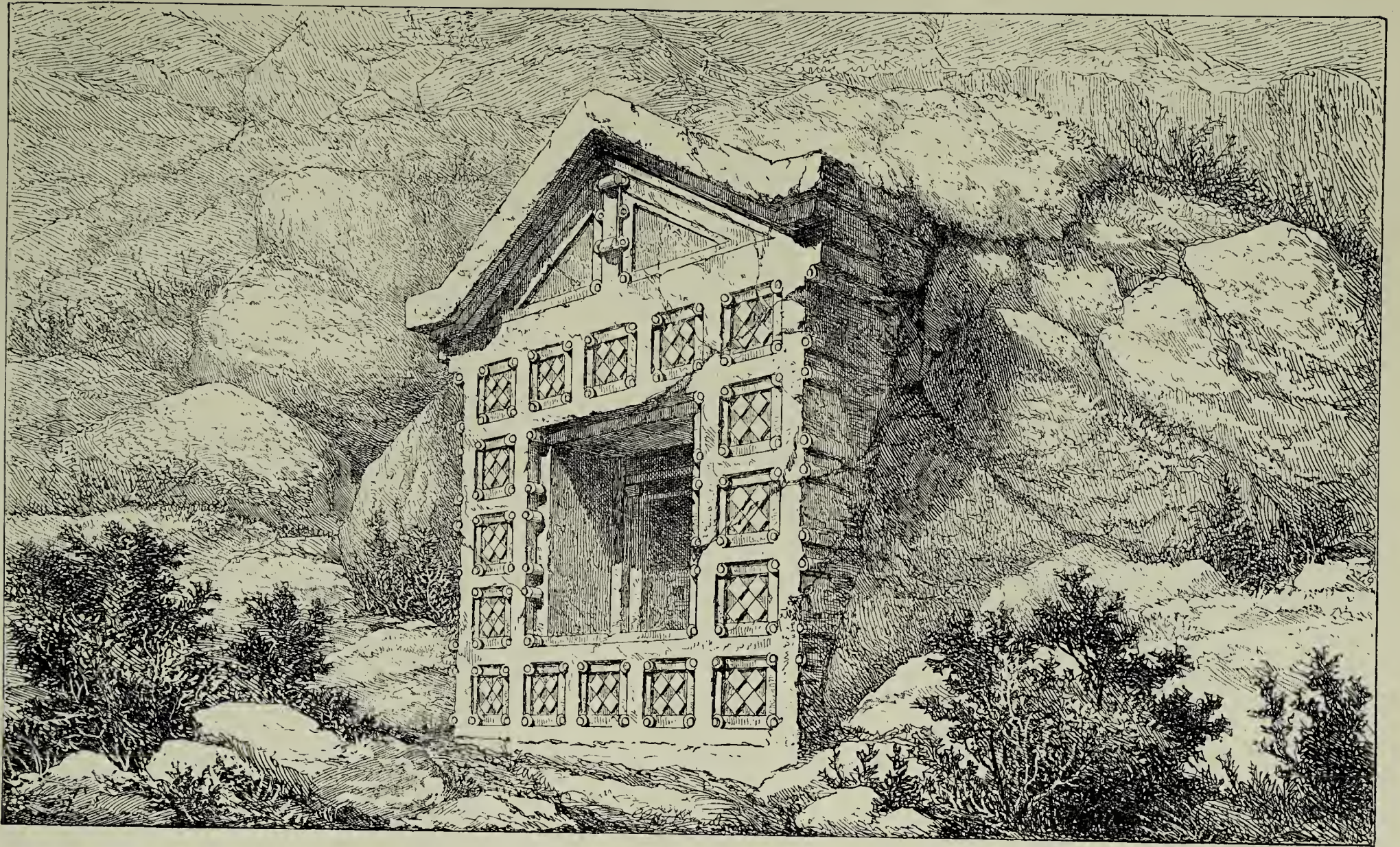

FIG. 61.—Rock-cut façade. Perspective view.

that the site was much frequented.¹ All the same, it does not help us to explain how a people in possession of a system of writing should have laboriously cut out of the solid rock a commemorative monument, which was to perpetuate the memory of a god or royal personage, without taking the trouble to record his name. Here more than ever are explorations needed around, above, and at the base of the rock, one of whose faces bears as elegant and well adjusted a decoration as was ever executed by the Phrygian chisel. Had this been a tomb, the absence of a Phrygian text should cause no surprise; since, with one notable exception, instances abound with chambered graves, troughs or stone beds, that leave no doubt as to their sepulchral character, which yet are innocent of any literary document.

The number of monuments respecting which it is impossible to pronounce a decided opinion is reducible to three or four. Real tombs, on the other

hand, may be counted by hundreds; but as they are pretty much alike, a sequent description would involve wearisome iteration, and would only result in loss of time. We propose, therefore, to single out such ex-

emplars as will serve as types for the many. The grave of a certain number of these is entered, as at Delikli Tach, by a

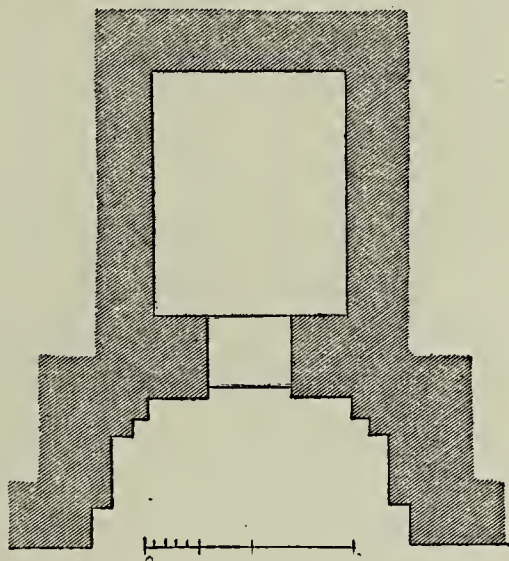

FIG. 62.—Plan of tomb at Bakshish.
After Wilson.

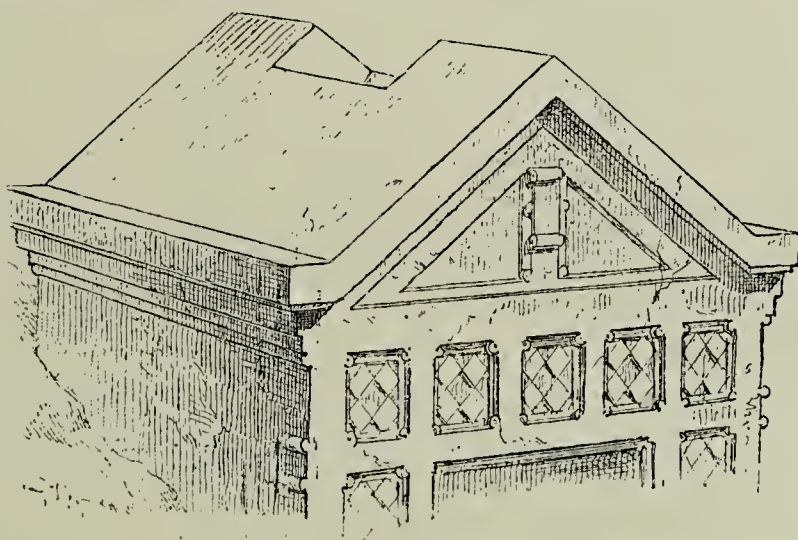

FIG. 63.—Tomb showing mouth of well. After Ramsay.

¹ TÉXIER, *Description*, tom. i. p. 157, Plate LVIII.; Stewart, Plates IX., X.; BARTH, *Reise von Trapezunt*, p. 92. We have corrected Téxier's drawing with the aid of sketches handed to us by Professor Ramsay; hence it has been possible to represent more exactly the rosettes and the central acroterion.

perpendicular shaft; in most, however, the opening is in the centre of the façade.

For obvious reasons we are unable to dwell at length upon the tombs around Nacoleia, because the information to hand is far from being as minute and complete as that derived from our notes in regard to Delikli Tach. Professor Ramsay has made no plans of them, and confines himself to the general statement that the tombs in the great necropolis of Ayazeen offer a close analogy to the Midas monument.¹ The only one he describes is Fig. 60 (24 in plan), whose sculptured front is akin to the royal memorial, save that it has no false door. It is locally known as Maltash, the stone of the treasure. About 45 c. behind the frontispiece an oblong shaft, 4 or 5 m. deep, was cut down into the rock, in the floor of which appears a rectangular grave, now exposed and distinctly seen from above. The covering slab was probably removed by treasure-seekers when they broke the top of the pediment; the shallow groove, however, into which the stone fitted, is visible to the present day in the sides of the rock.

We are a little better off respecting a beautiful tomb south of Bakshish² (1 in plan). From the data furnished by the various travellers who have visited it, we have been able to evolve the general view³ (Fig. 61), plan (Fig. 62) and sketch (Fig. 63). The latter shows the groove for the covering slab on the apex of the monument and the situation of the chimney.

The most remarkable specimens of memorials of this class, from a decorative standpoint, are found about three miles northward of Ayazeen, with entrance to the grave in the centre of the façade, as that of a house. The lion, which in Pteria is figured about the city and palace portals, or as support to the throne, watches here over the last abode of prince and grandee. The device seems to have found great favour in funereal architecture. The tomb in which

¹ *Studies*, p. 17.

² The rock bears a Phrygian inscription, but so much worn as to have been undetected on Professor Ramsay's first visit, when the sketches we reproduce were made.

³ Stewart, Plate VII. The general view was drawn, under the supervision of M. Chipiez, from original sketches made on the spot by MM. Wilson and Ramsay, including a photograph taken by the latter during a recent visit. The lower part of the façade is much worn, and the geometrical forms hopelessly obliterated by the influence of the weather. At the extreme eastern point of the Midas plateau is another tomb of the same general type as that at Bakshish. It is cut freer from the rock, except the back, which is engaged. The roof slopes on either side (*Journal*, x. p. 166, Fig. 19).

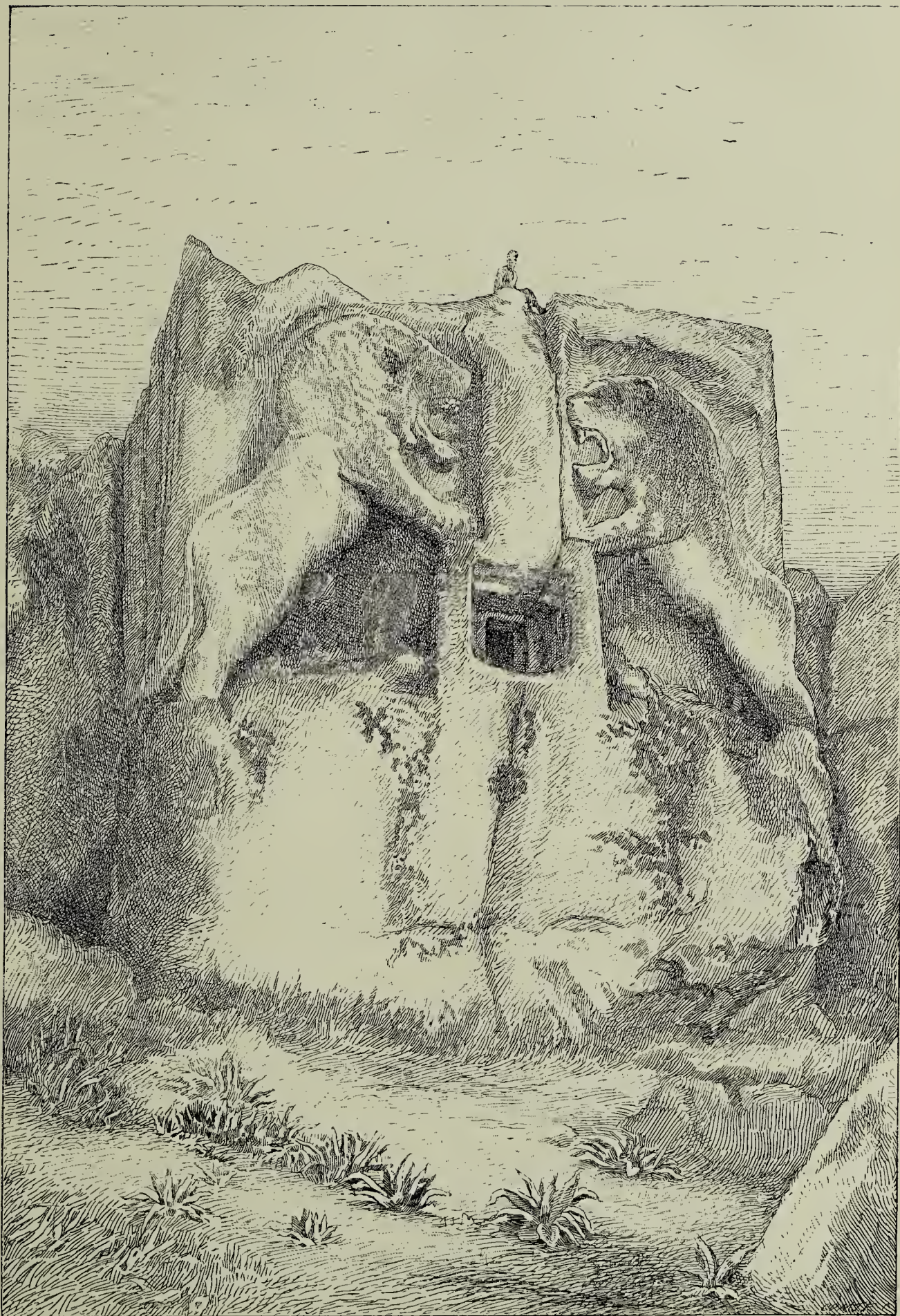

FIG. 64.—Tomb in the Ayazeen necropolis.

it is seen to the best advantage belongs to the group under notice, where the rocks, without being hard, are firmer than about Ayazeen. Hence in the perpendicular faces of the cliffs, which hem in the plateau on all sides, have been pierced chambered graves with gaping mouths, so high up as to require ladders and other contrivances to reach them. An immense rock, jutting from the plateau above, has been rudely fashioned into a parallelepiped block, wholly void of mouldings; a plain small doorway appears in the usual position, 6 m. above the ground (Fig. 64, 21 in plan). Over the lintel of this door is carved a slightly conical obelisk, topped by a capital, the outline of which brings to mind that of the echinus in the Doric capital. It is flanked by rampant lions, one on each side, their fore-paws resting on the door-posts in threatening attitude and mouth wide open, as though to warn off the sacrilegious from the tomb. Beneath each of the lions is a little cub, kept in deep shadow by the larger figures, in more senses than one; the heads of the latter are almost level with the top of the slab, and monopolize the whole attention.¹ The chamber is small, archaic, and of no interest.

Professor Ramsay states that there are eight other tombs at least in this necropolis, whose façades are enriched by the lion device; some of them, however, belong to a very late period.

Had it been preserved, the finest and perhaps the oldest specimen of sepulchral decoration yielded by the lion device would be found in a hypogee, some 90 m. beyond that which we have just examined (22 in map). But, unfortunately, water and Plutonic agency have broken it to pieces. The site it once occupied is covered with immense blocks six and eight metres long, and of proportionate thickness. Huge fragments are scattered or piled up on the ground in picturesque confusion (Fig. 65).

The fragments in question excited the curiosity of Professor Ramsay, who since then returned to the spot in 1884 and 1887, bent upon unravelling the history these stones had to tell. He went

¹ M. Blunt's photograph, from which St. Elme Gautier drew Fig. 64, was taken late in the day, when the whole monument was in deep shadow; hence he failed to bring out the cubs. They were given more prominence in Plate XVII., *Journal of Hell. Studies*. The shape of our pilaster does not agree in every respect with the verbal description of Professor Ramsay, written in consequence of a second visit to the monument (*Athenæum*, December 27, 1884, p. 864). The fact that the adult animals are without mane, coupled with the presence of two cubs, leads to the conclusion that the sculptor intended to represent lionesses (*Journal*, ix. pp. 368, 369).

to work lever in hand, "turning about the less heavy blocks, slipping in between those that could not be moved, sinking trenches around others, so as to examine the lower face of fragments touching the ground." The result of his investigations is as follows:—

Like the tomb decorated with a pair of lions, this, too, was

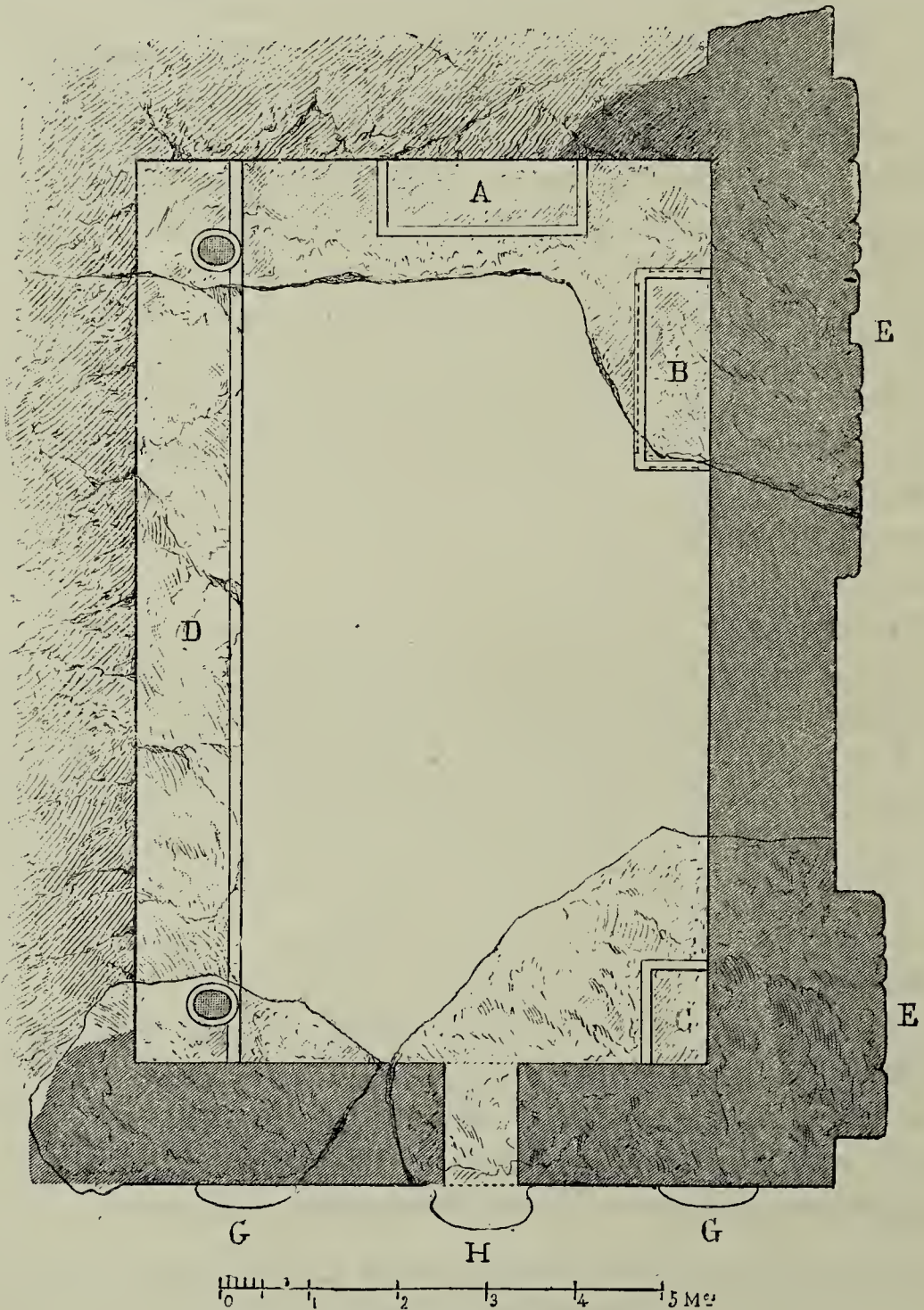

FIG. 66.—The Broken Tomb. Restored plan.

hollowed in the face of a projecting cliff, along with grave-chambers of less importance, of which two sides at least, west and north, were disengaged. The door was in the north side (Fig. 66). The south wall of the hypogee, which formed the end or back



FIG. 65.—The Broken Tomb. Drawn by St. Elme Gautier from Blunt's photograph.

wall of the chamber, is almost unimpaired, for it was cut in the solid mass of the hill. Thus the width of the apartment, 6 m. 29 c. by 3 m. in height, is obtained, as well as the shape of the roof, which had a double slope, a king-post as support to the side rafters like carpentry work.

The same arrangement was repeated in the north face, save that the door appears in the position occupied on the opposite side by the bed (Fig. 67). A funereal couch is hollowed in the back wall of the grave-chamber (Fig. 68).

In the north-west side of this appears a seat, whilst a second mortuary bed occupies its west face (Fig. 69). Between it and the settee there occurs a gap. A passage, 1 m. 6 c. by 1 m. 21 c., ran along the eastern side; two columns at least, one at either end, supported its roof; that in the back wall is still in position, whilst the fragment, now lying on the ground, which formed the north-east angle, shows the marks left by the upper part of the second pillar (Fig. 70).

The base of these supports is a large torus; above the shaft, a palm of elegant design expands on the inner side of the column, facing the interior of the chamber, of which a perspective view is given (Fig. 71). The two funereal beds, the settee, portico, and sculptured faces, are witnesses that a more complicated arrangement

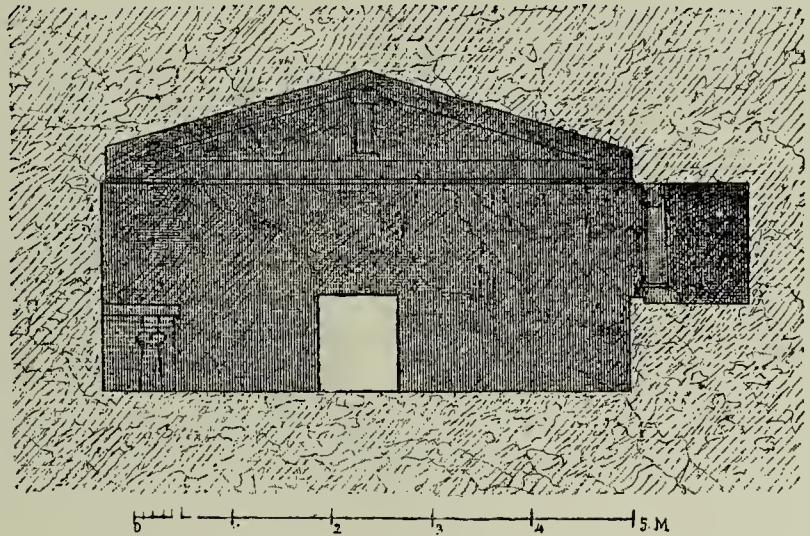

FIG. 67.—The Broken Tomb. Restored transverse section through the north face.

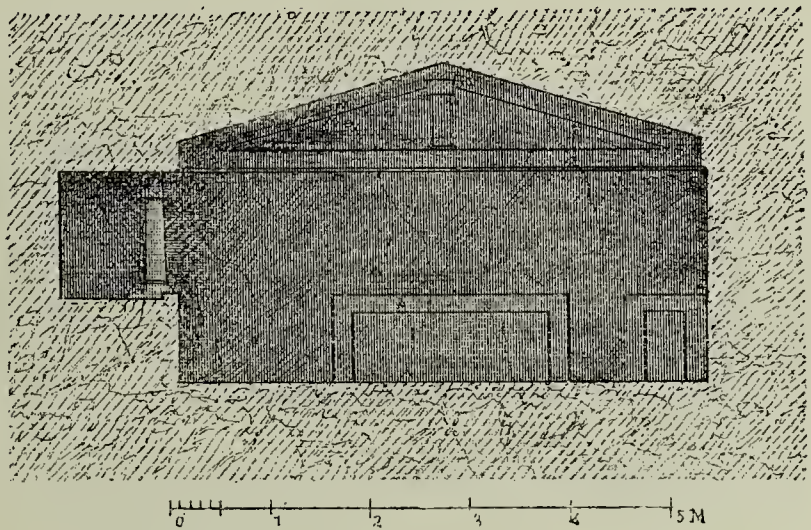

FIG. 68.—The Broken Tomb. Transverse section through end wall of vault.

and monumental aspect were aimed at in this tomb, the like of which has not yet been met with in the Phrygian necropolis. The exterior decoration was equally ambitious.¹

Both sides freed from the mass were carved. No less than three lions, cut in very high relief, adorned the western face; two

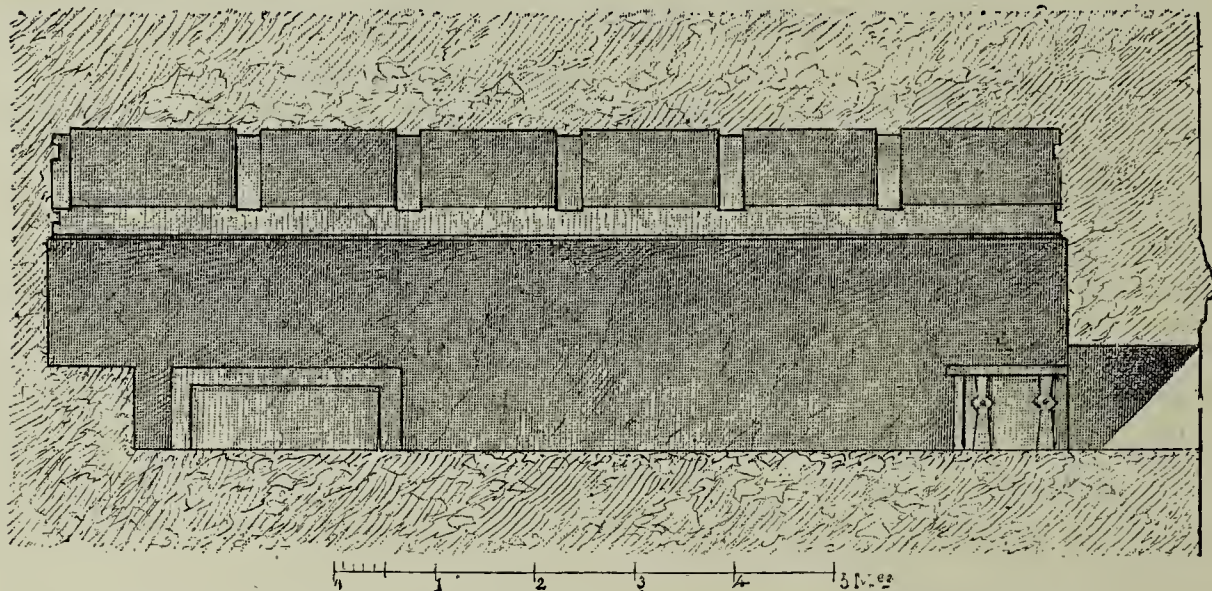

FIG. 69.—The Broken Tomb. Restored longitudinal section through west face.

stood rampant, with their raised fore-paws pressed against each other (Fig. 66, E; Fig. 122). The action of the animals has been made out from their fore-paws, which were discovered still

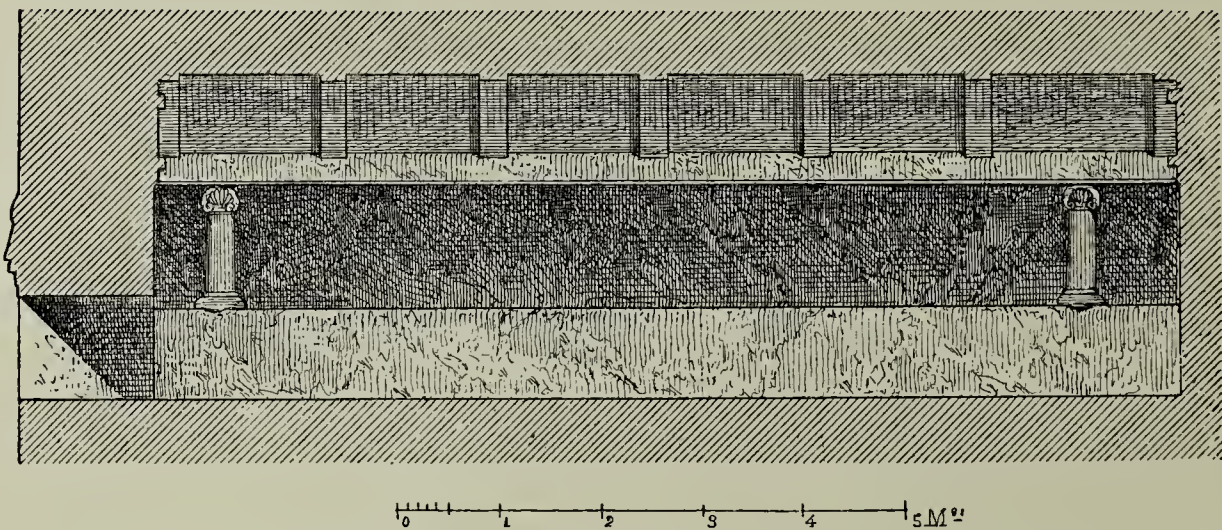

FIG. 70.—The Broken Tomb. Restored longitudinal section through east face.

¹ We are happy to say that our restoration of the broken tomb is in perfect agreement with Professor Ramsay's (*Journal*, ix. pp. 354-364, Figs. 1-9). His "inner restoration" corresponds in every respect with the perspective view offered by M. Chipiez (Fig. 71), and reference to his inner sections (Figs. 4 and 7) will tell the reader the position occupied by the pictures in the building. This is carefully indicated by dotted lines.

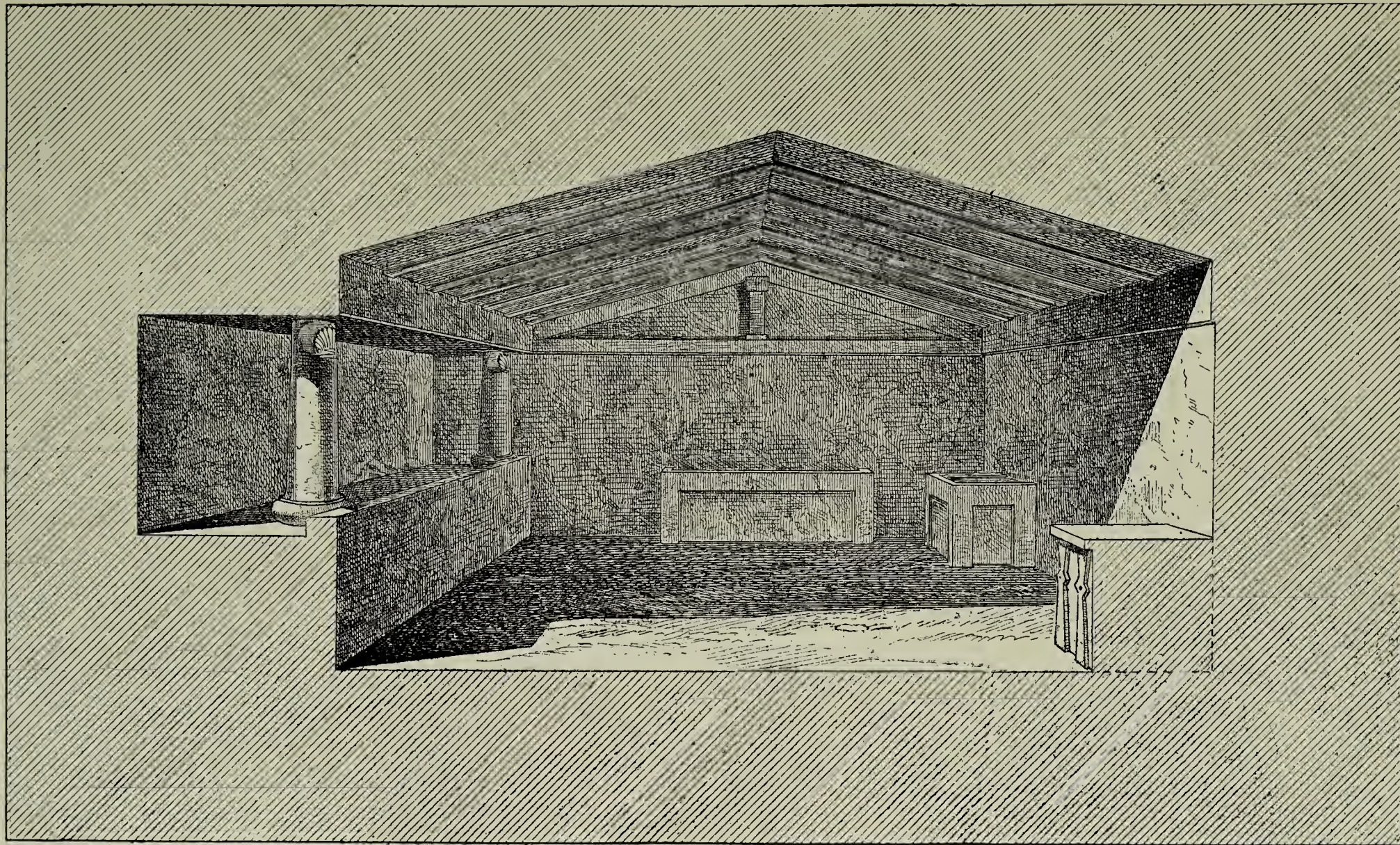

FIG. 71.—The Broken Tomb. Restored perspective view of interior of vault. Drawn by Ch. Chipiez.

adhering to the external portion of the fragment; ¹ the other, or inner side, had a mortuary bed (Fig. 65, right-hand block). Of the third lion on this side, the head and shoulder are extant (Fig. 65, on the left). It was near the north-west corner (Fig. 66, F), and faced north (Fig. 121), his back turned against the pair. Taken from the tip of the nose to the back of the neck, it measures 1 m. 28 c. The pose of the animal must have been very similar to that of the two lions seen at the entrance of tomb (Fig. 64).²

Finally a bas-relief, composed of three figures, took up the whole of the northern side (Figs. 117, 118). It represented two warriors (Fig. 66, G G) in the act of spearing a Gorgon-like monster, whose head appears over the door (Fig. 66, H). This side is now broken into two huge blocks. The larger fragment answers to the north-west angle of the tomb; it still preserves the settee (Fig. 66, c), the head and shoulder of the lion (Fig. 65), and the best half of the northern façade. Our woodcut shows its present situation. The block bearing the right-hand warrior, the door, and the Gorgon has its external side turned against the ground; as also the second fragment with the left-hand warrior, but this has suffered far more from the fall and the weather, and looks as if excoriated, the helmeted head of the hero being the only part visible. Nor are these the only lacunes; the block to the dexter hand betrays no trace of the lower part of the figures. Did the artist content himself with busts, or did he sculpture full-length figures? The latter hypothesis is the more likely. The chances are against the door having been on the level, but they are many for its having been high up in the façade, so as to afford ample space below it for figures of normal size. It is to be deplored that the tomb we are considering should have met with so untoward a disaster.

¹ This is the fragment very imperfectly figured in the first instance in *Hellenic Studies*, 1882, p. 222, Fig. 6, and of which a better drawing was published in the same *Journal*, vol. ix.

² It is a matter for surprise that M. Ramsay's labours with regard to this tomb should have resulted in the discovery of but the two fore-paws of the lions facing each other. Hence he raises the question, which he answers in the negative, as to whether the body of the animals ever existed. Two single isolated paws standing out from the wall without rhyme or reason would, in truth, have been an odd device. He thinks it not improbable that the bodies of the animals may have been utterly destroyed when the chamber fell in, part of whose walls was crumbled to dust. Whilst having our doubts on the subject, and not having seen the tomb, we cannot but accept (though under reserve) the restitution offered by one who has explored the site with untiring perseverance and curiosity.

Had it been preserved, no finer or more important specimen of Phrygian art could have been held up for our admiration; inner arrangement and monumental sculptures, all combine to render it a fit companion to the Midas façade.

In the pillar supporting the sloping roof, we recognized a wooden post imitated in stone; but we are unable to pronounce in regard to the obelisk-like shape seen over the doorway (Fig. 64). It has suffered too much from the weather, its contours are too indistinct to permit of a conjecture one way or another. On the other hand, it is pretty certain that the object which appears in the same position in one tomb of this necropolis is a phallus.¹ Of the idea and feelings which led to this symbol being set up on the top of a funereal mound, above the entrance to a grave-chamber,

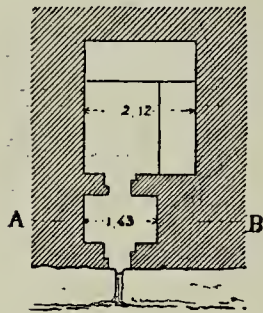

FIG. 72.—Plan.

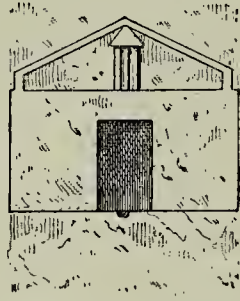

FIG. 73.—Façade.

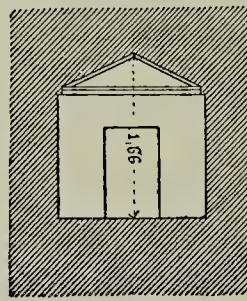

FIG. 74.—Section through A, B.

Figs. 72-74.—Tomb near Pishmish Kalessi. PERROT and GUILLAUME, *Explor. Arché.*, tom. i. p. 146.

where it sometimes forms the sole decoration, we have spoken in another place. This is well exemplified in the tomb called Pishmish Kalessi (Fig. 100, D), from the fortress which rises on the summit of the crag in whose flank the grave-chamber was hollowed. Its arrangement will be easily grasped by reference to plan (Fig. 72), elevation (Fig. 73), and transverse section through the vestibule (Fig. 74) made by M. Guillaume in 1861, the date of our visit when we brought this interesting specimen to the knowledge of the world.

The tomb consists of a vestibule and a chamber, the latter having two funereal beds. The entrance of each apartment bears traces of pivot-holes for the door or covering slabs. A runlet was cut in the exterior grave so as to drain percolating water. In the centre of the pediment was a stave or pole, with a triangular cap, and streaked by three vertical striæ. The notion that this sturdy upright was copied from a piece of carpentry need not be entertained, for a wooden post would have been inadequate to uphold

¹ The explorers familiar with the tombs of Phrygia are almost unanimous in viewing the object in question as a *linga* (BARTH, *Reise von Trapezunt*, p. 94; PERROT and GUILLAUME, *Explor. Arché.*, p. 146).

the heavy frame of the roof. Some have thought that this was a stick with a Phrygian cap;¹ but nothing proves that the cap in question, which only crops up on very late monuments, was at that time the national head-dress of this district of Asia Minor; and, what is more, will any one explain its meaning on the top of a pole, and its business about a tomb? On the other hand, we can easily account for the part played here by the phallus, as well as the significance that may have been attached thereto. Did we not observe it in Cappadocia, as centre-piece of an *ædiculum*, a place usually reserved to the deity?² Was it not put on the summit of tumuli in the neighbouring necropolis of Smyrna?³

As to the conventional form it has assumed here, it may be explained on utilitarian principles, in that the artisan could fashion in no time, and at small expenditure of labour, those cippi in stone or wood that were so important a feature of the naturalistic religion of Syria. The frequent parallelism Hebrew writers establish between Asherahs, sacred poles, and Ashtoreths or Astartes, goddesses of love and life-giving, led us to suspect that cippi—found in such abundance in Phœnicia and in her dependencies—had a phallic meaning.⁴ The sample we reproduced from Kition⁵ is precisely similar to that which served as model to the Phrygian sculptor; a symbol he again figured in the Yapuldak tomb, which likewise belongs to this necropolis, and which, from an artistic standpoint, is in advance of the Pishmish Kalessi example (Fig. 75).⁶ In each case plinth, quadrangular cube, and pyramidion are identical; making up a type which from Southern Syria must have passed to the Hittites—worshippers of Ashtoreth, and spread from the valley of the Orontes and Cilicia to Cappadocia and throughout Asia Minor. Hence it came to be regarded as an indispensable adjunct in the public worship of the various nations, whose religion was based on the great concept of an eternal and never-ceasing creative force, and a deep sense of the homage it should receive. This is the type we are inclined to recognize

¹ This was the opinion of the late Mordtmann, the companion of Barth (*Reise von Trapezunt nach Scutari*, p. 93).

² *Hist. of Art*, tom. iv., pp. 646, 653, Fig. 321.

³ *Ibid.*, tom. v. p. 51, Figs. 18, 19.

⁴ *Ibid.*, tom. iii. p. 385.

⁵ *Ibid.*, tom. iv. Fig. 203.

⁶ Stewart, Plate XV.; BARTH, *Reise*, p. 93; RAMSAY, *Journal of Hellenic Studies*, tom. iii. pp. 256, 257, Plate XXVIII. n. 4.

in the Hittite character (Fig. 76), which in Cypriote writing appears in a more cursive form.

The tomb whose façade we reproduce (Fig. 75, 2 in map) is

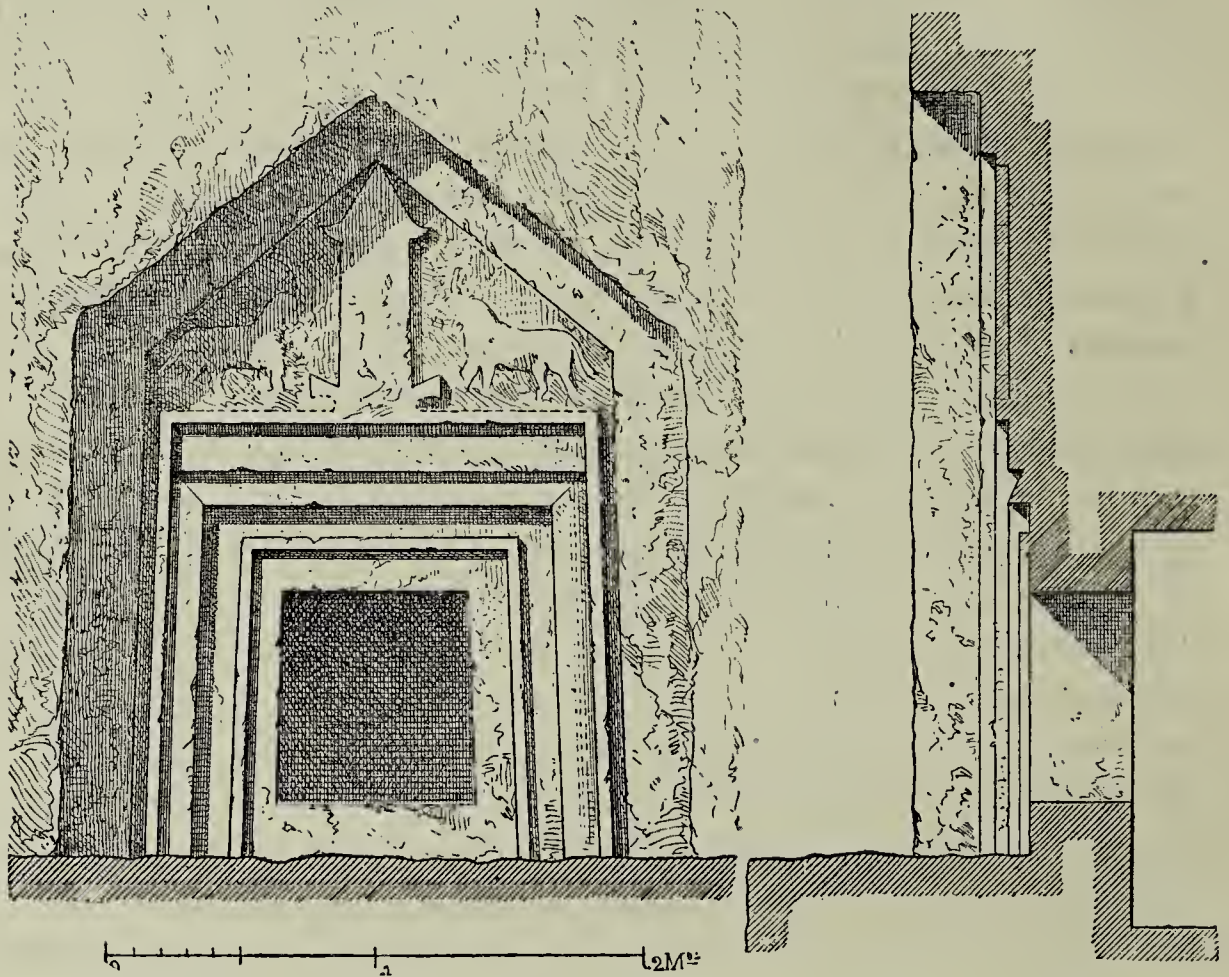

FIG. 75.—Tomb at Yapuldak. Elevation of façade and section through axis of the same. *Journal*, Plate XXVIII.

found at Yapuldak. It consists of three chambers in a row extending right through the hill, and may be likened unto a tunnel with opening at either end, or east and west. The hypogee opens on to a spacious platform facing eastward, with parapet cut in the stony mass; down it the rock has not been touched, and has been left in its native state. On this side, too, was certainly the path taken by the funereal procession and the friends of the deceased, as they wound up the gentle acclivity of the hill, conveying the dead to these artificial grottoes. The efforts of the decorator were concentrated on the posterior façade, which faces northward and dominates the valley; whence, about half-way up, the wrought front may be



FIG. 76.—Hittite character. WRIGHT, *The Empire of the Hittites*, 2nd ed., Plate X., 1, 4.¹

¹ The sign is likewise figured by PROF. SAYCE, *Monuments of the Hittites*, p. 28, n. 3.—TRS.

descried standing out from the almost perpendicular ledge of rocks. A man must needs have sureness of foot and a head not given to dizziness to scramble up these, catching at every projecting stone until the base of the monument is reached. Here he may sit down on the cornice, about 50 c. broad, which forms a kind of parapet along the front, and examine it at his leisure; conscious, however, that the slightest movement backwards will send him spinning some 40 m. below.

The bay is 25 c. above the soil and cir. 50 c. above the floor of the first chamber; so that it looks like a rent in the rock rather than a door properly so called. Its width is somewhat less towards the top than the bottom. This gentle, almost imperceptible salience of the lines one upon another, extends to the fascias surrounding the door, which form as so many frames around it. In the tympan, right and left of the rude obelisk just described, are two walking animals face to face. Stewart saw in them two horses; Barth and Ramsay are both of opinion that the one on the right, which still preserves some sort of outline, has a faint resemblance to an ox, and is as far removed from a horse as can well be. The worn state of the other does not permit to give formal expression as to the species to which it belongs.¹

The three chambers are small, and the roof-shaped ceiling has a double slope. Over the inner door, which communicates with the second chamber (assuming the main entrance to have been on the west side), is carved a pillar with volute capital. It is the sole ornament of the interior; no couches, no troughs for receiving the bodies. In face of the bare aspect and exiguous dimensions of the chambers, it is not easy to conceive how they could have been subterraneous dependencies of a domestic dwelling, which formerly stood on the platform, the inner side of which leans against the cliff.

But what even more tells in favour of its being a tomb is the characteristic symbol carved on the posterior façade, a symbol we have observed about the doorway of an hypogee whose funereal purpose cannot be questioned.

As far as we have gone, the monuments we have described betray no arrangement, no element which may be taken to denote acquaintance with and imitation of alien models. This does not apply to a large number of tombs in this very district, and more

¹ M. Ramsay is rather inclined to think that it is a horse.

particularly those of the Ayazeen necropolis. Here multitudinous indications enable us to grasp that the artisans were beginning to feel the influence of Grecian art, albeit in the main they still adhered to the traditional processes of a former age. A certain class of subjects—animals in pairs, for example, whether passant or rampant—had taken too firm a foothold on Phrygian soil not to have

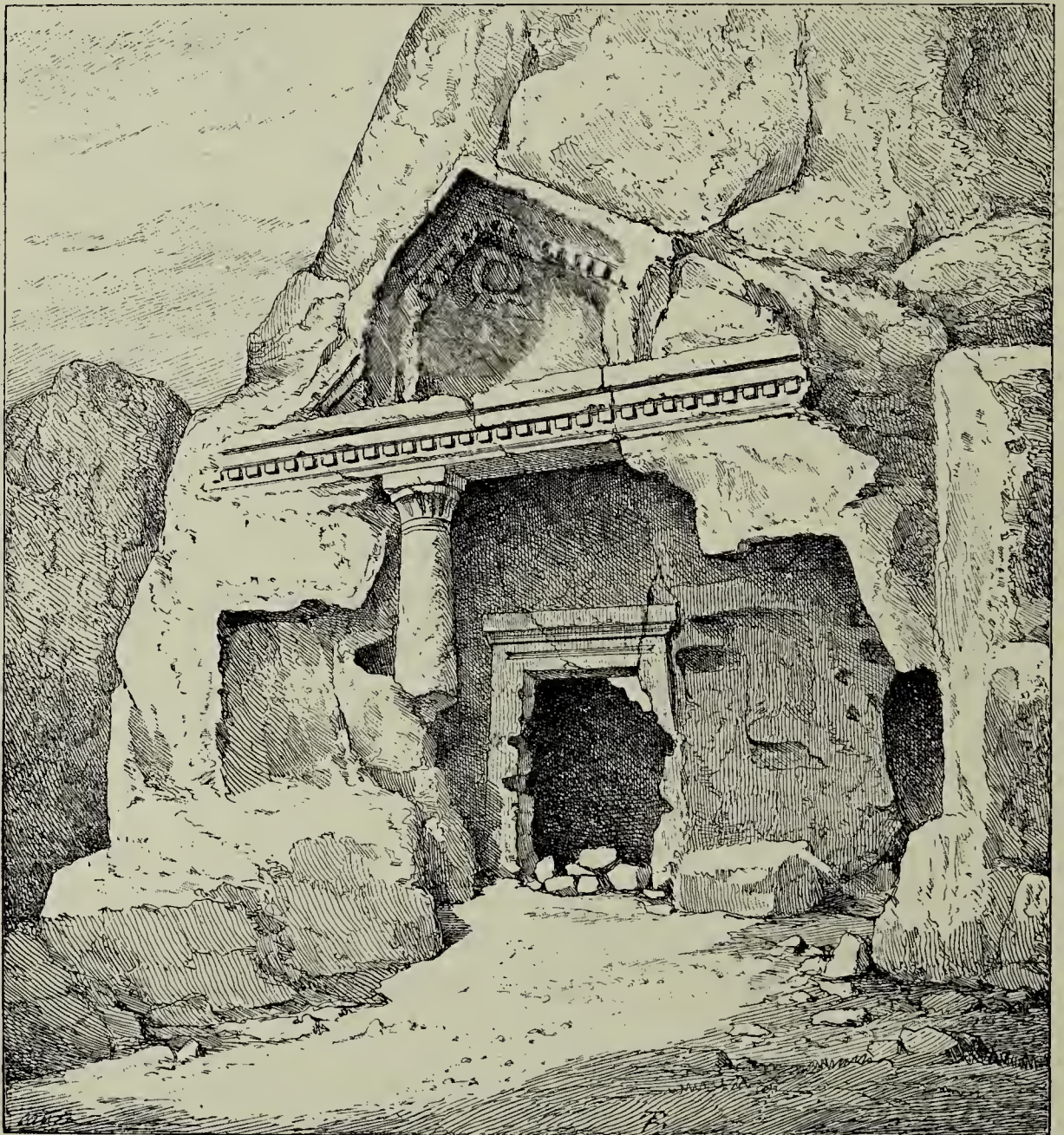

FIG. 77.—Tomb near Ayazeen. Façade. *Journal*, 1882, Plate XXVI.

been maintained for many centuries. Two or three specimens will suffice to give the reader some notion of this intermediary and composite style.

MM. Ramsay and Blunt were the first to make known an hypogee which, to judge from the number of its troughs, must

have been an important family vault. It was decorated by a porch, but the whole of the richly ornamented façade is much defaced (Fig. 77, 32 in map). It is entirely rock-cut; of the two columns which upheld the entablature, one has disappeared without leaving a trace, and of the other the upper part alone remains in position, hanging from the architrave. Right and left of the twin pillars appear two salient members which terminated in small frontals. Were they supported by colonnettes, so as to render them proportional to their surroundings? Had the chisel carved an ornamental device or inscription upon it? In the worn state of the stone surface, nothing can be affirmed either way. The entablature is formed by an architraved cornice, the profiles of

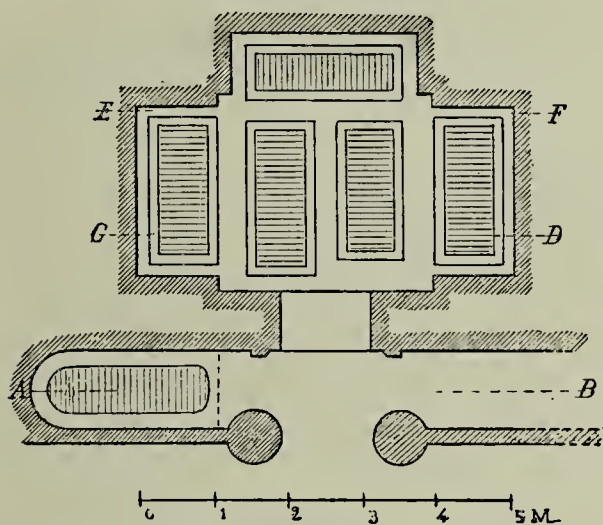

FIG. 78.—Plan. *Journal*, 1882, Plate IXXVI. A.

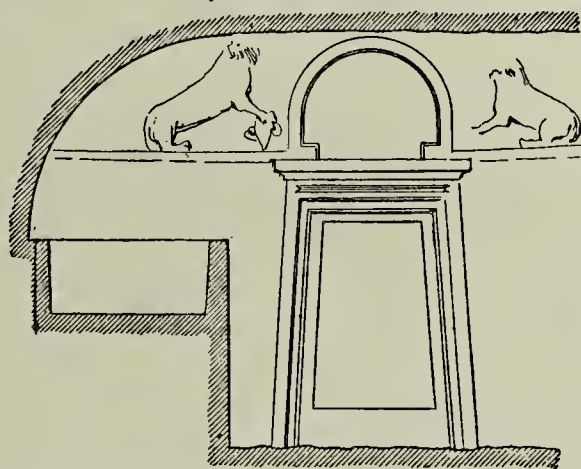

FIG. 79.—Transverse section under porch, through line A, B. *Journal*, 1882, Plate XXVII. B.

which are repeated on the sloping sides of the very pointed pediment crowning the whole. The details about frontal and entablature should be noticed. In the middle of the tympan appears an indistinct object.¹ Was it a Gorgon's head, or rather a simple wreath? It is difficult to say. Behind the porch is the entrance to the tomb, a bay with sloping jambs (Fig. 78). Within the porch, flanking the arch which appears over the lintel, are two semi-rampant lions face to face (Fig. 79); a device repeated on the end wall of the chamber opposite the entrance (Fig. 80). The decorative scheme had variety. Thus, on the inner side of the wall in which the door is pierced, were two oblong panels which, to judge from their shape, contained human forms, but so hopelessly obliterated that no explorer has cared to

¹ *Some Phrygian Monuments*, p. 262, Plates XXVI., XXVII.

commit himself as to their sex (Fig. 81). Over the door, equally ill-determined and obscure, is repeated the subject, which externally occupies the centre of the frontal. The whole apartment was set out for the accommodation of the dead; the end and side walls had each a niche, arched at the top, and troughs were hollowed in the floor of the chamber. No room was found for a late arrival, so that a couch had to be cut within the porch on the left-hand side.

A similar mingling of architectural and ornamental forms may be observed in other hypogea around this tomb and the flank of the hill, in which the lions reappear.¹ Of the many tombs Professor Ramsay has published, we will content ourselves with

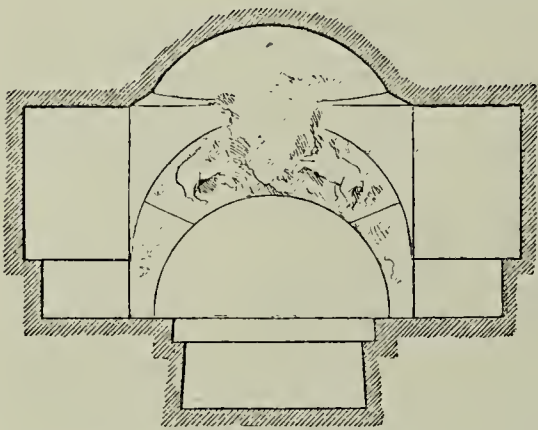

FIG. 80.—Transverse section through line E F.
Journal, Plate XXVII.

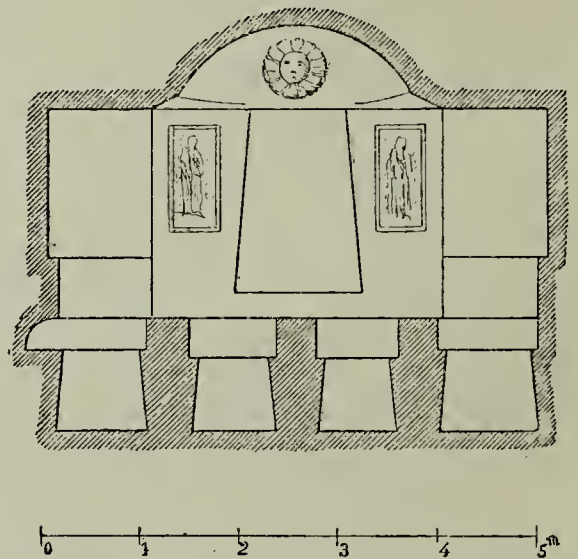

FIG. 81.—Transverse section through line G D.
Journal, Plate XXVII. C.

singling out the example whose façade is adorned by two Ionic columns (Fig. 82, 31 in map).

Nor is this the only necropolis wherein works of an art slowly undergoing transformation are met with; instances likewise occur in the northern district, in the neighbourhood of Nacoleia. The most curious specimen of this class is the fine tomb, still in very good preservation, cut at the base of the rocky ridge upon which the village of Kumbet is planted (Fig. 83). It has a great advantage over the tombs of this canton in that it has been studied by an architect,² whilst the good condition in which it is found

¹ *Hell. Studies*, Plates XXVII.—XXIX.

² G. PERROT and GUILLAUME, *Explor. Arché.*, pp. 138, 342, 368. The following figures (Figs. 84–88) are reproduced from drawings made by Guillaume. Sketches of this tomb had been previously published by Stewart, pp. 6, 16; by LABORDE,

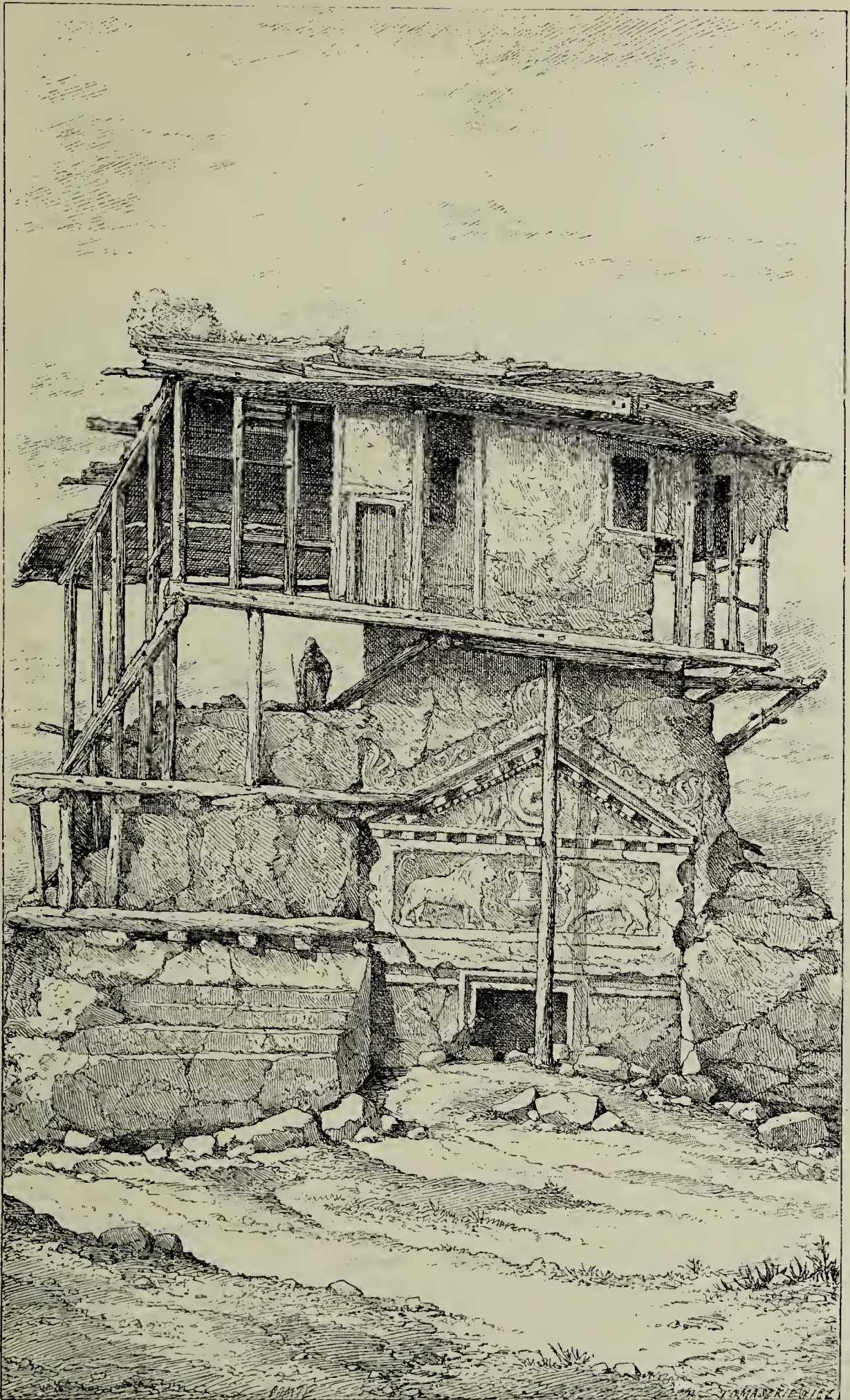

FIG. 83.—The Kumbet Tomb. General view. From a photograph of J. Delbet.

renders it an admirable subject for comparison. Then, too, we enjoyed a liberty of action unknown to our predecessors, whose operations had been impeded by the situation of the Agha's kiosk, built right over the monument. His public room stood over the tomb proper, whilst the grave-chamber was turned into a store-room. This particular Agha, said the old men of the place, was

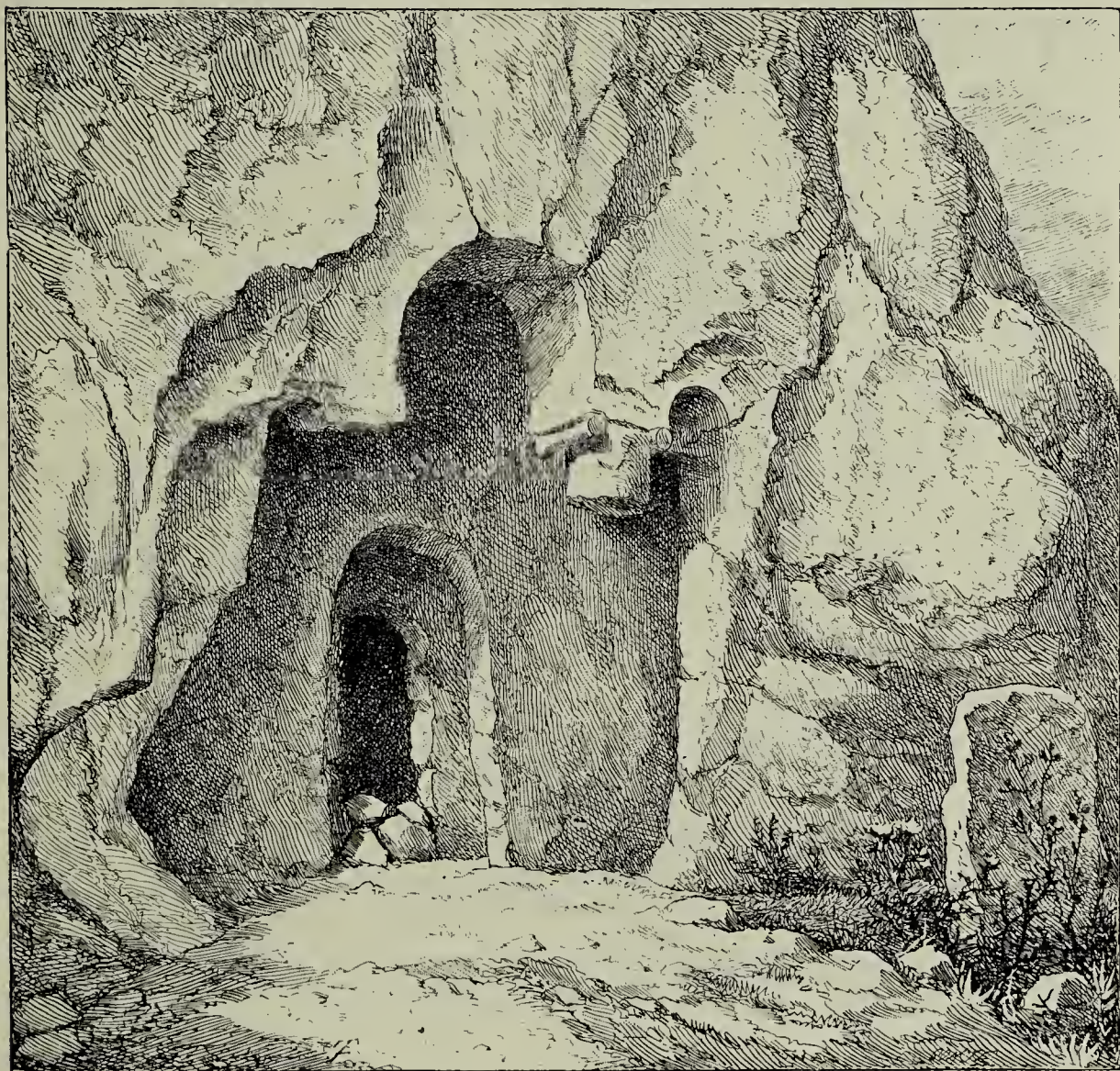

FIG. 82.—Tomb at Ayazeen. *Journal*, Plate XXIX.

one of the last representatives of old-fashioned Derey-Beys, or independent native princes, and noted for his atrocities; suspicious, too, of any European lurking about, pencil in hand, as boding no good to the konak. By stealth only, and whilst this terrible ogre was enjoying his siesta, did De Laborde at last succeed in

Voyage d'Asie Mineure, pp. 78, 79, Plates XXIX., LXIV., LXV.; *Barth, Reise*, p. 90. But as these travellers gave no plan or measurement of the memorial, no good or exact idea could be formed of its style.

making a drawing of the tomb. As for its occupant, he was put to death by order of Sultan Mahmoud; and the upper story he had added to it has been empty ever since, and is rapidly falling into decay. Our illustration of this picturesque konak is from a photograph taken at the time of our visit (Fig. 83). Nothing would have been easier than to clear its base of the silt that has gathered around it, but for the fact that we found the village

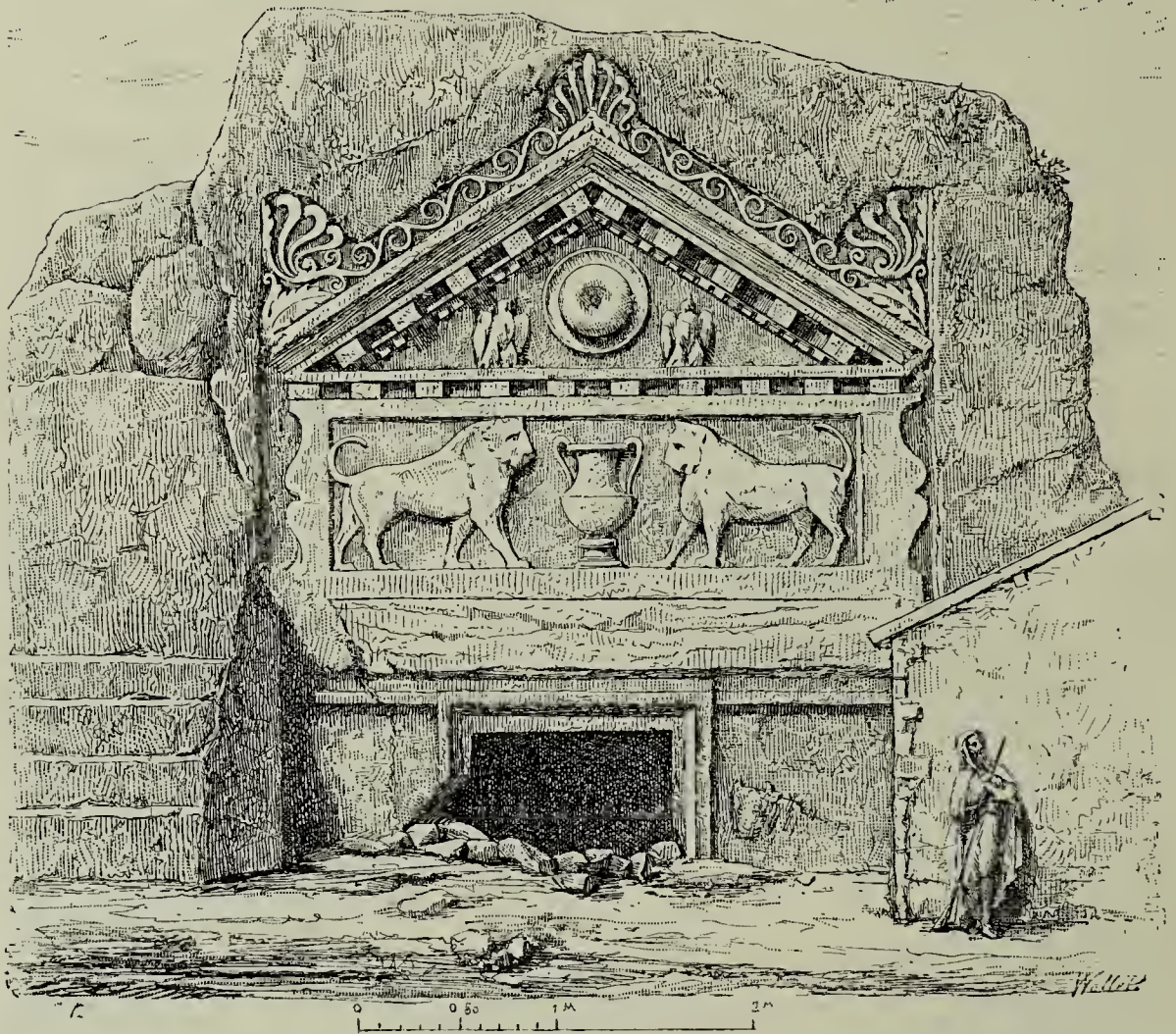

FIG. 84.—Façade of the Kumbet tomb. Drawn by E. Guillaume. *Explor. Arché.*, Plate VII.

deserted of its inhabitants, who had betaken themselves to their tents during the summer heat, and were camping in the woodlands some two or three leagues away.

Like the Midas rock and the Delikli Tach, the Kumbet tomb is no more than a sepulchral front cut in a rocky mass, the stone surrounding it being left in the rough (Fig. 84). Steps appear on the left side, but whether coeval with the tomb or comparatively recent, it would be difficult to say. Their purpose,

whatever it was, could certainly not be to reach the chimney, obtained, as at Delikli Tach, in the vertical plan of the tomb above the grave-chamber. There never existed here an opening of this kind, as everybody may see for himself if he will take the trouble of entering the double grave, pierced right through the rocky mass in which the tomb occurs (Fig. 85). The false bay of the older rock-cut façades has been replaced by a real door, surrounded by double mouldings, which opens in the centre of the frontispiece. Curious discoveries might be ours, had attempts been made to ascertain the possible existence of a substructure, and study the old soil hidden under accumulated earth, which can scarcely be more than fifty centimetres below the present level, proved by longitudinal section (Fig. 86). Right and left of the door, between the jambs and the outer edge of the façade, appears a sculptured figure. On the dexter hand it is the front part of a bull, with a hump on his back, like the bison of America and the Indian zebu; the variety no longer exists in Anterior Asia, but we find it figured on the autonomous coins of this province, on those of Ancyra,¹ Eumenia,² Kibyra,³ as well as in the bas-

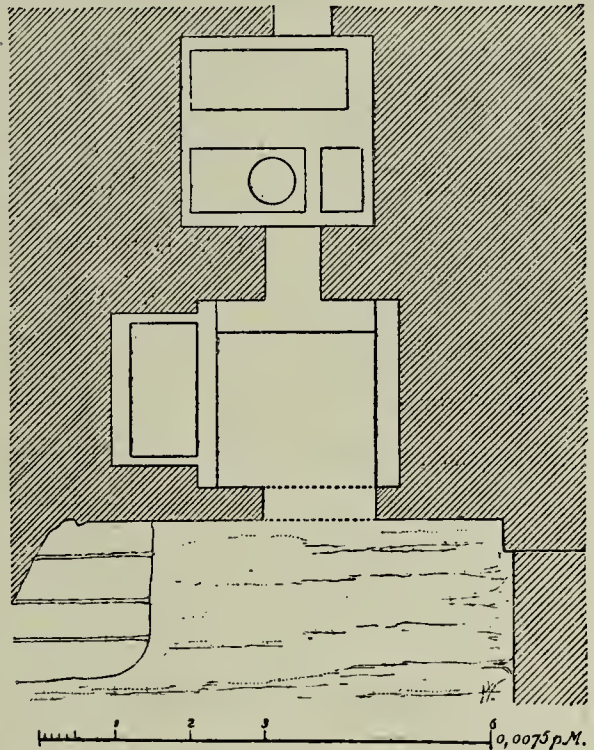

FIG. 85.—Kumbet tomb. Plan. *Explor.*, Plate VII.

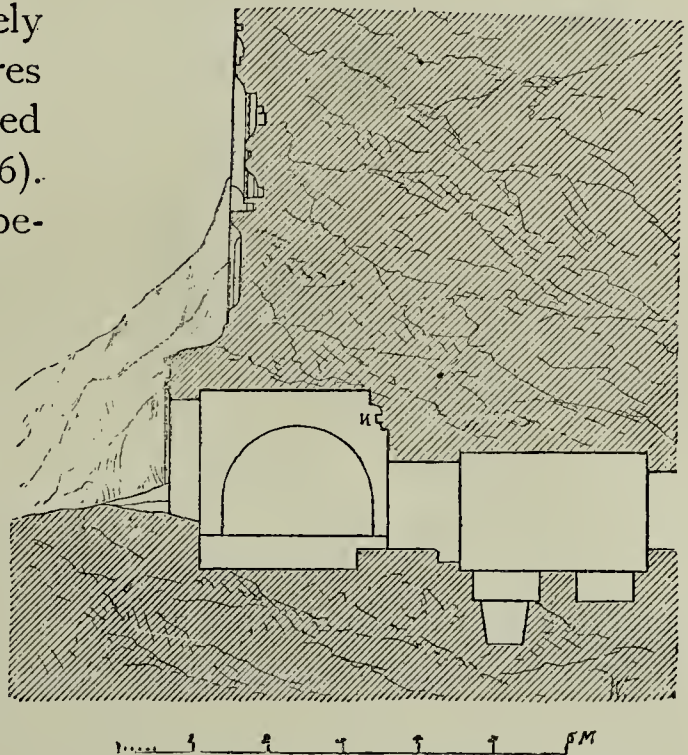

FIG. 86.—Kumbet tomb. Longitudinal section. *Explor.*, Plate VII.

¹ MIONET, *Médailles grecques et romaines*, tom. iv. p. 219.

² *Ibid.*, p. 293.

³ *Ibid.*, p. 28; *Supplément*, tom. viii. p. 533.

reliefs of the theatre of Aizani.¹ On the other side, owing to the depth of the silt, we could descry nothing. The drawings of our predecessors, however, show a Gorgon's head.² Over the doorway ran a cornice, now almost obliterated, and over it again was

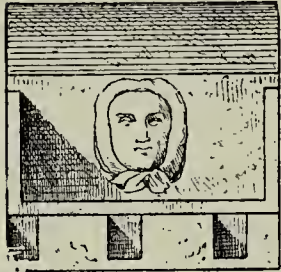

FIG. 87.—Kumbet tomb. Sculptured head in cornice. *Explor.*, Plate VII.

a bas-relief flanked by semi-balusters. The middle of the field is occupied by a double-handled vase of simple, elegant design. Numbers may be seen in our museums, labelled "Italo-Græco," whose contour is precisely similar. A lion and a lioness are seen on either side of the vase; they look at each other, and advance as if to drink out of it. The bas-relief is separated from the frontal by a narrow cornice, upheld

by large modules or modillions which reappear under the side beams of the roof; but between each module come out small heads finely carved (Fig. 87). Below them are dentals. The corona of this pediment is allied to the native rock by an elegant foliate scroll, terminating at the angles



FIG. 88.—Kumbet tomb. Palmette at angle of cornice. *Explor.*, Plate VII.

and at the top in graceful rich palmettes and acanthus-shaped leaves (Fig. 88). Such is the external aspect of the monument. If we pass the rectangular door and enter the chamber, we shall find a single vaulted grave scooped in the left wall. A passage narrower than the entrance gives access to the second chamber, which is somewhat lower than the first, with semi-circular arch. Its arrangement is different: three sarcophagi of unequal size are

pierced in the floor, and at the bottom of one opens a circular hole which sinks into the rock. It was filled with earth. To our thinking the work about the walls and troughs is less good than that of the first chamber, and betrays hurry and a modern hand, as if this had been a later addition pieced on to the original

¹ PHILIPPE LE BAS, *Voyage Arché.*, fol., Plate XIV.

² In Stewart's Plate the head is shown with luxuriant hair; two concentric circles are all Bartle has given.

plan. What tends to confirm our hypothesis is the inscription, in large letters, engraved over the doorway by which the second chamber is entered (Fig. 89). It reads as follows :—

ΕΟΛΩΝ ΚΕ ΕΝΘΑ

Σόλων κε[ῖ](ται) ἔνθα.¹

The shape of the characters, as well as the contractions, prove their late origin, and may be dated from the Roman dominion, in the third or second century of our era. Its interest resides in the fact that it testifies to a habit with which numerous instances have made us familiar.

In the last centuries of antiquity, it often happened that, to save themselves the trouble of hollowing a fresh tomb in the depth of the rock, they took possession of those the men of old had prepared for themselves, when, no doubt, the first to be usurped were the most ancient. The more recent were guarded either by the surviving members of the families who had consecrated them, or, at least, by the stringency of the laws which the Treasury, interested in the matter, had enacted for the purpose. No such obstacles were to be apprehended in the earlier monuments, in which were buried the nameless sons of a forgotten race, whose pinch of ashes had been scattered to the four winds of heaven, and which, moreover, had long since been desecrated and rifled. Thus, under the golden rule of the Antonines, one Solon, a native magnate, found it convenient to appropriate to himself a tomb of a certain repute. Then it was that the second chamber was added, with the inscription giving the name of the owner. As to the opening in the farthest wall of this chamber, we found it choked up by potsherds and stones; so that we failed to make out whether it was coeval with the monument, or whether it had been pierced through the thin rocky wall by the Agha, to enable his servants to enter the vault, used as lumber-room, through the courtyard.

Externally we found no trace of stucco; but in the hollows, notably about the palmettes at the sides, are still patches of vivid red. Internally, a rude gorge, ornamented by vertical stripes of

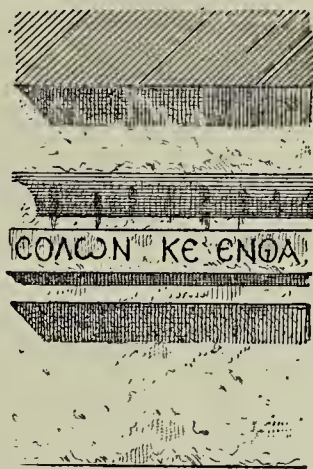

FIG. 89.—Kumbet tomb.
Inscription. *Explor.*,
Plate VII.

¹ With regard to the restitution of the above text, see PERROT, *Explor. Arché.*, p. 140.

the same colour (Fig. 89), appears as part of the cornice above the second doorway (Fig. 86, N); a mode of enrichment likewise found in cavettos of similar aspect, both on the monuments of Egypt and the capitals of antæ in the Propylæa at Athens.

As last example of the transition period we will cite another

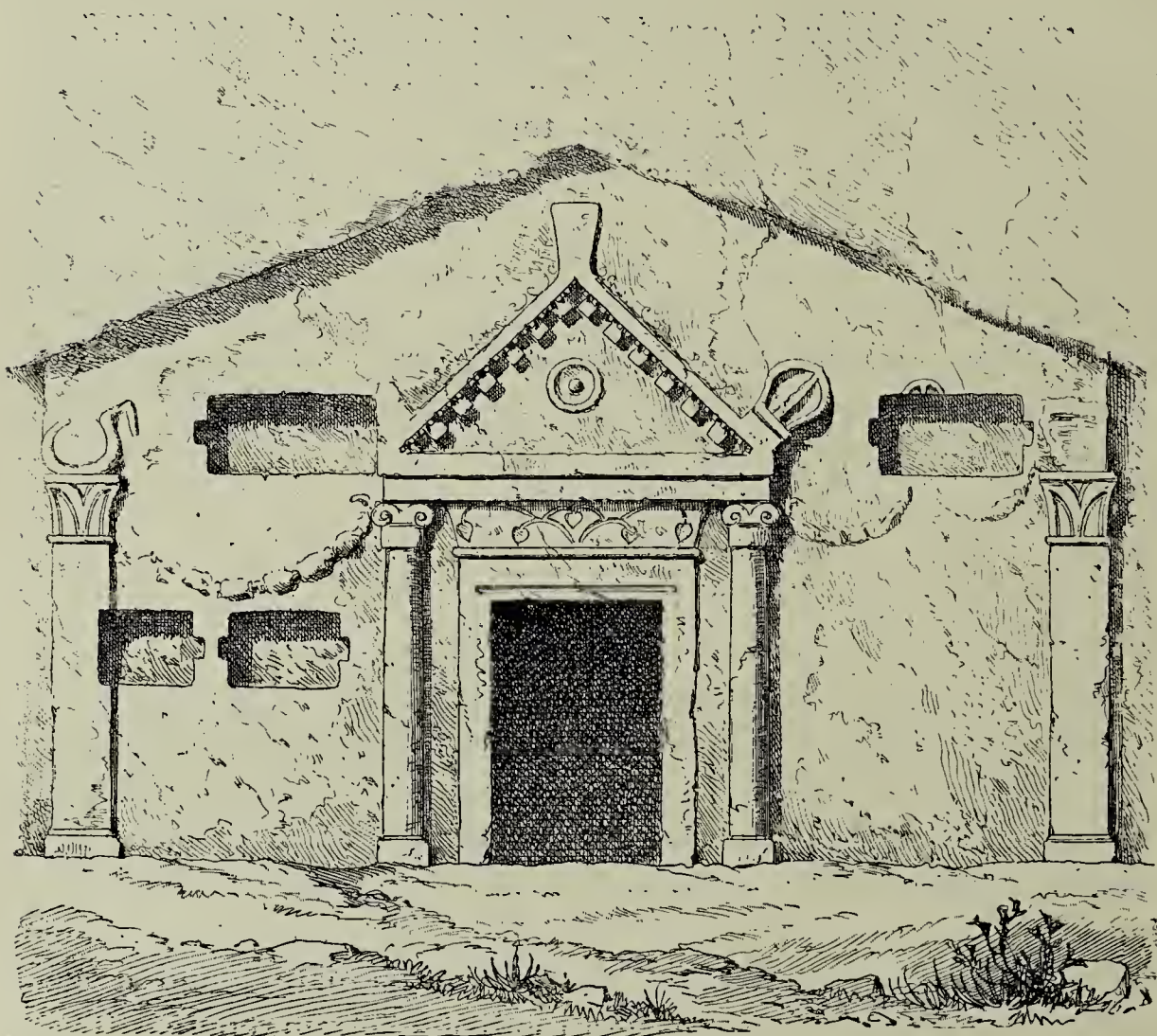

FIG. 90.—Tomb at Yapuldak. Drawn by Blunt.

tomb at Yapuldak (Fig. 90, 2 in map¹), the complex decoration of which attracted the attention of MM. Barth and Ramsay. Although ruder in manipulation, this façade resembles the Kumbet example in too many points not to come very near it in date.

¹ Ramsay, whilst sending us his sketch of the Yapuldak tomb (Fig. 90), which we reproduce, warns us against that made by Barth, as quite incorrect. The reader will find a plan, elevation, and sections of this same tomb in *Journal*, x. Figs. 28-33, pp. 182-184. Internally, the head of the Gorgon is repeated in fantastic varieties over the doorway and the three graves or arcosolia. The monument seems to be one of the youngest in the necropolis.

Thus rectangular door, shape and size of pediment, modillions, and dentels in the cornice which form the coping, proneness to adorn the top and angles of the frontal by means of devices which, if less elegant, have none the less the same value, are identical in both, even to the shield in the middle of the tympan. Differences are shown in the two columns, in touch with the wall, on either side of the doorway which uphold the entablature; the pilasters at the outer edge of the façade, and the rudimentary capitals upon which are put dissimilar objects. Of these, that to the right seems to be a vase, or funereal urn, instances of which are plentiful in these hypogea. Bandelets and necklaces intervene between column and pilaster, whilst a foliate scroll above the lintel graces the doorway. The ornament throughout is very much injured, and the general aspect is further marred by rectangular niches pierced in the façade, but for what purpose it would be hard to guess. With the advent of Christianity the tomb must have served as chapel or domestic dwelling.

As years rolled by, Hellenic art crept in and became dominant in Phrygia and the peninsula generally, and replaced all that had gone before. About the centre of the northern necropolis which surrounds the Midas monument, a tomb is described, which, like one of the exemplars in Pteria, goes by the name of Gherdek Kaiasi (the Rock of Marriage) (Fig. 91, 3 in map).¹ The architecture of the façade is clearly Hellenic Doric, with all the elements characteristic of the order. If the columns are smooth, it is because the fluting, which is easily obtained when the shaft is made up of several pieces, cut and prepared in the stone-yard, would have offered real difficulties, and required a whole system of scaffolding, with a support of great size taken from the actual mass of the rock. Hence, reverse curves, or

¹ *Hist. of Art*, tom. iv. Fig. 345. The monument is a double chamber, which the peasantry imagine contains husband and wife, whence its name "Gherdek Kaiasi" (the Rock of Marriage). It has been published by Stewart, Plate XII., and by TÉXIER, *Description*, Plates LX., LXI. But the elevation of the latter, he informs us in the text, is a restoration (tom. i. pp. 158-162). Part of one column alone remains in position hanging from the architrave. M. Ramsay writes that the Doric façade, our Fig. 91, after Téxier, is inexact. I suspected as much. On the other hand, it is to be regretted that he has not thought fit to supply a better one himself. As far as he can recollect, he says, the monument has a more massive character, the pillars are stouter than Téxier represents them. I must demur against the words put in my mouth, that "in style it was Roman Doric;" what I did say was that "it recalled the attenuated proportions of Roman Doric."

flutings, are, as a rule, non-existent in the rock-cut façades.¹ With this exception, the frontispiece of this tomb is that of a Greek temple; but it is neither the temples of Pæstum, the

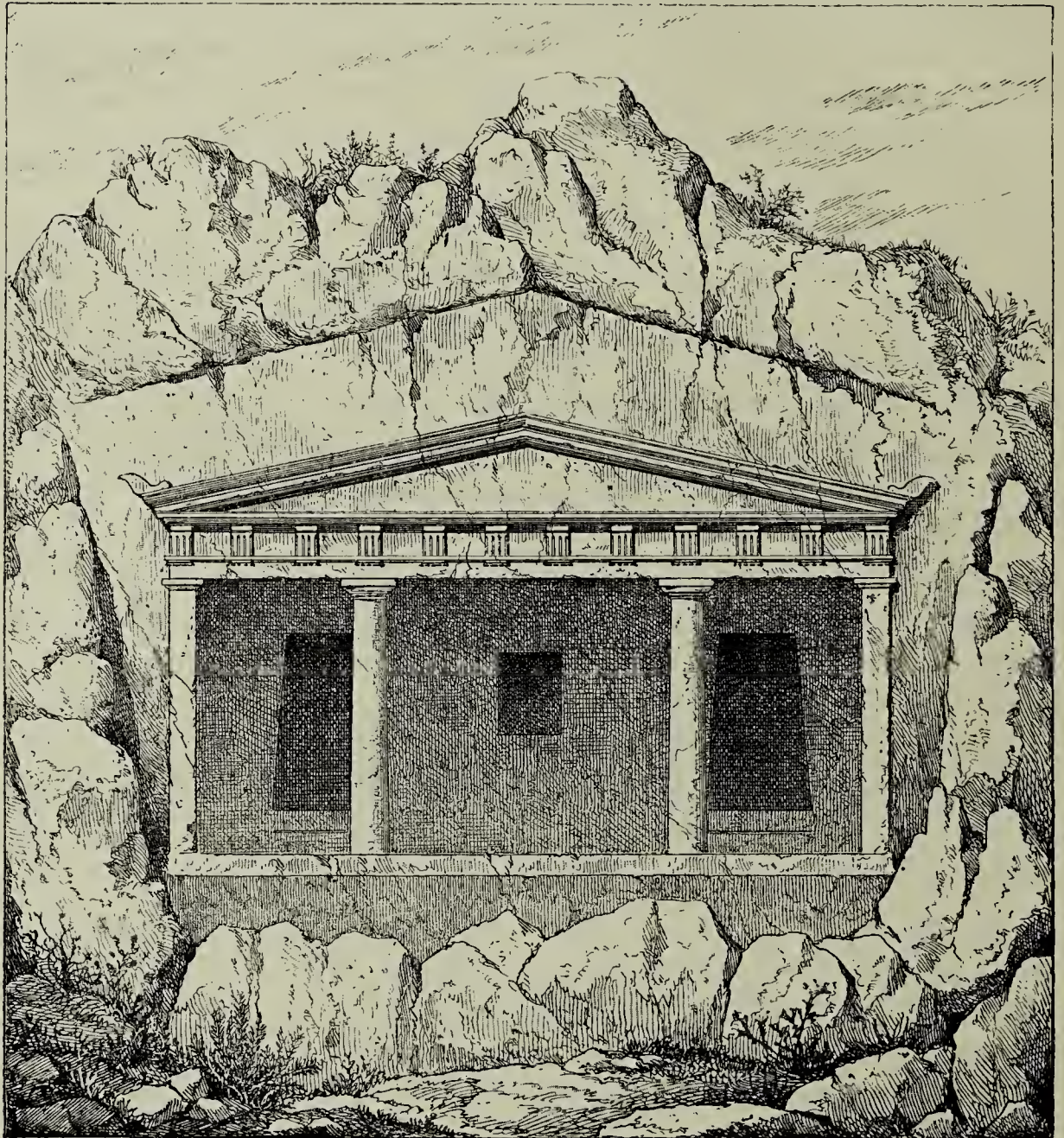

FIG. 91.—Gherdak Kaiasi. Restored façade. TÉXIER, *Description*, Plate LX.

Parthenon, nor the Propylæa of the Athenian acropolis, which are thus recalled, but rather the slender proportions, the wide

¹ For the Doric order, this is exemplified in the tombs at Paphos (*Hist. of Art*, tom. iii. Fig. 161), and in the Jewish tomb which goes by the name of St. James, at Jerusalem (*Ibid.*, tom. iv. Figs. 143, 144); for the Ionic order, in the so-called tomb of Absalom (*Ibid.*, Figs. 141, 142). We can do no more in this place beyond referring the reader to the monuments, illustrative of the two orders, which have been published in our former volumes.

intercolumnation of Roman Doric, well exemplified in the temple of Heracles at Cori. The monument cannot be carried back beyond the Seleucidæ; it may even date from the days when Phrygia formed part of the kingdom of Pergamos, or of the Roman empire.

We find greater difficulty in fixing the dates of those monuments in which the true arch is seen side by side with the triangular pediment; inasmuch as there are elements about them which persisted down to the opening years of our era in well-known tombs of Caria and Syria. Nevertheless, sundry indications lead to the inference that our Phrygian tombs belong to an older epoch, and are the outcome of a local art, which, though in a certain degree open to Greek influence, was by no means slavish, and still clung to the methods of former ages. Of these signs we will single out the most noteworthy.

In many of these monuments, chevrons form the ornament of the archivault which appears over the doorway, a device never used by the Greeks in that situation. Such would be a tomb in the Ayazeen necropolis (30 in map), whose façade displays, moreover, a pair of lions carved over the entrance, and a shield in the tympan (Fig. 92).¹ This chevron device brings to mind, though in an abridged form, the crenellations the Assyrian artist distributed about his fortresses.² It likewise occurs in Cappadocia, as robe-ornament of the deity who occupies the centre of an *ædiculum* carved in the Pterian sanctuary.³ Then, too, as a rule in our monuments, frontals are taller and more pointed than in Greek buildings. Their mode of attachment is clumsy; for they are not the prolongation nor the development of the entablature, upon which they rest as a hat would, without being an integral part of it. The profiles of the moulding are very simple, and resemble archaic Greek make rather than the soft, undulating outlines of Græco-Roman structures, found in plenty throughout the southern districts of the peninsula. Thus in the tomb which, beyond all others of this series, has been most minutely described, we find as terminal moulding at the sides of the frontal, a deeply inclined but rude form, with none of the characteristics of a Greek

¹ M. Ramsay has handed to me a drawing of another rock-cut façade, in which chevrons likewise encircle the arch.

² PLACE, *Ninive et l'Assyrie*, Plate XL.; *Hist. of Art*, tom. ii. Figs. 76, 155, 156, 190.

³ *Hist. of Art*, tom. iv. Fig. 314.

cyma ; whilst the entablature of all these frontispieces sins against canonical proportions.

But we find its counterpart, or nearly so, at Persepolis, where, as

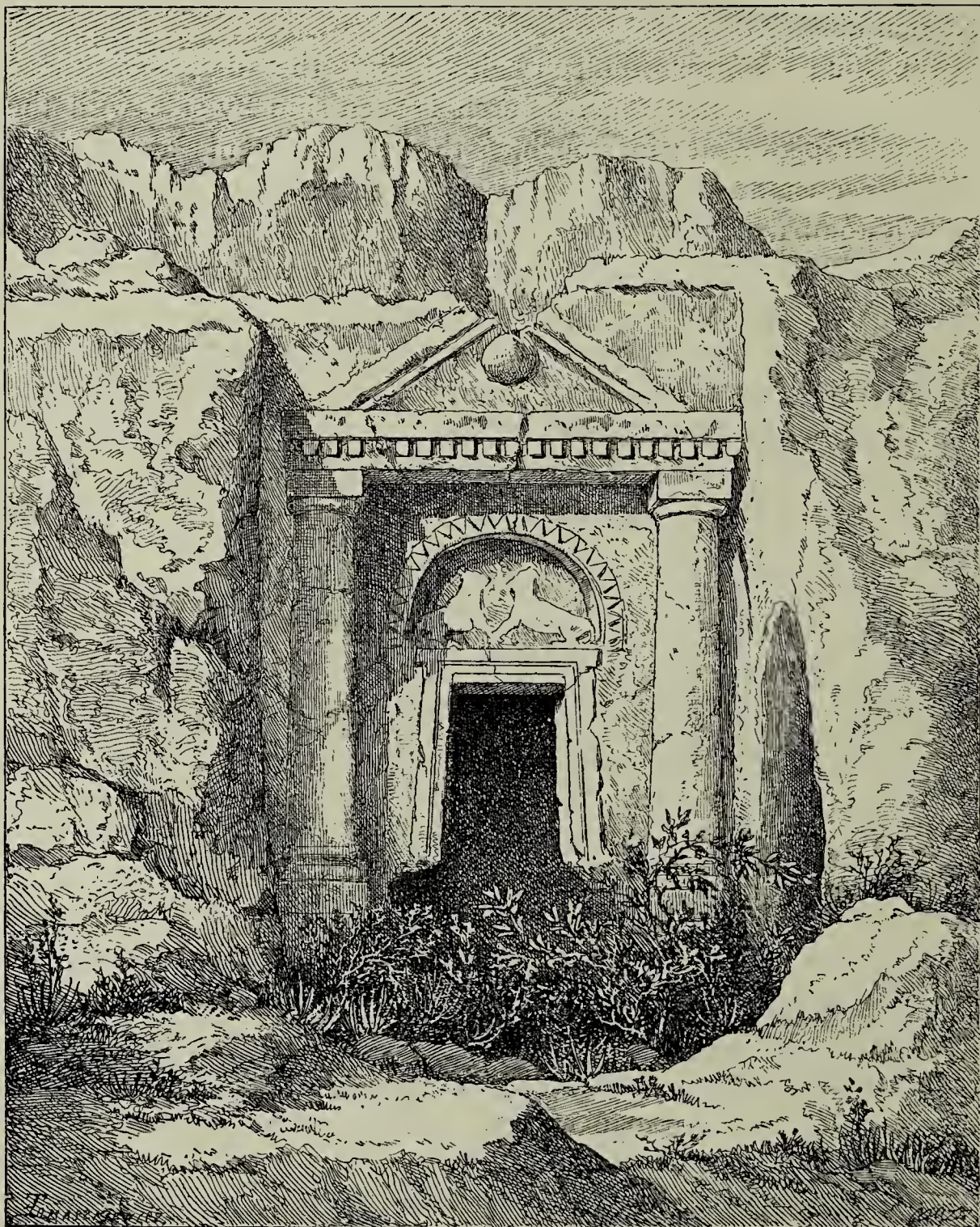

FIG. 92.—Tomb at Ayazeen. *Journal Hell. Studies*, 1882, Plate XXVIII.

in Phrygia, the architraved cornice is never seen without a row of dentels under the corona of the frontal. The same remark applies to the rock-cut columns, every one of which has points in common with one or other of the types which constitute classical architec-

ture, but so divergent in many respects as to preclude being classed in a distinct order. In one of these tombs (Fig. 92) the capital

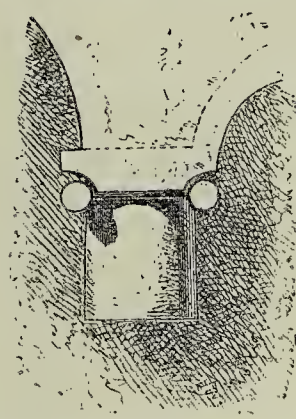
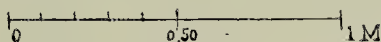
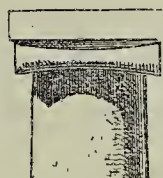
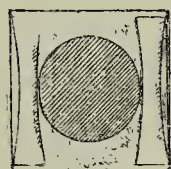
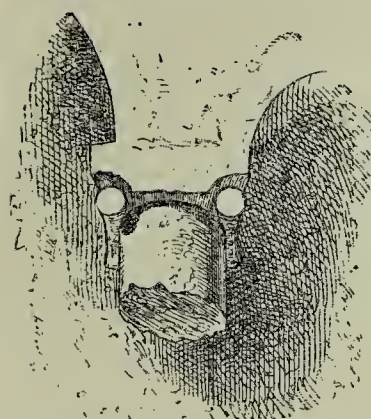

FIG. 93. —Ionic capital. Present state. Perspective view. *Journal*, 1882, Plate XXIX.

FIG. 94. —Ionic capital. Plan. *Journal*, Plate XXIX.

FIG. 95. —Ionic capital. Lateral elevation. *Journal*, Plate XXIX.

FIG. 96. —Ionic capital. Elevation. *Journal*, Plate XXIX.

is composed of two members, which play the part of the echinus and abacus in the Doric capital. The result of this is that it somewhat resembles the latter; the contour, however, is different, and the somewhat slender column rests upon a base. In another tomb (Fig. 82), the capital is formed of two thin rolls, with so deep an inward curve as to be separated from the abacus found at the springing of the arch (Fig. 93). The interest which attaches to this capital, both in plan (Fig. 94), side view (Fig. 95), and elevation (Fig. 96) is our reason for reproducing it. In principle the motive is the same as in the Ionic capital; but how wide the difference between the dryness of these cushions and the elegance and amplitude of the volute! Again, we are reminded of the Corinthian capital (Fig. 97) in the calathiform of Fig. 77,¹ with its ring of leaves under the lower part; save that

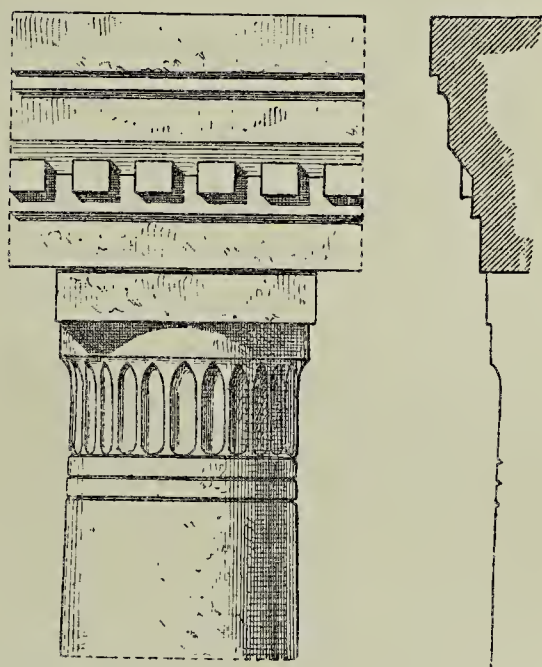

FIG. 97. —Calathiform capital and profile of shaft and entablature. *Journal*, Plate XXIX.

¹ Some kind of likeness exists between this Phrygian capital and that of a tomb near Mylassa, in Caria, which Téxier was inclined to date from the Roman dominion (*Asie Mineure*, 8vo, p. 648, Plate XXVII.). There is no doubt about the forms enfolding the Carian capital being acanthus leaves, whilst the influence they betray

the latter are sketchy, without salience, and barely outlined. They are more developed and their characteristics are better brought out in the pilaster of the Broken Tomb, in which a colossal lion

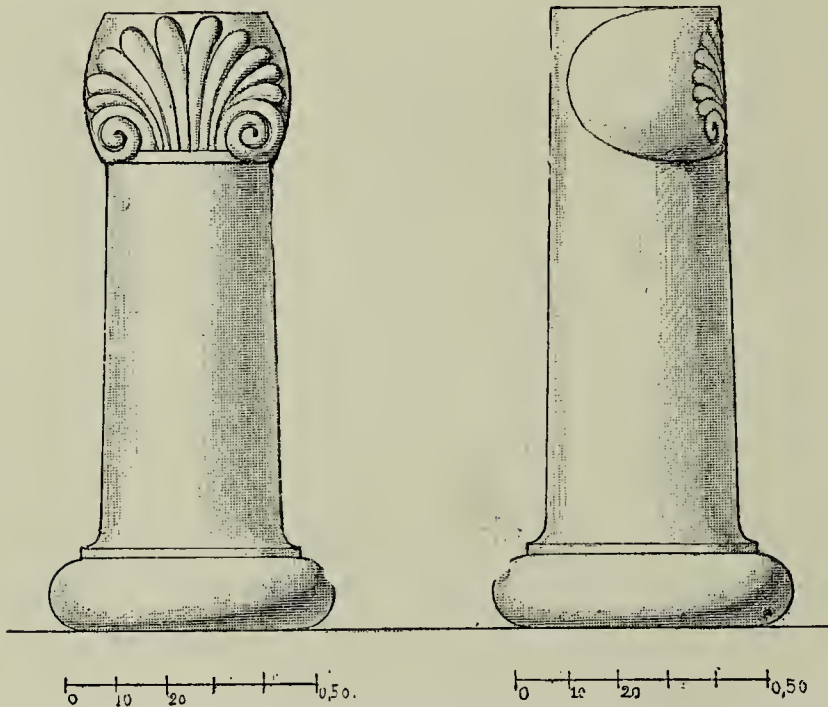

FIG. 98.—Elevation and profile of pilaster in Broken Tomb.
Drawn by Ramsay.

appears (Figs. 98, 99). Here also the base of the column is not unlike the Ionic, whilst the terminal palmette is akin to that which expands above the volute of certain stelas figured on Greek vases.¹

On the other hand, the palmette in question bears just as much analogy to that which

crowns a stela discovered in Assyria, at Khorsabad, by M. Place.²

How great the embarrassment of the scholar who enters upon the study of Phrygian architecture, will be easily understood. Thus, many a detail looks as the dawn and harbinger of Greece; many another is only to be explained by the light and traditions of Asianic culture, and one pauses before not a few to which either origin might be assigned at will. The characteristic touch which more

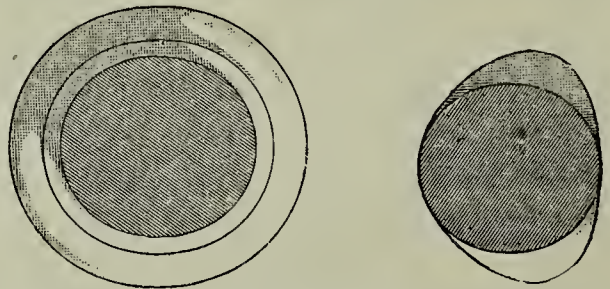

FIG. 99.—Pilaster of Broken Tomb. Plan above base. Plan at the commencement of capital.
Drawn by Ramsay.

to Greek models is no less certain. The blocking out, however, before the ornament was proceeded with, must have offered a mass very similar to that of the Phrygian capital. The basket-shape was in full swing during the rock-cut stage of architecture, and no doubt continued in the habits of the native artisan, even when he had learnt how to dress stone and fashion the capitals and shafts of his columns out of the same material.

¹ CHARLES CHIPIEZ, *Hist. critique des origines de la formation des ordres grecs*, p. 273, Fig. 130.

² *Hist. of Art*, tom. ii. p. 270, Fig. 110

than any other betrays the relationship these monuments bear to those of Cappadocia, and through these to the art of Assyria and Chaldæa, is the feeble salience of the sculptures seen on these façades. The geometrical, vegetable, animal, and human shapes which adorn the doorways, tympan, and frontals of these frontispieces, with rare exceptions, are chiselled in flat relief and all the living forms drawn in profile. The processes by which they were obtained are precisely similar to those of the figured decorations encountered beyond the Halys, the Taurus range, and the valley of the Amanus, works which we ranged under the denomination of Hittite monuments.

Among all these façades, that in which the highest and boldest relief was attained by the Phrygian sculptor is the Kumbet tomb (Fig. 84). The heads of the lions and the vase stand out from the field with a relief of thirteen centimetres and seven centimetres respectively. This furnishes us with a first token that the monument is younger than many others in these necropoles; its outward appearance, however, is not as thoroughly Greek as Gherdek Kaiasi, for instance; it still belongs to the transition period, and must be ascribed to native art. The themes treated by the sculptor are those selected in preference by the Syro-Cappadocian ornamentist. Such would be eagles and lions figured in pairs face to face, a phallus, a tree, vase, or candelabrum interposing between them, and likewise encountered on many a point of Phrygia. This same subject (animals in pairs) appears on the cylinders and sculptures of Mesopotamia, as also in Cappadocia; whilst Phrygian tombs are witnesses to the special favour it enjoyed with the indigenous artificers, whether on the threshold or above the entrance to their hypogees. But if the data are very primitive and archaic, the technique denotes a more advanced stage and a later date. Compare the Kumbet lions with the Kalaba example¹—also due perhaps to Phrygian activity—and those of Figs. 64, 65, met with in the necropolis under consideration, and you will perceive at a glance the wide-reaching distance which divides them.

When the artist set about chiselling the Kumbet animals in the rocky mass, he had freed himself from the conventionalism resorted to by his predecessors for indicating the hair, the muscles of the fore-leg and the shoulders. This is very visible in the model-

¹ *Hist. of Art*, tom. iv. p. 713, Fig. 350.

ling, at once bolder, rounder, and smoother ; but its commonplace facility does not compensate for the loss the work has sustained in dignity and vigour. As was observed a few pages back, the shape of the double-handled vase, which occupies the centre of the field, is both simple and elegant, and its contour may be seen in countless Italo-Greek specimens deposited in our museums. Hellenic influence is, perhaps, even more apparent in the architectural domain. False openings, as at Delikli Tach, with cumbrous jambs in retreat one upon the other, and no less massive lintels, have disappeared ; in their stead are real doors, with frames less refined, but which none the less recall those of Hellenic portals. True, this likewise occurs in the Ayazeen necropolis ; but the bay of these façades (Figs. 64–67) tends to narrow above and widen below, and by inference this is at least a sign, a presumption, of relative antiquity. The fact that the jambs at Kumbet are straight leads one to believe that the models from which Phrygian art drew its inspirations had stepped beyond the archaic period. The same impression is left by observation of the entablature. Not only is it quite distinct from that of the oldest façades—those bearing Phrygian inscriptions—it is also more complex, and shows greater skill and technique in its elaboration, than in those tombs wherein trapezoidal doors obtain. Over the entablature in question was a real cornice, the deep salience of which is cause of its almost complete destruction, making it a matter of conjecture as to the nature of the profile and the moulding composing it. Had it been preserved we should, in all likelihood, find in it all the essentials of a Greek cornice, with something of the light and shade which are never absent from Hellenic compositions. What confirms our conjecture is the arrangement of the sides of the pediment. They consist of members largely introduced in classical architecture, and appear in the same situation, the same order, and almost the same proportions. Thus dentels and modillions are figured under and above the corona respectively. Over it again stands out a cyma, and terminal palmettes, corresponding to the antefixes of Greek frontals, unfold at the angles and the apex of the pediment. In Greek taste, too, averse to monotony, are those small heads between modillions, sculptured on the soffits, which appear to have yielded great variety of types.

Despite these and other resemblances, the Kumbet tomb is not yet a thorough-going Hellenic work ; the proportions of its

façade are not those which would have commended themselves to an Ionian architect called in from Phocæa or Ephesus. The modillions have a breadth, shape, and relief unknown to Greek modules, and the angle of the pediment is more acute than in classic buildings. There are no columns; the very peculiar cornice belongs to no distinct order, and in some respects it still recalls a primitive wooden construction.

The inference to be deduced from analysis and comparison alike is that the monuments we have just passed in review form a continuous series, without break or discrepancy. We are led by almost imperceptible stages from those of unquestionable hoary antiquity on to exemplars which testify to the inroads Grecian art was making in the inland districts of the peninsula, foreshadowing its final and complete victory. Hence, it behoves us to guard against a conjecture, apt to arise in the mind of the archæologist by superficial and hasty inspection of the façades under consideration. Many a tomb of Caria, Pamphylia, and Lycia displays forms which at first startle the student by their seeming strangeness, but when dissected and examined in detail, they turn out to be nothing more than Greek shapes, the poor or clumsy style of which is due to imperfect technique, local habits, or corrupted taste. Thus, about this and that structure one had been inclined to think very old there crops up a characteristic feature, a dated inscription which discloses the fact of its being the work of the decadence, of the second or third century A.D.

In like manner, there is danger of antedating, doubts are felt, in regard to a number of monuments of the Ayazeen necropolis. Similar doubts we think we have forestalled. Here, in this district where the old Phrygian kingdom had its political and religious centre, all the monuments explorers have disinterred or reported are certainly the fruit of a primitive national art. The difference between them resides in the fact that some travel back to the age when this art created types and adopted processes of its own, whilst others belong to the period when, unwillingly and whilst disputing the ground step by step, it began to yield to the greater charms continental Greece was offering to her neighbours. The monuments embraced within the period which has the Midas rock at one end and the Kumbet tomb at the other, the older as the more recent, are all prior to the triumph of Hellenic genius—a triumph which, prepared by the conquests of

Alexander, took a long time in gaining a foothold in the more distant provinces of Asia Minor, and was finally completed by the proconsuls, prætors, and procurators of Rome, when the whole country, swampy steppes and hilly range, was intersected by military routes. In taking up, then, monuments so very much later than the fall and consequent loss of independence of the Phrygian kingdom, we have not outstepped the limits within which must be confined this part of our History of Art. Study of the little that remains of their fortresses and sanctuaries will bring out with even greater force and vividness the truly archaic and original character of the civilization under notice.

RELIGIOUS ARCHITECTURE.

Neither in Phrygia nor Cappadocia are found traces of temples constructed with a view of placing in them the image of the deity. But as in Pterium, here also, sanctuaries and fortresses, steps

leading to them, sacrificial altars, along with the divine simulacrum, to which was addressed the homage of the multitude, seem to have been wholly rock-cut.

The more important of these sanctuaries are open to the sky; but it seems not improbable that temples, or, to be accurate, subterranean chapels, also obtained.

There is reason, we think, to recognize as places of worship a certain class of monuments which at the outset were supposed to be

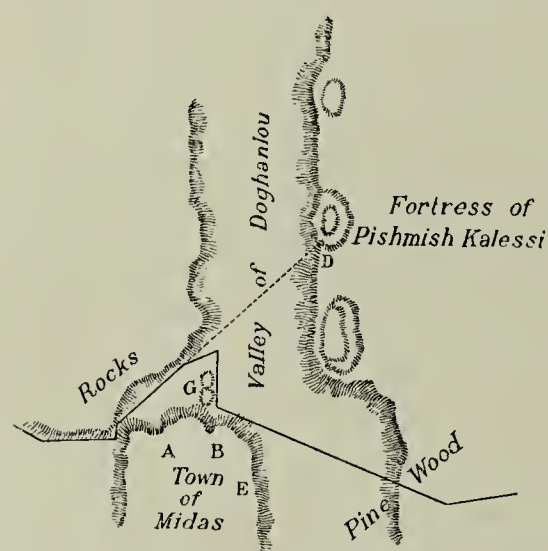

FIG. 100.—Valley of Doghanlou and town of Midas. *Explor. Arché.*, "Itinéraires," Feuille C.¹

tombs, but in which dispositions appear ill in accord with the hypothesis of a sepulchral function.

Thus southward of the ravine locally called Doghanlou Deresi (the Hawk Valley) shoot up broad masses of rock bounded by a perpendicular cliff, in the depth of which monumental façades, akin to that bearing the name of Midas, have been cut (Fig. 100).

¹ Legend of map: A, tomb figured by T  xier, Plate LVIII.; B, Midas monument; C, masses of rock honeycombed with graves; D, tomb (Fig. 72); L, other tombs (Fig. 123).

The stony mass terminates in an oblong plateau dipping southward, where may be traced surfaces levelled out with care, stairways, altars, a variety of symbols, inscriptions, rock-cut walls, perhaps the back walls of houses leaning against the cliff.¹ The esplanade was formerly surrounded by a built wall, the blocks of which have almost all disappeared; but the marks left in the tufa by the lower units may still be traced. This fortified level is what M. Ramsay has called the "Midas town." It was reached by a path, like-

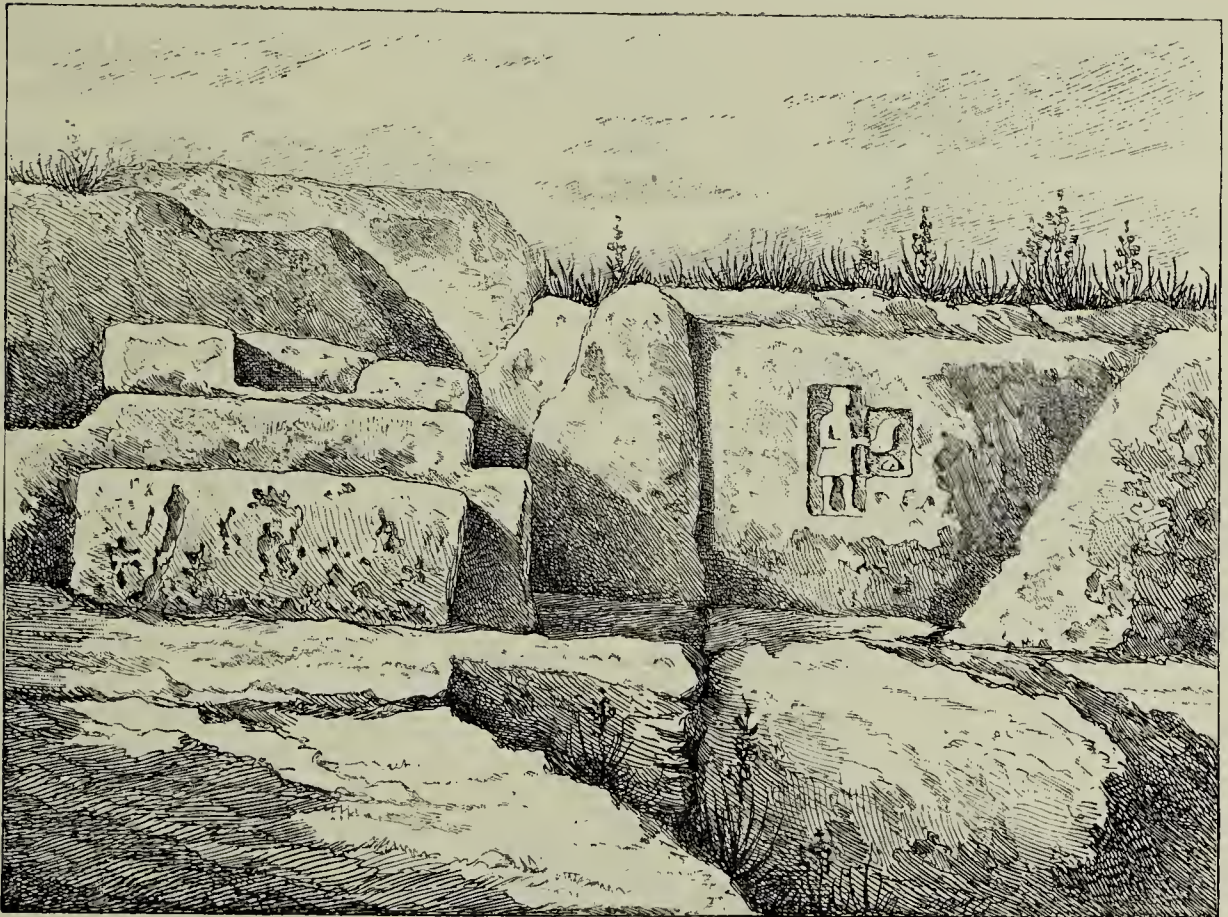

FIG. 101.—Rock-cut altar and bas-relief. *Journal*, Plate XXI.

wise rock-cut, which took its start about two hundred metres south of the Midas rock, and ascended in a gentle curve from the valley, having on the right a vertical wall of rock, on which a series of eight figures in flat relief have been carved, as if to represent a procession descending from the heights towards the valley

¹ I and M. Guillaume did not visit this plateau; hence our map (Fig. 100) contains but a general outline of the northern portion of the cliff. The account which follows is borrowed from M. Ramsay, to whom redounds the honour of having discovered this group of monuments (*Hellenic Studies*, vol. iii. pp. 6-17, and 41-44, under the title: "Studies in Asia Minor"). But he made no plan of the unit, and did not attempt to give a methodical and complete description of it. His information respecting it has to be gleaned and sought out in various papers.

below. Each and all are very much worn, and the drawings by which they are known are not sufficiently minute or exact to allow us to define their style.¹ Until further details are to hand, therefore, they cannot be considered as works executed by the subjects of the Gordioses and Midases. Some thirty yards beyond, just before reaching the summit, the road widens, and there appears straight before you a sculpture representing a personage clad in

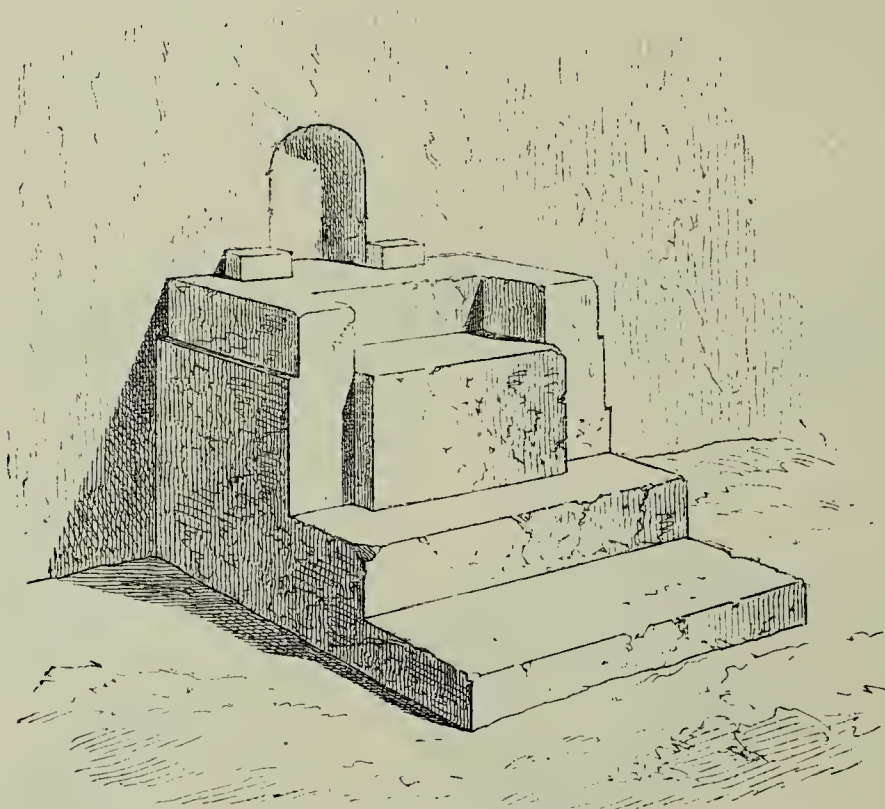

FIG. 102.—Rock-cut altar.

a short tunic, and grasping a kind of sceptre in his left hand, and hard by a huge two - stepped altar cut in the living rock (Fig. 101, 10 in map). The high antiquity of the figure is unquestionable; in front of it we recognized signs of the Hittite writing; and this obliged

us, so to speak, to class the bas-relief in the series of monuments of Syro-Cappadocian art.² In so doing there was no intention on our part to detach it from the group to which it by rights belongs; our aim was simply to make the sequence of figures associated with ideographic characters as complete as possible. This system of ideographs preceded in Asia Minor the introduction of alphabets derived from the Phœnician syllabary. Both altar and bas-relief were fashioned by the same hand. The latter represented one of the tutelary gods, under whose protection the small Phrygian city was placed. Close at hand was a stone table or shelf, upon which offerings were laid. The place constituted what may be termed the temple-gate,

¹ RAMSAY, *Hell. Studies*, "Studies in Asia Minor," Figs. 1, 2.

² *Hist. of Art*, tom. iv. pp. 721, 722, Fig. 363.

where preliminary devotions were performed ere the precincts were entered.¹

Traces of high places, sanctuaries open to the sky, abound on the plateau and several points of this district; of which half a dozen or so, borrowed from M. Ramsay, are reproduced here. A ledge and a niche occur above the altar of the first of these (Fig. 102); the latter was meant, perhaps, to receive a lamp or a statuette, and might be taken for the altar of a Roman Catholic chapel. *Per contra*, the terminal form of the altars (Figs. 103²—105) is

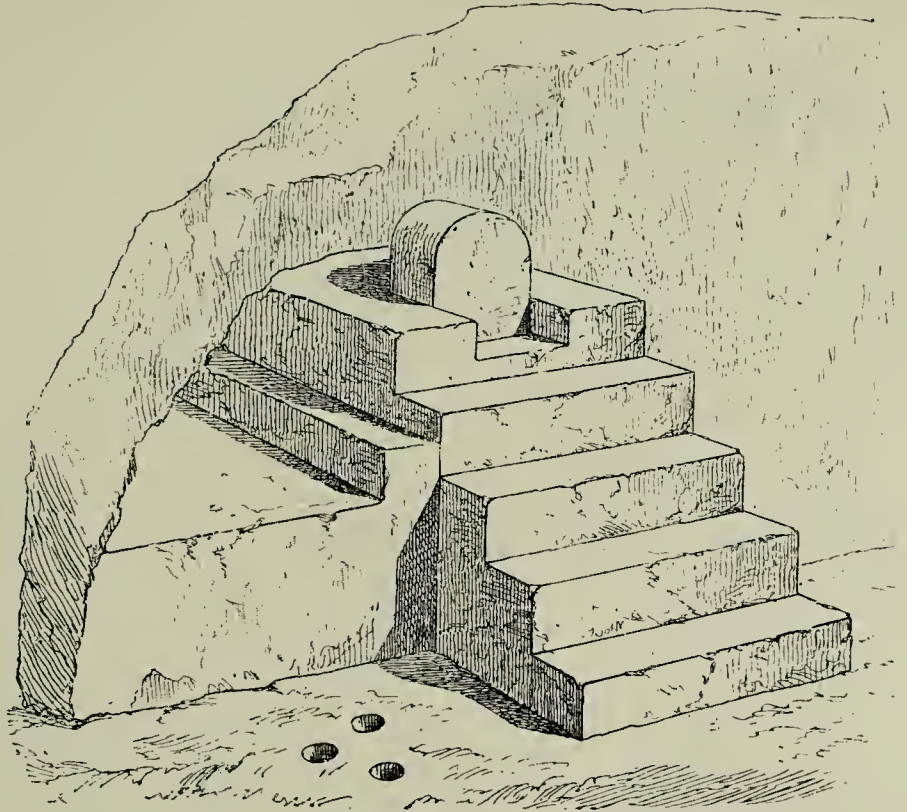

FIG. 103.—Rock-cut altar.

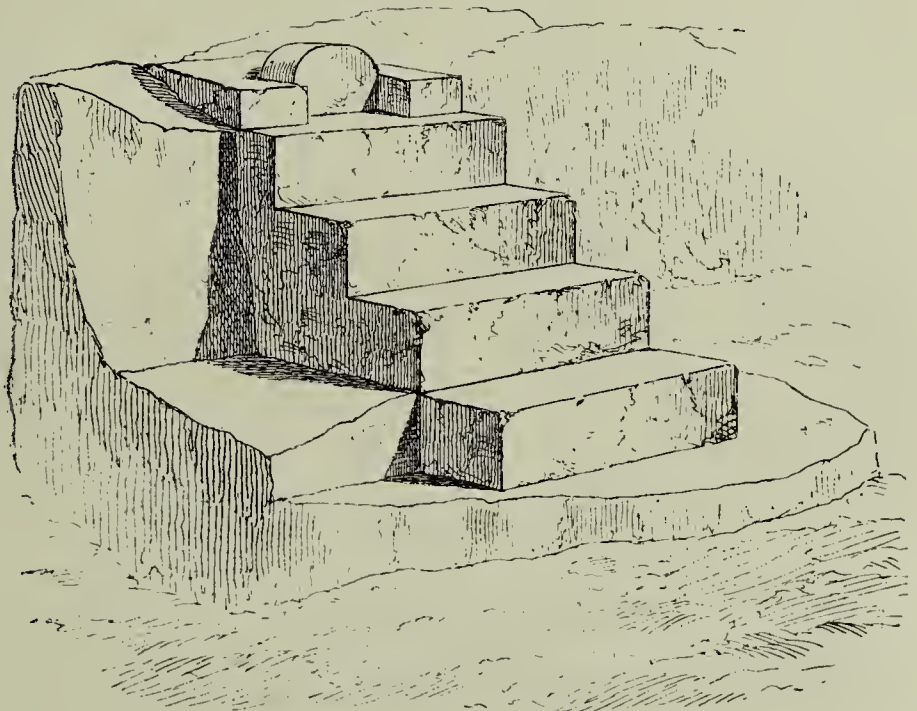

FIG. 104.—Rock-cut altar.

¹ M. Ramsay at first mistook the sinking which may be seen behind the altar for a mortuary bed. But on a subsequent visit he discovered that what he had taken for a funereal trough was in reality a grave made to receive the stones of the lower course (*Hell. Studies*, p. 11).

² The boetulus and the lower steps of this altar are broken away.

a kind of milestone rounded at the top, seemingly of the nature of a *boëtulus*, sacred stone. That which justifies us in attributing

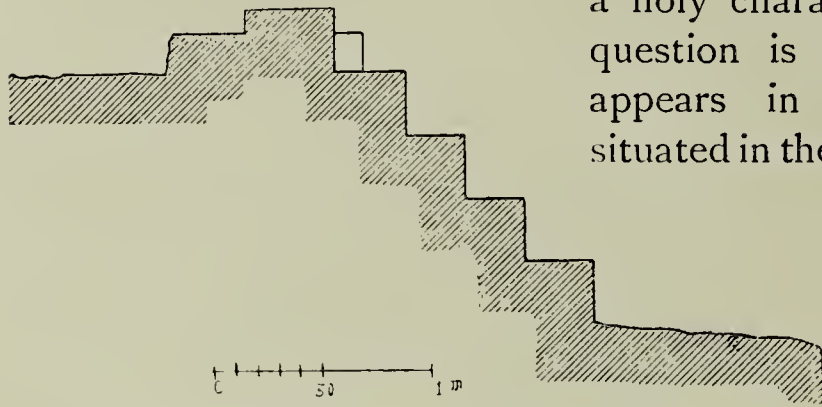

FIG. 105.—Rock-cut altar. Section through axis.

a holy character to the stone in question is the fact that it reappears in another monument situated in the centre of this plateau (Fig. 106, 11 in map), whose rude ornamentation allows us to guess its true import; this appears in the shape

of two concentric circles or discs carved side by side on the



FIG. 106.—Rock-cut altar. From drawing and photograph of Ramsay.

stela. The curved lines enframing them, which terminate on each side in a curl, bring to mind the head-dress of the Egyptian Hathor,¹ an arrangement we observed in Asia Minor in the

¹ *Hist. of Art*, tom. i. Figs. 40, 342, 343.

monuments of Hittite art, both about the sphinxes at Eyuk,¹ and the colossal figures of the façade at Eflatoun.² Curve and ringlet, turned outwardly at the end, are identical in all.

Finally, to complete the series, we will cite a last monument, a shrine found on the rim of the plateau, right over the path which leads to it. The surface of the stela is dressed with care, but void of ornament. On the other hand, close by, on another part of the rock, is a figure which, despite its diminutive size and roughness of make, at once reminded M. Ramsay of the

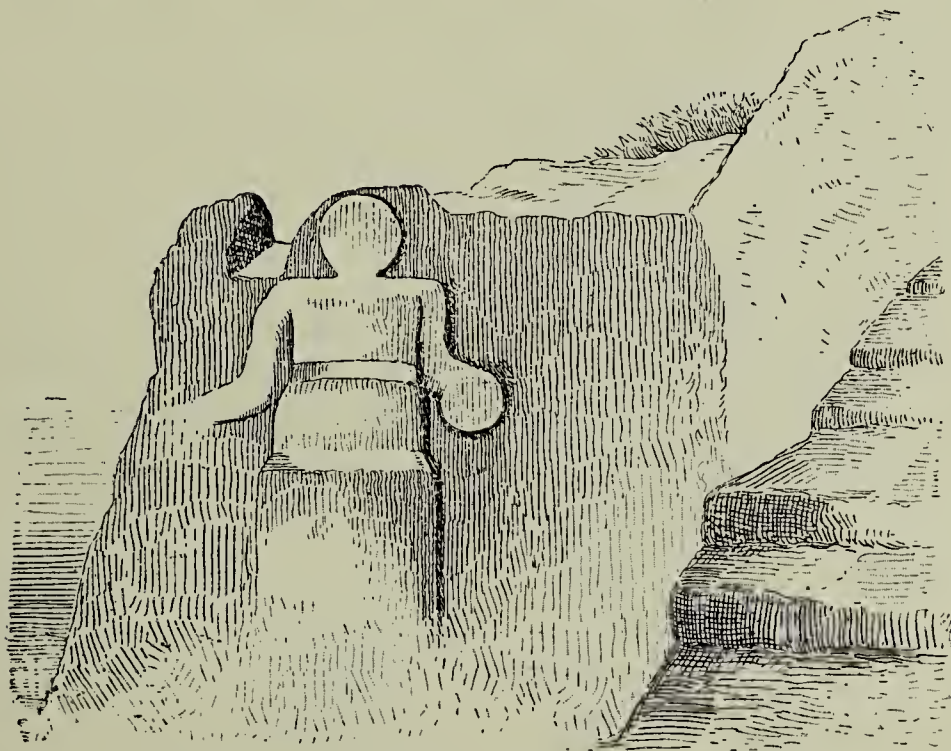

FIG. 107.—Figure of Cybele. *Journal*, 1882, Plate XLII.

colossal Cybele on Sipylus (Fig. 107, 11 in map). Seen full face, the pose is that of a sitting figure, for the knees stand out 10 c. from the body. The right hand has disappeared, but in the left is carried a shallow bowl (*phiale*), the one attribute most sedulously preserved in Grecian art to the Asiatic goddess. That this picture was intended as a representation of Cybele is confirmed by the inscription MATAP KTBIAE, to be read over a pedestal of the same nature in the necropolis of Ayazeen (18 in map). In this figure, which we recognize as Cybele, the features, as on the stela just described, are not indicated, and the head is a mere round ball. This same conventional treatment of the divine

¹ *Hist. of Art*, tom. iv. Figs. 323, 327.

² *Ibid.*, tom. iv. p. 737.

simulacrum was repeated on the sacred stone, where, the better to emphasize the meaning, the hair was added.

The Phœnicians now and again made use of this very same abridged process for those stelas which Carthage manufactured in prodigious numbers; where Tanith is figured, now standing, now reduced to a mere bust, whilst at other times the divine representation is reduced to a head wreathed in plaits of hair arranged as those of our Cybele.¹ The whole difference consists in this, that whilst the superior skill of the Phœnician sculptor enabled him to chalk in with a few strokes nose, eyes, chin, etc., his Phrygian colleague suppressed every detail and carried simplification to its utmost limits.

Are the two heads (Fig. 106) figured on the stela emblematic of the worship rendered here to twin paredre deities, or is the repetition intended to convey the notion of the power of one and the same divine personage? The answer to this query might perchance be had, could the Phrygian inscription of two lines incised on the wall dominating the sacred stone be read.² No translation of the text, however, has yet been made, and, moreover, it seems pretty certain that we possess but the half, and that other two lines were protracted on the right-hand side of the stela. But all this part of the monument has been detached by an earthquake or the action of the weather. One side being intact, it would be an easy matter to restore the other. In its original state the monument, though simple, was not void of a certain degree of dignity.

In some respects these hypæthral shrines recall the high places of Syria and Palestine;³ they differ from them in that neither stone altar nor *bœtulus* were left in the rough, but have been fashioned by metal implements. The Phrygians do not seem to have been imbued with the notion that contact with forged iron would pollute the stone and rob it of its sacred character. Hence they freely used pick and chisel to excavate small temples, akin to the Egyptian *speos*, close by these open places of worship. It is a sanctuary

¹ *Hist. of Art*, tom. iii. Fig. 16.

² Consult RAMSAY, *On the Early Historical Relations*, Plate I. n. 6, p. 33.

³ *Hist. of Art*, tom. iv. pp. 371, 372, 375-385.

We are all familiar with the following passages:—"So Moses commanded the children of Israel to build an altar of whole stones, over which no man hath lifted up an iron." Again: "Thou shalt not lift up any iron tool upon them," *e.g.* stones to build an altar.—TRS.

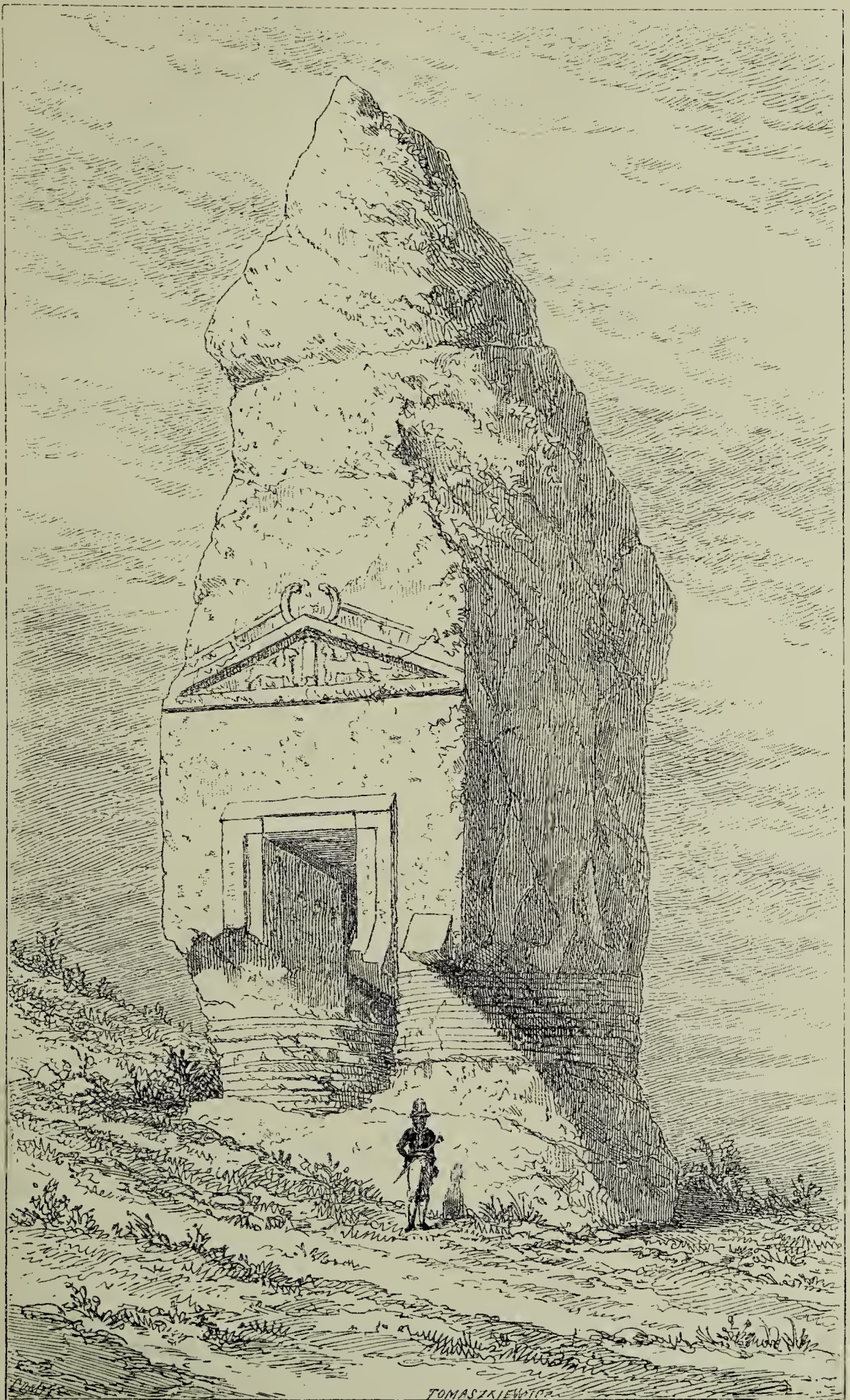

FIG. 108.—Arslan Kaia. General view. *Journal of Hellenic Studies*, 1884, Plate XLIV.

of this kind that we propose to recognize in a monument which, at first sight, the traveller who discovered it placed among funereal hypogea.

This monument—unfortunately much injured—is hard by the village of Liyen (Fig. 108, 13 in map) and goes by the name of Arslan Kaia (the Lion Rock). The physical formation here is a stratified tufa of varying degrees of hardness; some layers are quite soft, and the sculpture is not protected against the weather by overhanging rocks. Arslan Kaia is cut in the face of a tall isolated rock, of sugar-loaf shape, which rises to the height of some twenty metres on a steep grassy slope.¹

The rocky mass has been chiselled on three sides, so as to present three vertical faces, looking respectively east, south, and west. The southern side is the most important. It forms a rectangular surface, in the lower part of which the door is pierced, topped by a pediment crowned by a curvilinear device, analogous to that of the Midas monument. Here, however, it seems to terminate in two serpents' heads. The inner slab was formerly covered with geometric shapes, of the nature of those so well preserved at Iasili Kaia—meanders and crosses, but so defaced that an occasional fragment is all that can be made out; so that no attempt has been made to indicate them in the annexed woodcut (Fig. 109). There is also a Phrygian inscription along the horizontal fascia that divides the triangular pediment from the rectangle or inner slab, but so hopelessly obliterated that it could not be transcribed with any hope of success, even when brought close to it by a ladder.² The decoration of the frontal, thanks to the salience of its sloping beams, is in a better state of preservation. It is composed of two winged sphinxes, passant and face to face, but separated by the supporting column. They are seen in profile, their heads turned towards the spectator, the ears large and prominent, but the features are worn quite flat. A long curl hangs down over the shoulder of each. A band of meander pattern runs along the two sloping sides of the pediment. The whole is carved in very low relief.

¹ Our views of the monument have been obtained from M. Ramsay's sketches, which, he observes, "were confined to the wrought part of the stone, and that the draughtsman made them too high, causing the rock to look taller than reality" (*Journal*, Plate XLIV. ; *ibid.*, 1884, p. 241).

² *Ibid.*, p. 243, n. 2.

The eastern face of the monument is entirely taken up by a huge rampant lion. He stands on his hind legs, and his fore paws rest on the angle of the pediment; the head, almost disappeared, towered high above it. The lower part of the figure is in better condition. It would be natural to find his pendant on the other side, and no little surprise is felt in meeting in his stead a diminutive figure of different type and movement. It is a passant griffin, much injured, whose head faces eastward, and probably

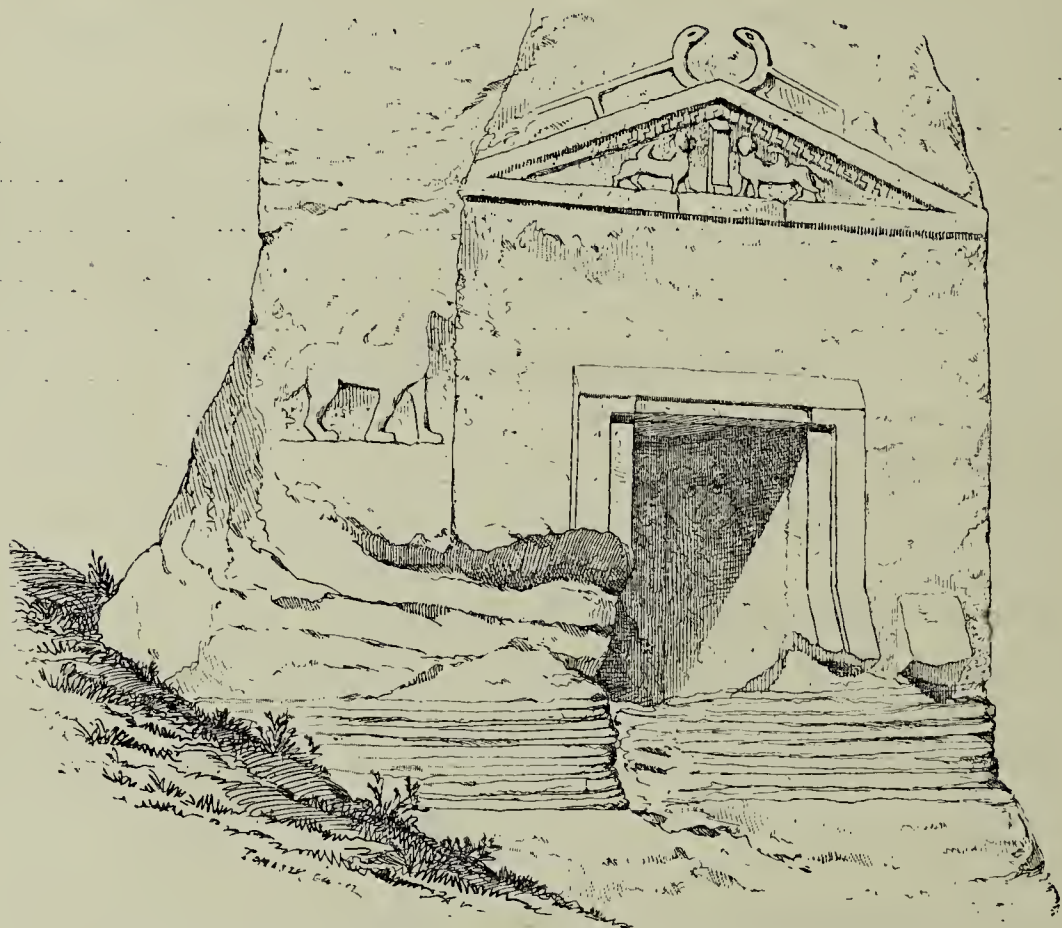

FIG. 109.—Arslan Kaia. Western side. *Journal*, Plate XLIV.

ended in an eagle's beak like those of Assyria, which may have served as models (Fig. 109). Griffins and sphinxes alike have the tips of their wings outwardly curved in the form of a round knot.

Our journey round the monument has brought us back to the main face in which the door is pierced; the disposition of this recalls the simulated openings at Delikli Tach and Iasili Kaia. In the present case, however, we are confronted by a real bay; one, too, intended to be always open. The two wings of the door are figured in relief against the sides of the little chamber into which

the door gives admittance. On each valve of the door, near the top, is a row of nails which served to fix a bronze lining. On the right wing is a defaced ornament, which may be a lock, or possibly a knocker. The door gives access to a little rectangular chamber, whose end wall is taken up by a very curious sculpture (Fig. 110). It represents two lionesses who stand on their hind legs, face to face, and rest their fore-paws against the head of a central figure, in which, despite its dilapidated state, we recognize a woman wrapped in long drapery, with a tall ovoid tiara upon her head.

This woman can only be a goddess, and that goddess Cybele, the great local deity, whom lionesses she has tamed surround in playful attitude, and in whose company she travelled round the ancient world. The image was carved in relief fully a foot high, but the soft volcanic tufa was unsuited for a relief standing out so boldly, and the front part has fallen off, leaving only an uneven surface with the outline of the figure.

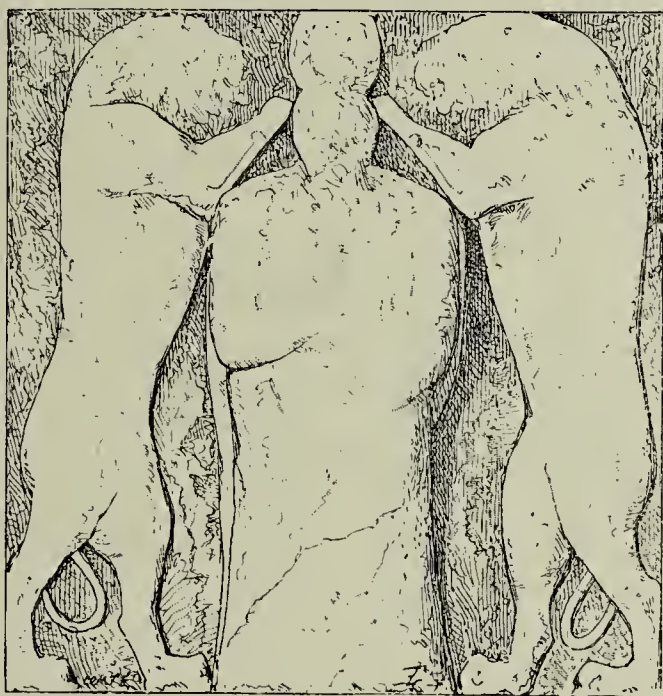

FIG. 110.—Arslan Kaia. Sculpture on the end wall of chamber. *Journal*, 1884, p. 285.

The movement of the arms, however, can be made out from the difference of the angles at the elbows. The right hand, it would seem, was placed over the bosom, and the left hand over the middle—an attitude rendered familiar to us from scores of simulacra of Asiatic goddesses.¹

Had the stone in this district been more compact, we should, doubtless, find many another instance of this type. Thus, near the fine tomb already described (Fig. 64) a similar idol, albeit even more defaced, ruder and smaller than this, stands in a little niche three metres high (Fig. 111).²

It will be understood, therefore, that if we left out from among the number of tombs the hypogeum of Arslan Kaia, it was because nothing about it betrays a funereal purpose. Every sepulture, in

¹ *Hist. of Art*, tom. iii. Figs. 381, 382.

² RAMSAY, *Hellenic Studies*, vol. v. p. 245.

view of the function it is called upon to fulfil, must be closed. We have seen what precautions were taken in the oldest Phrygian sepulchres to ensure the repose of the dead. The grave-chamber was made inaccessible save by a shaft, which, being on the summit of a lofty rocky mass, could be easily concealed under a clod of earth or brushwood. In all those instances where the tomb was entered by a real door, we mostly find the grooves in which fitted the covering slab. Here, however, not only is there not the slightest trace of closing, but the wings of the door are

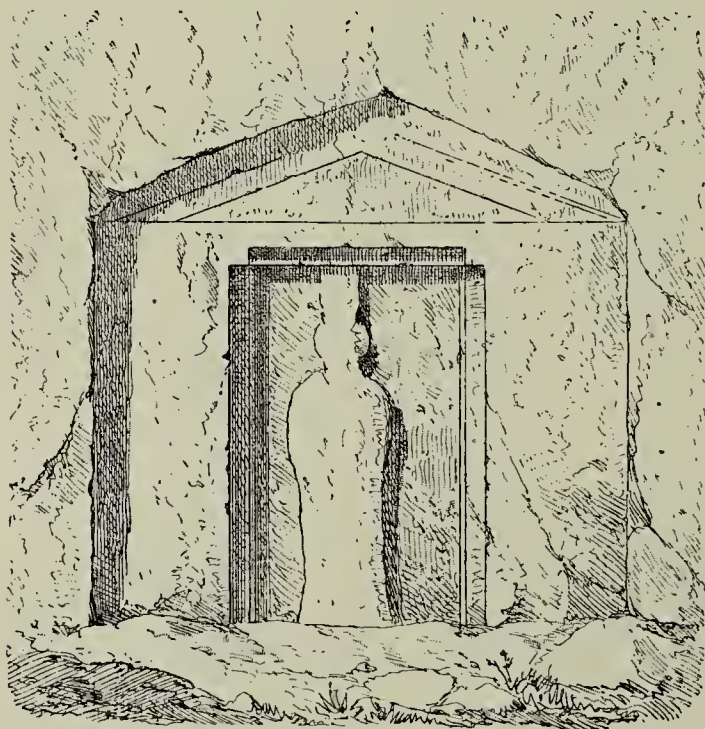

FIG. 111.—Niche, with figure of Cybele.
After Ramsay.

actually figured thrown back against the wall: a disposition which, if ill suited to a sepulchre, is quite appropriate to a sanctuary. If we pass through the bay, which seems to have been invitingly left open, so as to attract the wayfarer to penetrate into the chamber, we shall find in it neither troughs, niches, nor couches scooped in the floor or let into the walls; but facing us is an image whose religious character is unquestion-

able. Will it be urged that the goddess whom we see carved on the wall appears here as patroness of the dead and guardian of his eternal repose? But naught like it is met with in those chambers that leave no doubt as to their funereal purpose. Moreover, there are no data, figured or literary, to induce the belief that Cybele ever filled the office of sovereign of the nether world, custodian of the departed.

From all appearance, therefore, the Arslan Kaia chamber is akin to those subterranean sanctuaries we have studied in Egypt,¹ Phœnicia,² and Arabia,³ as well as those we shall find in

¹ *Hist. of Art*, tom. i. pp. 408, 409-427, Figs. 234-249.

² *Ibid.*, tom. iii. pp. 258-261, Fig. 197.

³ *Ibid.*, tom. iv. p. 389, Fig. 204.

Greece, where, as a rule, they were dedicated to Pan and the nymphs. We should also be inclined to consider the smaller artificial grotto contiguous to the Midas tomb (Fig. 48) in the light of a chapel, or shrine, in which traditional rites were performed in honour of the ancestral god, to whose memory was consecrated the imposing façade bearing his name and titles. Indeed, the whole district we have just gone through is brimful of similar rock-cuttings, which like dark patches dot the face of the rock along the roadside. Here offerings were deposited, according to the locality, either to ancestral gods, manes, or national deities. The Phrygian workman was not content with chiselling the image of his gods in the solid rock, cutting altars, excavating sanctuaries and grave-chambers in which the bodies were laid; he likewise provided places of refuge for the rural population who, along with their live stock, lived in straggling homesteads in the clear portions of the forest. Fastnesses were needed, and everywhere the relief of the soil offered capital defensive positions. The more gentle slopes were turned into perpendicular walls, and rendered inaccessible by engineering; stairways, parapets, fortified posts, everything was obtained from the stony mass, which, with the stone-cutter, became as soft as clay in the potter's hand.

MILITARY ARCHITECTURE.

There are numerous hillocks in this district to which the natives give the name of Kaleh. (fortress). In fact, on the sites thus denominated rise Gheugheuz Kaleh, Doghanlou Kaleh (in map), Tshukurja Kaleh (14 in map), Aktshe Kaleh, and many more; each and all exhibiting traces of the hand of man, and of his having been stationed here.¹ Of these (the castle of Pishmish Kaleh, Burnt Fortress) may be taken as type of the class (Fig. 100).² It occupies the summit of a rectangular mass, terminating in a kind of table upheld by almost perpendicular rocks (Fig. 112). The lower belt of the hill is covered with vegetation, but above it the sides are so rugged and precipitous as to require a long détour to reach the top. At first, the rock, with its grades almost up to the summit,

¹ Aktshe Kaleh (Silver Fortress) is not marked on Ramsay's map. From my notes, it should be to the northward of Pishmish Kaleh, a little way beyond it.

² PERROT and GUILLAUME, *Explor.*, pp. 145, 169, 170.

looks like a Byzantine castle;¹ and as you ascend the winding path there appears a chasm in the hillside, bridged over with characterless materials—baked bricks, squared stones, chips of all sizes and shapes, fixed in beds of mortar. But the aspect of man's work completely changes as you reach the other side, more particularly the plateau. This has been levelled out, save towards the centre, where the rugosity of the tufa is so slight as to render it unnecessary. On this short and narrow plateau chambers and cisterns were hollowed, loop-holes pierced in the living rock (Fig. 113). When they set about levelling out the area, upon which



FIG. 112.—Pishmish Kaleh. View of hill. Drawn by E. GUILLAUME, *Explor. Arché.*, Plate VIII.

they intended to place a garrison, the rock was cut in such a way as to leave along the outer edge a kind of wall or parapet, which, measured from the area, averages from 1 m. 25 c. to 7 and 8 m. on the south and north faces respectively. In the latter was the main entrance, if the name may be given to a gap left in the wall between two huge blocks, broken away at the base, but joining at the top (Fig. 114).¹ Towards the north-east angle rises a wall built of large units put together without cement. The rampart was thick enough to be used by soldiers on their round. Flights of steps, still in good condition on many a point, and seen in our illustration, led to the platform, whence the garrison could roll down stones and pour missiles on the enemy, whether they tried to get

¹ The view is taken from point H.

over the glacis, or force their way in through the gate from the winding path. The gateway faced north, and was covered by an outer work on a lower level, a few yards in front. It formed a round tower (1 in plan), having in its rear a sentry-box, likewise

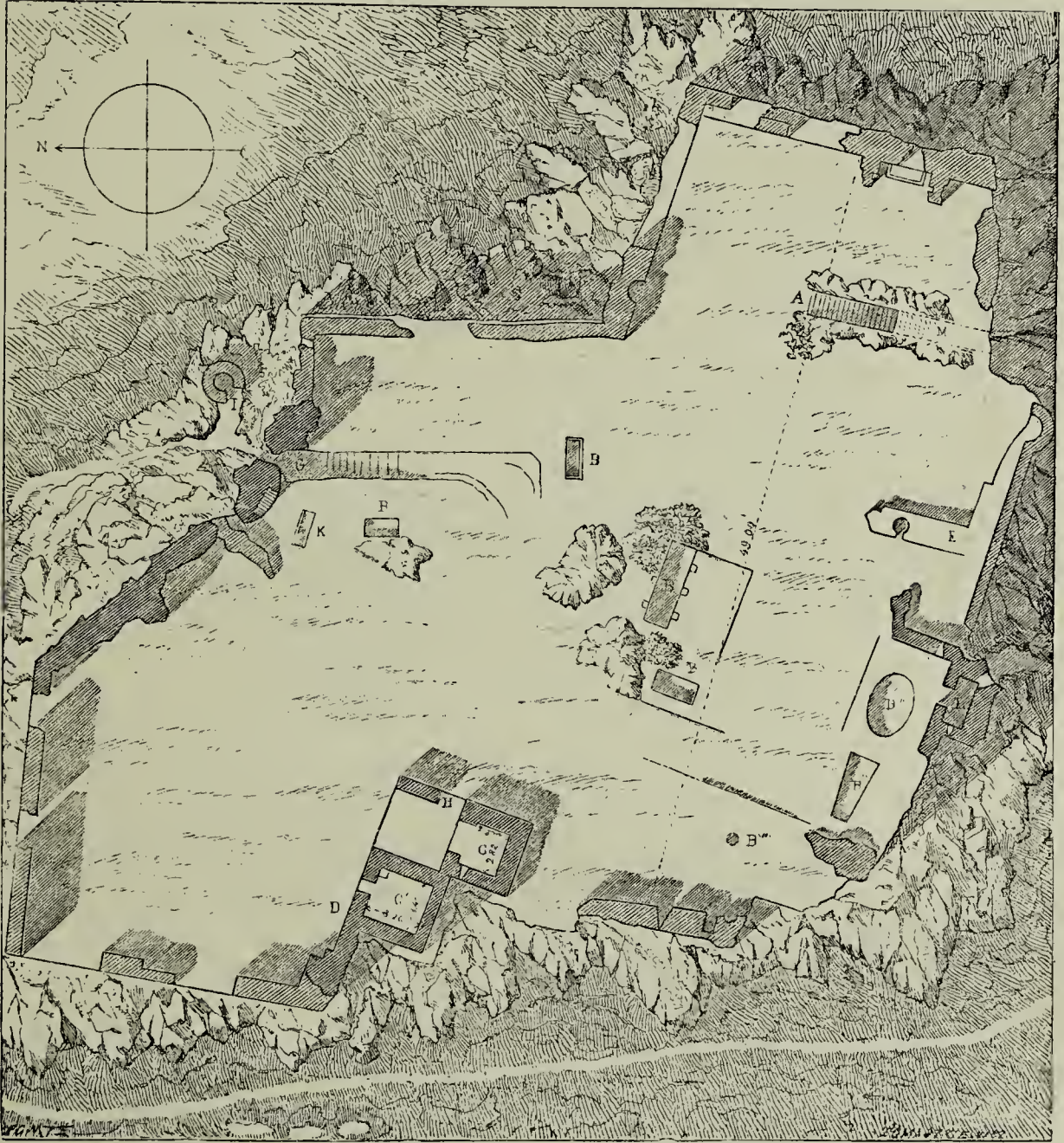

FIG. 113.—Pishmish Kaleh. Plan. *Explor. Arché.*, Plate VIII.

rock-hewn, in which soldiers on guard were posted. Built walls only occur where the rock was not thick or salient enough to allow of a rampart being reserved in the mass, as for instance at the south-east angle. Here the lower courses of the artificial wall consist of large blocks almost everywhere regularly fixed, but with irregular joints—a style of masonry which recalls that of the

Acropolis on the southern declivity of Sipylus, near Smyrna (Figs. 12, 13).

Besides the principal gateway, G, there was another entrance, or rather another means of egress, towards the north-east angle of the plateau. Here a flight of twenty-four steps, cut in the depth of the cliff, extend down to the base of rocks bearing the fortress. Two-thirds of the stairway are open to the sky; the rest is hidden under the vaulted roof and the stones which have fallen from above (A in plan). At the point where the steps break off¹ (M in plan), there appears a sort of housing, with a groove on either side, six centimetres wide; which, to judge from a small hole in the roof and the upper floor, must have served to work pulleys, by means of which a portcullis could be let down or hoisted up at will. The underground passage, which from the bottom of the stairway led outside, has the appearance of a natural cavity; its existence may have suggested the idea of scooping out the steps. It brings to mind the grotto of Aglaurus, at the foot of the Athenian Acropolis, due to a similar slit in the rock, through which the citadel could be entered.² As is well known, its discovery by a soldier of Xerxes led to its surrender.

To return: the defenders, when sorely pressed, could escape unperceived in the gloom of night by this secret passage, or suddenly fall upon the besiegers. In doing so, however, they ran the risk of the enemy taking possession of the entrance, either by force or through a traitor, and thus have their retreat cut off. Within the citadel they had only to lower the bridge to be safe against surprise.³

The stairway in the northern face (G in plan) is neither so well preserved, nor does it disappear in the bowels of the earth; its purpose was simply to bring the threshold of the gateway up to the level of the platform. On the opposite side, towards the south-east angle (L in plan), two internal spurs have been reserved in the stony mass. They are cleanly cut, each with a pair of vertical

¹ Width of stairway above, 1 m. 55 c.; width below, 1 m. 30 c.; height from the lowermost step to the fortress level, 7 m. 20 c. This leaves a mean altitude of 30 c. for each step.

² E. BEULÉ, *L'Acropole d'Athènes*, tom. i. pp. 27, 157.

³ With regard to secret passages, we may remind the reader of that which in Pterium ran under the wall, with outlet into the ditch (*Hist. of Art*, tom. iv. p. 620, Figs. 304, 308).



FIG. 114.—Pishmish Kaleh. Rock-cut rampart. Inner view. Drawn by GUILLAUME, *Explor. Arché.*, Plate VIII.

grooves down the inner face. A rectangular excavation, 10 c. deep, occurs between the two saliences, with a corresponding one in the parapet. Spurs, grooves, and artificial hollows seem to indicate that an apparatus had been prepared on this spot, either to serve as war engine or derrick, which by means of pulleys would haul up heavy loads.

It is not likely that a garrison was stationed here all the year round; the green sward of the woodlands hard by had greater attraction than the plateau, now swept by the wind, now heated like a furnace; but every measure was taken to ensure the prompt victualling of the stronghold and place it on a defensive footing. The district around is well timbered; so that nothing was easier than to run up wooden huts, akin to those which the natives build at the present day. These, however, offered but a poor shelter against wintry blasts, hence weather-proof dwellings were pierced in the solid rock. Three such chambers, 3 m. high, exist in the western face of the *enceinte* (c c), the thickness of whose walls reaches 85 centimetres. The top of the monolithic mass was levelled out, and was approached by stepped-like cuttings.

This esplanade shows numerous traces of the work of man—ditches of varying shape and size, B B' B''. Of these a few may have been graves; but others are too large to have been put to such usage. Thus, between pointed saliences which towards the centre of the platform rise above the level, there occurs a rectangular excavation 4 m. 74 c. long by 1 m. 70 c. wide, and 2 m. deep. Still visible about the ruins are holes that served to fix the slabs or beams closing the vault. This can only have been the store-room. A little beyond we find a circular hollow, B''', which looks like the mouth of a cistern or silo, now obstructed and nearly filled up. Another hollow, completely choked up with earth, appears at point κ; the deep incline of the soil seems to denote that this was the entrance to a subterranean passage, hollowed under the platform. Nor should a good-sized shelf, about 40 c. high, pierced in the east wall, E, be left unnoticed. This seems to have been a fireplace, for on one side is a rounded hole clearly intended to receive a cauldron. On the exterior wall of chamber D may be read, incised in letters nine centimetres high, the following inscription:—ΕΙC ΘΕΟC; Εἰς θεός, "There is but one God."

It is universally known that this formula—examples of which

abound in Syria, the Sinaitic peninsula, and Egypt—was much in vogue during the first centuries which witnessed the triumph of Christianity.¹ Will it be inferred that in these two words we have the signature of the nameless workman who cut, as with a knife, this citadel in the living rock? It is too late in the day to be required to give proofs that work of this kind was in the habits of the older inhabitants of the peninsula, the people who started its civilization. Later on, in certain parts of this same region, subterraneous chambers, which men of old had hollowed by thousands in the flank of the mountains, continued to be utilized as tombs, sometimes as domestic and religious abodes; such processes resulting from the inexperience of the constructor were discarded, but little was added to the legacy of the past. They knew how to build with stone and brick, with or without cement. When an elevated site was to be fortified, it was found easier to plant a wall on the rock, and raise covers behind it, than laboriously to cut rampart and subordinate defensive works in the mass of the cliff.

It was certainly not the Byzantines, in perpetual dread of fresh invasions from without, who could have attempted so laborious a mode of construction. The one thing required was the greatest amount of labour in the shortest possible time. Hence the architects of Justinian made a lavish use of mortar when they repaired or rebuilt fortresses, the long list of which is pompously set forth by Procopius. We are inclined to see here a hasty restoration, dating from the first incursions of the barbarians, when above the large blocks with which the lower portion of the walls at the north-west angle are built, there followed a chain of bricks and smaller stones ill put together. The beams in this section of the wall are in good preservation, and are enough to prove their comparatively modern date. In those troublous times, when the emperors of Constantinople fought for the possession of Asia Minor against Arab captains and Turkish emirs by turn, the citadel must have been repeatedly attacked and repaired. Barth thought to recognize, in places, the masonry of the Seljoukides.²

The inscription, at any rate, is contemporaneous with the first restoration of the fortress, which had been abandoned and suffered

¹ G. PERROT, *Explor. Arché.*, p. 145, n. 1.

² BARTH, *Reise von Trapezunt*, p. 91.

to fall into decay in those centuries of peace which marked the rule of the Roman emperors, but which was now set on a proper footing of defence. It is incised with too much care, the letters are too large to be explained as the passing whim of a casual tenant. Quite a different conjecture is suggested. Shut up in this stronghold, which he was to defend against the enemies of the empire and of his faith, the commanding officer of those days may have been a fervent Christian, who wished to affirm his creed in the face of barbarians. When he impressed on stone the holy formula, it may have been from a desire to consecrate to and place under the protection of the new god a peculiar structure due to pagan generations.

Our detailed account in respect to Pishmish Kalessi will dispense us dwelling at any length upon kindred monuments. All we know of the neighbouring heights, seemingly appropriated to the same uses, is that the rocky mass furnished the material out of which were obtained walls, ramparts, fortified posts, levelled spaces, cisterns, stores, stairways, and so forth. At the foot of the hill which bears the village of Yapuldak is a subterraneous passage, now blocked up, which led towards the plain and a stream. Travellers who have visited the site have no doubt as to its having been inhabited ;¹ they incline to think that on one of these artificial platforms there stood a princely mansion. A plan of this Acropolis and its wall of enclosure, made by M. Ramsay, will be found in *Hellenic Studies*. He likewise succeeded in taking the plan of a house at Kumbet, where the old city is covered by the modern village (Fig. 46). Works similar to these are also reported from the Ayazeen necropolis, in the rear of the Broken Tomb, where, on the plateau upheld by escarps, hypogea are seen in vast numbers.² If on the summit of several rocky masses are met vestiges of the work of man, the site where they are most marked is undoubtedly the plateau, on one side of which the Midas monument is sculptured. It brings to mind the "violet hills" of Athens, notably the Pnyx and the Museum, where the bare rock covered under clustering asphodels testifies to the laborious activity of the race whose narrow houses, closely packed together, rose in

¹ BARTH, *Reise*, etc., p. 93.

² With regard to the remains of fortifications which occur on the little Acropolis some three miles north of Ayazeen, see *Journal*, vol. ix. pp. 352, 353. For plan of the Yapuldak Acropolis, see *Journal*, vol. x. p. 180, Fig. 26.

stages on those heights.¹ The Midas level is on too small a scale to have been the site of a city properly so called; but the tribal chiefs may very well have had a temporary abode here, which they inhabited for a few weeks two or three times a year, when the ceremonies connected with these sanctuaries took place amidst the assembled multitudes gathered around them. It is not to be supposed that the place was left to itself; there always was a nucleus of stationary people—care-takers entrusted with the treasures of the chieftains, priests who watched over royal and private tombs, or sacred rocks bearing the names of ancestral deities, altars and speos in honour of Cybele.

Future explorers cannot well devote too much attention to this tiny spot, which seems to have been the official centre, the chief place of a canton where the Phrygian race has left in greater abundance than anywhere else the monuments of its cults, language, and individual culture. They should bring back with them exact tracings of all the curious dispositions the rock has preserved to this day. Such documents, if they ever come to hand, will be of inestimable value to the historian.

SCULPTURE.

We have now gone over all the monuments of any importance in this district, and the reader cannot have failed to notice the insignificant space given to sculpture. This is everywhere in flat relief; nor is there aught to be compared to the extensive figured processions which cover the rocks of Pterium.² With the exception of a ram above life size, there is not a single statue, great or small. This particular ram was discovered lying on its side, half embedded in the earth, among Turkish graves near the village of Kumbet.³ With the help of some villagers, M. M. Wilson and Ramsay succeeded in setting him "on his tail," for the nature of the ground and the thickly interspersed gravestones, says the latter, precluded his being set on his feet. It is a rectangular block of stone, 1 m. 44 c. long by 76 c. high, and 35 c. thick. Except the head, which comes out beyond the block, the relief of the general outline and the legs is indicated by a shallow groove on the side of the slab, after the manner of Pterian sculptures at Boghaz Keui and Eyuk, for

¹ RAMSAY, *Hellenic Studies*, tom. iii. p. 6.

² *Hist. of Art*, tom. iv. § vi. ch. iii. 4; ch. iv. § 2.

³ RAMSAY, *Studies*, pp. 25, 26.

example, where we studied the curious mingling of parts in low relief opposed to others worked in the round.¹ The head is much

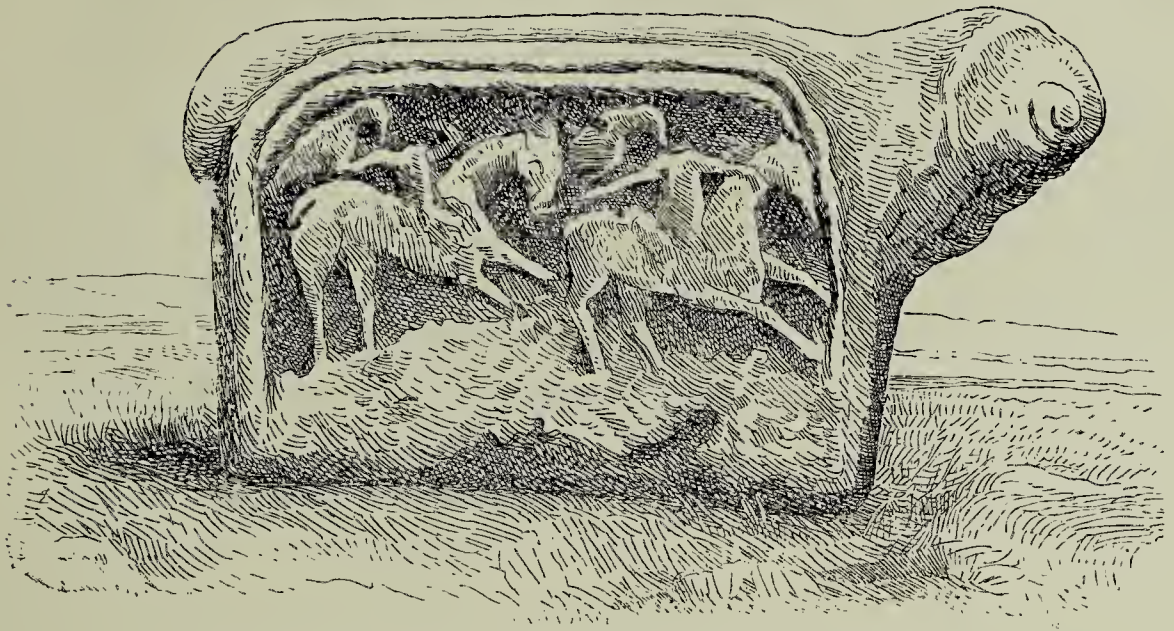

FIG. 115.—Stone ram. Left side. *Journal*, 1882, Plate XX.

injured; the horns and the tail—the flat broad tail of the sheep of the country—are the only distinct features that serve to identify

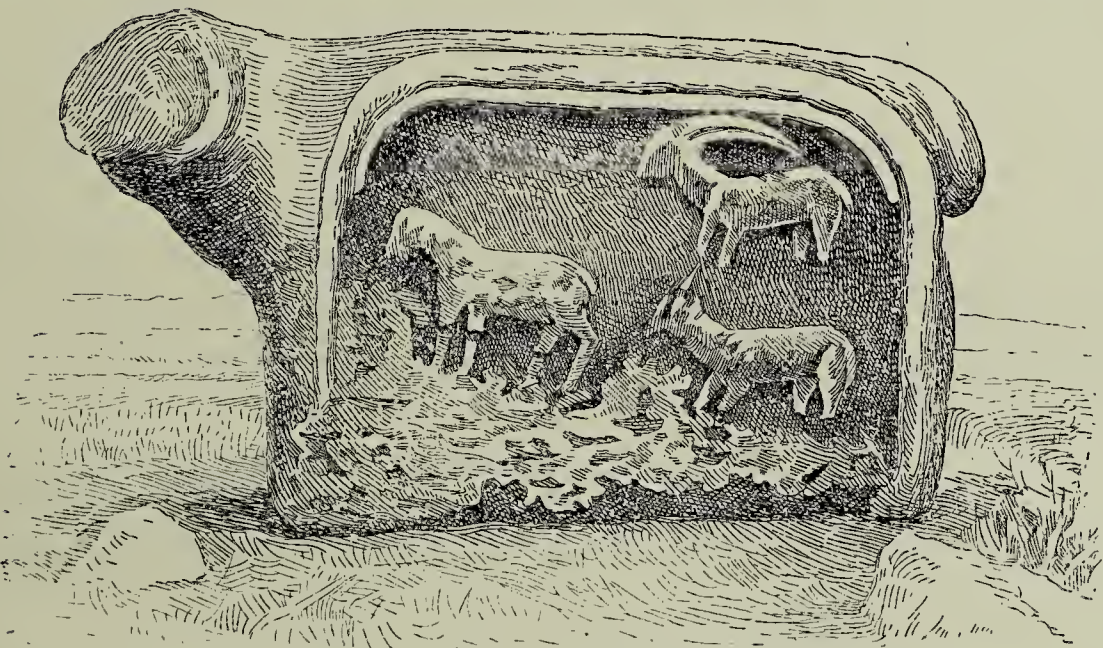

FIG. 116.—Ram carved on stone. Right side. RAMSAY, *Journal*, 1882.

the kind of animal to which they belonged. Thus, we find here the same conventionalism, the same compromise, the same want of power in setting free the living figure from the mass of stone where it lies imprisoned, which characterize Cappadocian art (Figs. 115, 116).

¹ *Hist. of Art*, tom. iv. pp. 548, 611, 581.

A curious thing about this image is that the artisan grafted on it a second which has no relation to the first; thus he put a bas-relief, bounded by a double strip, on each face of the stone. On the one flank are three objects with long horns apparently belonging to wild goats, and on the other flank two horsemen, and above them two birds on the wing. A hunting scene was clearly intended here. The manipulation is inexpressibly barbarous; but the situation of the birds is precisely similar to that of numerous instances seen in the bas-reliefs of Assyria and the metal bowls of Phœnicia.¹ It would be difficult to imagine aught more strange than these data, workmanship ruder or clumsier, particularly the horses and their riders.

As to the function of the ram, it is easily guessed. He had a pendant, and the pair decorated the threshold; they were regardant, *e.g.* with heads turned away, and played the part of the huge winged bulls of Assyria, the lions of Comagena (of which several were found in place), and the sphinxes and lions at Eyuk.² Thus may be explained the awkward overcrowding, which sins against the canons of good taste. The primitive artist, in his endeavour to enhance the importance and power of his patron, bethought him of no better contrivance than to figure him at his favourite pastime, the pursuit and capture of big game. Both at Nineveh and in Upper Syria, in that Hittite palace, of which the ruins are seen at Sinjerli, the basalt and alabaster casing of the lower part of the walls is covered with scenes descriptive of the main episodes of royal existence.³ In this instance, the house of the tribal chief was, perhaps, no more than a wooden konak, like that of the Dere Bey at Kumbet (Fig. 83). Two huge stone blocks set up at the gateway were all the Phrygian artist had to hand; and in his anxiety to do the best he could with them, finding, moreover, no other available space, he carved the hunting scene on the flanks of the ram.⁴

¹ *Hist. of Art*, tom. iii. pp. 767, 793.

² *Ibid.*, tom. iv. pp. 533, 534, Fig. 269.

³ *Ibid.*, pp. 530, 535, 559, 680.

⁴ Milchhöfer sees in this ram a funereal symbol, which he compares with those seen in the bas-reliefs of Caucasus and the tombs of Armenia (*Wilderdenkmäler aus Phrygien und Armenien, Archæ. Zeitung*, 1883, p. 263); but Armenian presentations of the animal, such as these, are after the Christian era, one bearing the date of A.D. 1578. To try to establish a link between monuments separated by so wide a space in time seems very risky. Our explanation has this in its favour, that it does

The Phrygian sculptor then, even in works apparently of remotest date, now and again tried his hand at reproducing the human form. Of this we have proof in the image which stands near a sanctuary of the Midas plateau (Fig. 101). This image is decidedly in advance of the two horsemen we have just described, yet it betrays so unskilful a hand as to have no style, it being mere child work. As to the figures sculptured along the roadside which leads to the plateau,² there are data about them which raise the question as to whether they do not belong to a very late period—the first or second century of our era, when the monuments, in far better condition than they are now, were visited as a curiosity. At that time the inhabitants of this region were fully conscious of the glorified interest attaching to these Phrygian myths. The poetry and art of Greece had done much towards their development; nevertheless, here in their primitive home they preserved much of their primary character, nor was their hold upon the native populations much less than of old. That the latter were justly proud of the traditions relating to their past is shown by the coins of this period, which bear on one side the name and effigy of Midas (see tail-piece, end of chapter).

It is quite possible, then, that some local worthy, in the day of Augustus or the Antonines, had these pictures carved on the rocky wall as a reminiscence of the chief episodes which the old legends current in the district had to tell. Does not M. Ramsay identify one figure with Marsyas, hung up to be flayed?¹ If the modelling of the image is mediocre in the extreme, the arrangement of the theme belongs to Greek statuary. Now, as proved by the whole array of Syro-Cappadocian sculptures, the archaic art of the peninsula had nothing to say to undressed models, and never figured them but amply draped. Finally, we are told that “the two pictures heading the procession are exceedingly thin in proportion to their height.” And slender proportions are neither in the habits of Asiatic sculpture, nor, in a general way, in those of archaic art, which prefers thick-set dumpy forms. M. Ramsay

not outstrip the domain of archaic art, and is referable to a disposition which exemplars furnished by Babylon and Nineveh brought into repute throughout Anterior Asia.

¹ RAMSAY, *Studies*, Figs. 1, 2.

² *Ibid.*, p. 6.

goes on to say that the distinguishing feature in some of these figures "is a certain ease and grace in their outline, especially in the line of the back."¹ All these details put together, as well as variety of pose, would appear to preclude the notion of remote antiquity. We should be inclined to think that the one picture really old is that near the altar (Fig. 101); all the rest would be Græco-Roman sculpture, but due to provincial or, if preferred, rural art. The habit of carving bas-reliefs in the flank of rocks persisted very late in Asia Minor, as in Syria and Persia. Any one interested in the subject will find numerous specimens by turning over the leaves of our *Exploration Archéologique*, Plate

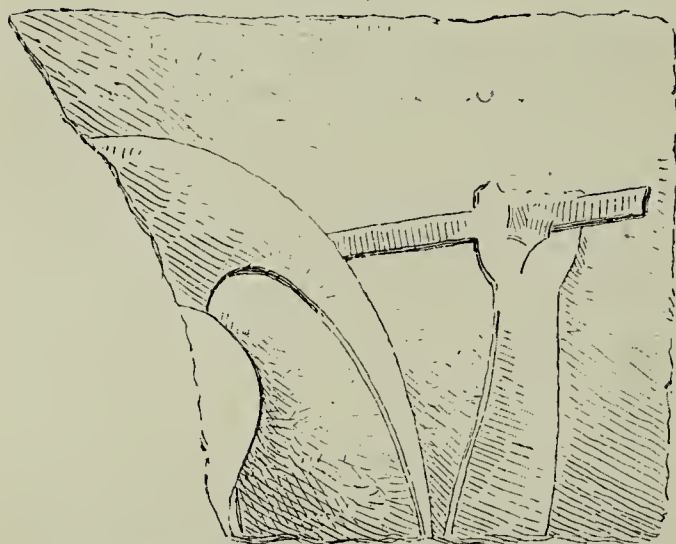

FIG. 118.—Bas-relief of Broken Tomb. Drawn by St. Elme Gautier after Ramsay.

XII., as well as in works of our predecessors, T  xier, Le Bas, Stewart, and others who have worked in the same field.

On the other hand, we must recognize as a production of indigenous, of true Phrygian art, the sculpture which decorates the northern front of the hypogee we have called the Broken Tomb (Fig. 65). It represents two warriors, one on each side of the slab, in conflict with a monster (Figs. 117, 118). Each carries a heavy-circular shield on the left arm; the other is raised, and holds a spear which runs into the head of the enemy. Our knowledge of Phrygian mythology is too scant to

¹ RAMSAY, *Studies*, p. 7. M. Ramsay does not share our doubts as to the great age of the processional figures (*Journal*, x. p. 167). The question is not one to be solved away from the monuments or photographs of the same, as in my case. Hard by the figures under consideration is one with two characters in front that would appear to be Hittite. This figure, apparently very different from the others, I engraved in *History of Art*, tom. iv. Fig. 355, from a sketch placed at my disposal by M. Ramsay; to-day he produces another drawing, which he declares is more correct than the first, and is intended to show the great similarity of profile common to all these figures (*Mittheilungen Athens*, xiv. Fig. 4). Granting the absolute accuracy of his last image, when placed side by side with Fig. 5, it will, perhaps, be found that his hypothesis is weaker than our own. At all events, the worn state of these monuments makes it very difficult to assert one way or another with any degree of confidence.

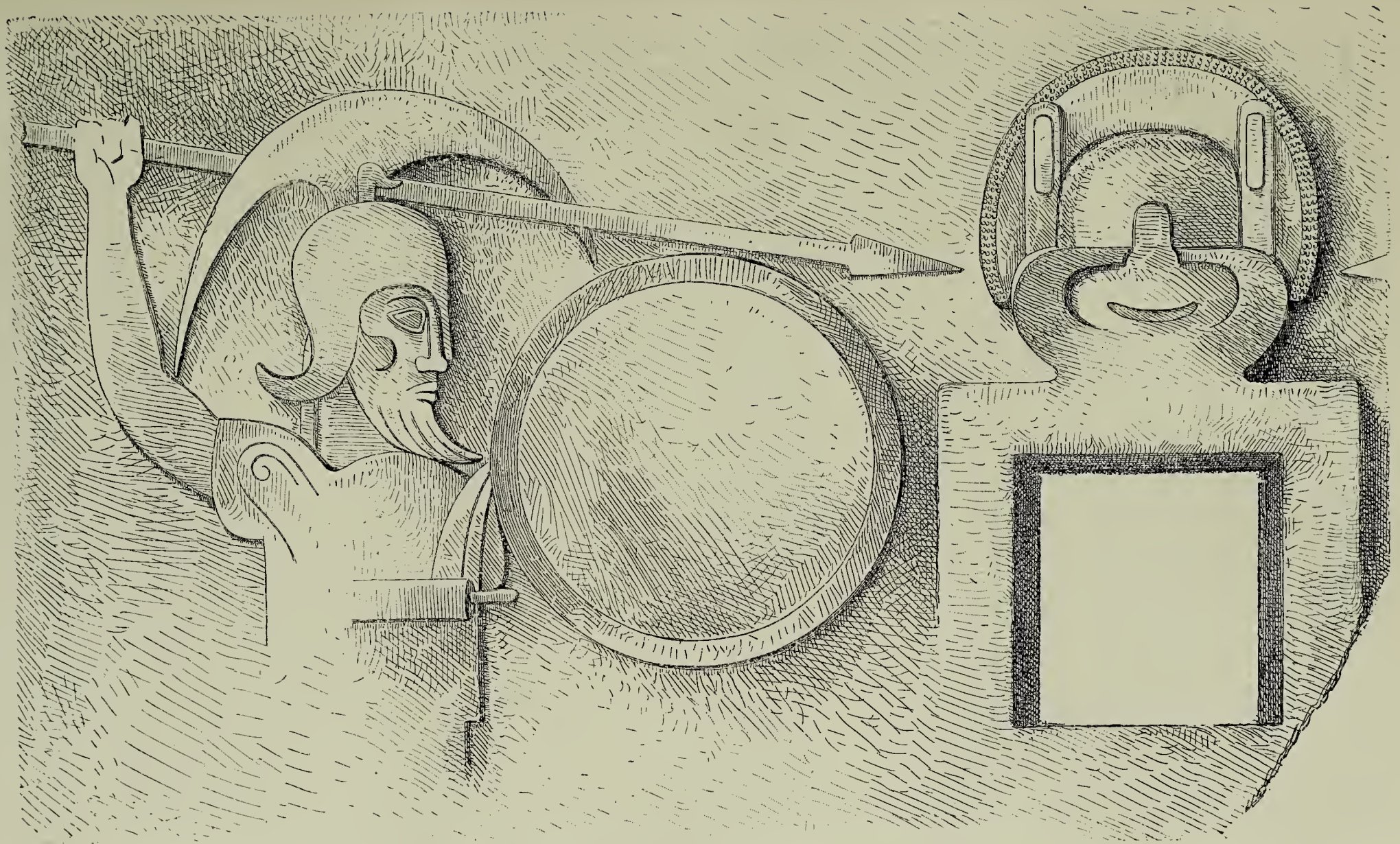

FIG. 117.—Bas-relief of Broken Tomb. Drawn by St. Elme Gautier after Ramsay.

enable us to give a name to the twin knights, but the meaning of the symbol they embody is easily grasped. The part the warriors enact is analogous to that which the gods and heroes of Assyria and Persia are made to play, whether on cylinders or sculptures adorning the portals of Chaldæan palaces, where they are seen strangling a lion, or plunging their sword in the griffin's throat. Here their function is sharply defined by the situation they occupy, which is that of protecting genii of the grave; they guard the dead against the demon. Of the monster, nothing remains but an immense head, drawn full face; the outline, it would seem, of the Medusa of Greek statuary. That the rudimentary, rough style of the image was intentional—the eyes are not even indicated—is proved by the surrounding parts of the sculpture, which declare a far more advanced stage of art.

The horseman on the dexter hand of the doorway¹ alone remains in position (Fig. 117).² The other half of the stone is broken, save the chip bearing the arm which holds the spear, and which we reproduce from the joint efforts of MM. Ramsay and Blunt in Fig. 118. Despite the smallness of the size of the fragment, a certain restoration is rendered possible by the position of the spear, the end of which protrudes beyond the bay.³ The perfect resemblance of limb and feature between the two actors in the scene extended to their attitude, which was the exact counterpart one of the other. The bare arm is well drawn, the movement natural and satisfactory; it stretches out well. The lower part of the figures is wanting; one was cut across the chest by the fall of the stone which formed the north-west corner, and the other is banked up to a little above the knee. The lower edge of our illustration breaks off somewhat above this place, the reason of which will be found in footnote. Hence we cannot say whether the legs were encased in gaiters; but the other items of his armour are those which the epos and ancient Greek pottery

¹ The position of the remaining horseman has been corrected from the errata.—
TRS.

² M. Ramsay admits that our illustration (Fig. 117) gives a better idea of the relief than his engraving (Fig. 9, *Journal*, ix. p. 363). He observes that the ringlets of the Gorgon are *on the side*, and *not* on the edge of the relief, for the simple reason that details so disposed would not be seen in a figure drawn full face.

³ M. Ramsay, during his visit in 1881, took a sketch and measurement of the fragment, from which the skilful pencil of M. Blunt produced the original of Fig. 118. It should be observed that the worn part of the stone is left out.

ascribe to the heroes of Homer. These consist of a breast-plate, or thorax; a circular shield; a sword stuck in the belt, with short slender hilt protruding from a large sheath; a heavily crested helmet with neck, nose, and cheek pieces, which latter could be raised or lowered at will.¹ The crest was a very striking item, formed of two parts: a bird's head and a ridge or narrow band of metal, crescent-shaped, the *φαλος* of the poets. I know of no Hellenic monument better calculated than this to help one to grasp the meaning of the lines describing the phalanx led by Patroclus against the Trojan Sarpedon: "Men against men,

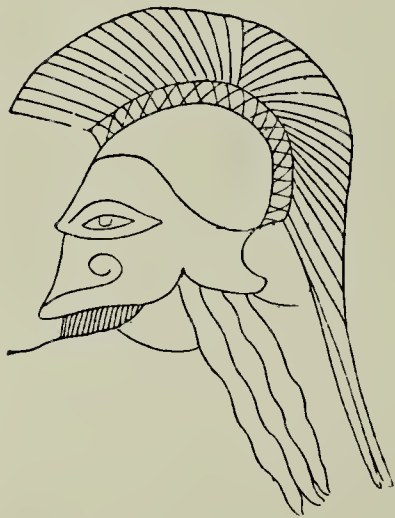

FIG. 119.—Helmet, from Greek vase with black figures. HELBIG, *Das Homerische Epos*, p. 298.

shield against shield, helmet against helmet, with shining crest, over which waved wisps of hair. The men in the second row, as they lowered their heads, touched the helmets *falling on the shoulders* of the men in front, so close against one another were the combatants."² The crest depicted here has a deeper projection on the brow and on the nape of the neck than is to be found on Greek vases, on which the figures are black (Fig. 119). Then, too, in paintings the topmost part is fixed throughout to the metal ridge, whereas here the only mode of attachment between crest and helmet-cap is a

hook-like projection, which cannot have offered the same solidity (Fig. 117).

There are points in the treatment of the face which should not pass unnoticed. Thus, no doubt to save trouble, the eyeball is not indicated; nose and lips approach the negro type.³ There is no moustache; the upper lip is shaved, but a small pointed

¹ HELBIG, *Das Homerische Epos*, etc., 1887, pp. 298–300.

With regard to "Homeric armour," consult Leaf, *Hell. Studies*, iv. pp. 281–304; Dennis, iv. pp. 11, 12.—TRS.

² *Iliad*, xvi. pp. 215–218.

The above lines would appear to be a paraphrase, inasmuch as they contain more than I could find in the text.—TRS.

³ If these characteristics are non-apparent in the illustration, writes M. Ramsay (*Journal*, ix. p. 366), that is because neither his travelling companion nor himself was able to reproduce faithfully what he saw. He straightened the nose, thinned the lips, and refined the contour beyond reality.

beard falls below the chin. This mode of dressing the beard was in vogue among the nations of Syria and Asia Minor from the eighteenth Egyptian dynasty; whence it passed to Greece, where it persisted down to the classic age.¹ Long-pointed beards, akin to those of our sculpture, appear in the golden masks of Mycenæ.¹

The surface upon which the figures are carved is 5 m. 78 c. long by 2 m. 20 c. high. If we suppose the pictures when complete to have been whole figures, they would average from 2 m. 40 c. to 2 m. 50 c.; that is to say, far above life size. Despite conventional treatment and too precise a symmetry, effect and nobility were assured to the sculpture by sheer size, truth, and breadth of movement. It conveys in full the idea it was intended to express. There is a felicitous contrast between the huge grimacing head of the Gorgon and the proud bearing of the two victors. The former is a whole head taller than her adversaries; the legs are bent at the knee and wide apart, so as to allow the feet of the three actors to rest on the same plane: an arrangement which leads one to imagine a pose for these figures akin to that exhibited in archaic Greek sculpture, to express the idea of swift running.

The bas-relief under notice, unknown but yesterday, occupies a place quite by itself in the art productions of Phrygia. In effect, when the native artist wished to endow his great goddess Cybele with a body, all he was able to do was a gigantic puppet, in which no attempt was made to indicate the features of the face, the nature and arrangement of fold in the drapery. We feel that when occasion offered to attack the human form, he was utterly unable to grapple with it. Thus, in one of the sanctuaries of the plateau, where the latter would seem to have its place marked out, did not he shirk the difficulty and replace the divine simulacrum by an emblem suggesting it (Fig. 106)? On the other hand, in common with all primitive artists, he is far more at home in his presentation of animal forms; and in this domain he gives proof of genuine talent and natural gifts. Thus, in the group in which Cybele is represented between two lionesses (Fig. 110), whilst the effigy of the goddess is no more than a kind of head-stone or pillar, the general outline of the animals is drawn with precision, and the movement is exactly what it should be. The same impression is felt in presence of the colossal lion,

¹ HELBIG, *Das Homerische Epos*, 2nd edit., pp. 247-256.

who has given the name of Arslan Kaia to a monument met with in the neighbourhood of Liyen (Fig. 108). Neither modelling

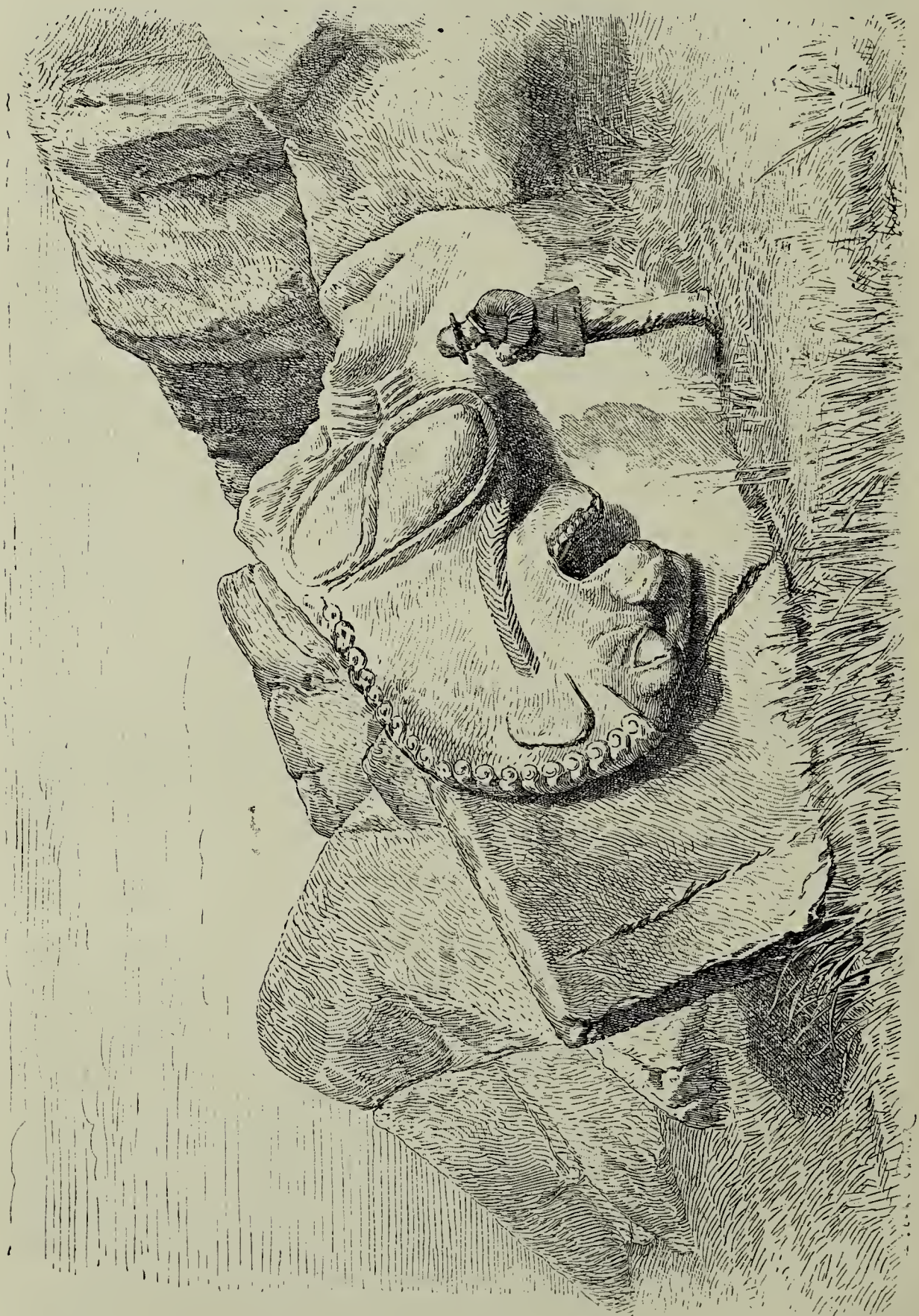

FIG. 120.—Lion of Broken Tomb. Drawn by St. Flme Gautier from a photograph.

nor details were indicated within the image; but the contour has enough of frankness to enable one to appreciate the justness of

feeling which regulated the proportions of this huge sketch, which the sculptor, with rare boldness, flung high up on the rocky wall.¹ In point of interest, perhaps no manifestation of the plastic art of Phrygia can compete with the lion (Fig. 120), now reduced to a mere fragment, and which belongs to the tomb on whose exterior the two warriors are carved (Fig. 65).

Measured from the nose to the back of the neck, this lion was 2 m. 30 c.; that is to say, far beyond the Arslan Kaia exemplar, whose relief it also surpassed. The latter, about 15 c., was obtained by cutting round the outline parallel lines at right angles to the ground of the stone. High relief, however, was not used by the artist for modelling the flesh, the planes of the shoulder being alone marked; the latter is more salient than the neck, to which it is not allied by a curve as in nature, but by clean cutting at the edge. The other details—hair and folds of skin on the forehead, muscles of the shoulders—are marked by sharp, rigid strokes, which recall the processes of engraving rather than those of sculpture. The mane, which contributes so much to invest the lion with his peculiar physiognomy, was well brought out by the artist in a series of tightly curled ringlets, carved in the plane of the bas-relief, very similar to those that surround the faces of archaic Greek statues. The work is continued in a different form on the vertical edge surrounding the slab. Here tufts of hair are indicated by oblique parallel lines incised on the slight ridge. But this very rudimentary mode was not confined to a portion of the work, where it must almost have been lost to view; the same herring-bone pattern is found on the more apparent sections of the sculpture, from the ear along the cheek, where it perhaps marks the mane fringe, thence under the chin, the breast, the shoulder, where it corresponds to the wrinkle seen above the joint, the back of the quadruped, and finally on the fragment bearing the two paws, which, we think, belong to other two lions (Fig. 122). The slab was broken off just at the point where the fore-parts are joined on to the body; but the head, the most carefully wrought portion of the animal, remains.

Exception must be made for the ear, which is nothing but a triangular surface with a deep salience on the plane of the face.

¹ Our illustration is from a sketch taken from below and too near the object. The result has been, M. Ramsay informs us, somewhat to alter the proportions of the lion, and make him look more lank than he is in reality.

It is small in comparison with the size of the head, as a lion's ear should be. The eye is deeply cut, and the eyelid frankly projects, with a clean vertical edge, from the eyeball. The muscles about the cheek, the wrinkles of the nose, are rendered with truth and decision as if from direct observation of the living animal; other details, however, would seem to belie such a conclusion. If there are no teeth in the upper jaw, that is because they were broken when the block fell in, but the marks left by them are still distinct. Those in the lower jaw are well preserved, and curious to behold in a lion's mouth. Instead of the nail-shaped, sharply pointed teeth proper to animals of prey, it is the broad, flat molars of herbivorous animals which make their appearance here. Yet it seems probable that when these sculptures were executed the lion still haunted the hilly range of the peninsula; he fills too important a place in the Homeric poems, his habits and physiognomy are painted in too lifelike, vivid colours, to induce the belief that the dwellers of the Ægean coast only knew him from the accounts of travellers and the more or less conventionalized portraiture of Oriental art.

Despite these inexactitudes and the very arbitrary mode in which certain details are handled by the artist, the figure had its modicum of beauty and dignified aspect. What was its attitude? In all likelihood the lion was rampant, as in several monuments of this neighbourhood (Figs. 64, 79, 92). Our illustration (Fig. 121) shows how M. Ramsay thinks the animal can be restored. Of the other two lions carved, he thinks, on the same face of the tomb (F in plan, Fig. 66) nothing is left but two paws, opposed one to the other—a movement suggestive of two animals set up against each other in true Oriental taste and fashion (Fig. 122).¹

The decoration of the broken tomb is perhaps the masterpiece of Phrygian sculpture. Next comes the exemplar with two lions standing on their hind legs, and separated by a pillar. The work, though in better condition, betrays a more rudimentary style, and the relief of the two great figures is not so accentuated; in both, however, the joints, muscles, and folds of skin are indicated by the same process. The main front faces north, and is for the most part covered with greenish moss. As the figures are considerably above the ground, details are not easily made out, but the eyes,

¹ The two restitutions (Figs. 121, 122) are made from sketches by M. Ramsay; the parts restored are merely outlined.

ears, wide-gaping mouth, protruding tongue, and the teeth in the lower jaw are easily discernible. The sculptor made the head and shoulders larger than life. The exaggeration was perhaps intentional so as to add to the effect, and intensify the appearance of strength and power of the two colossal animals. The pose is very frank and the meaning of the group easily grasped. Despite

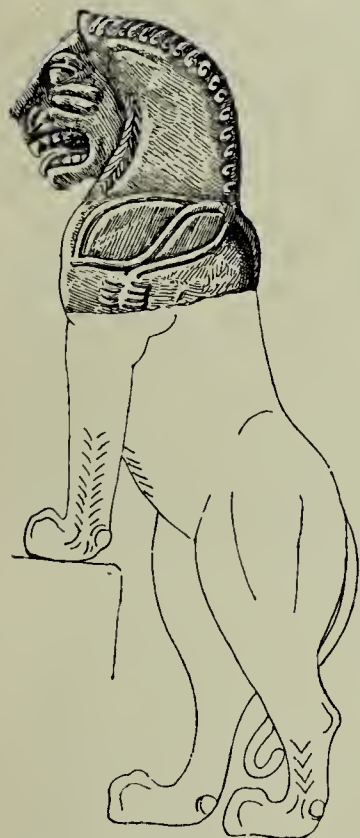

FIG. 121.—Broken Tomb.
Restoration of rampant lion.

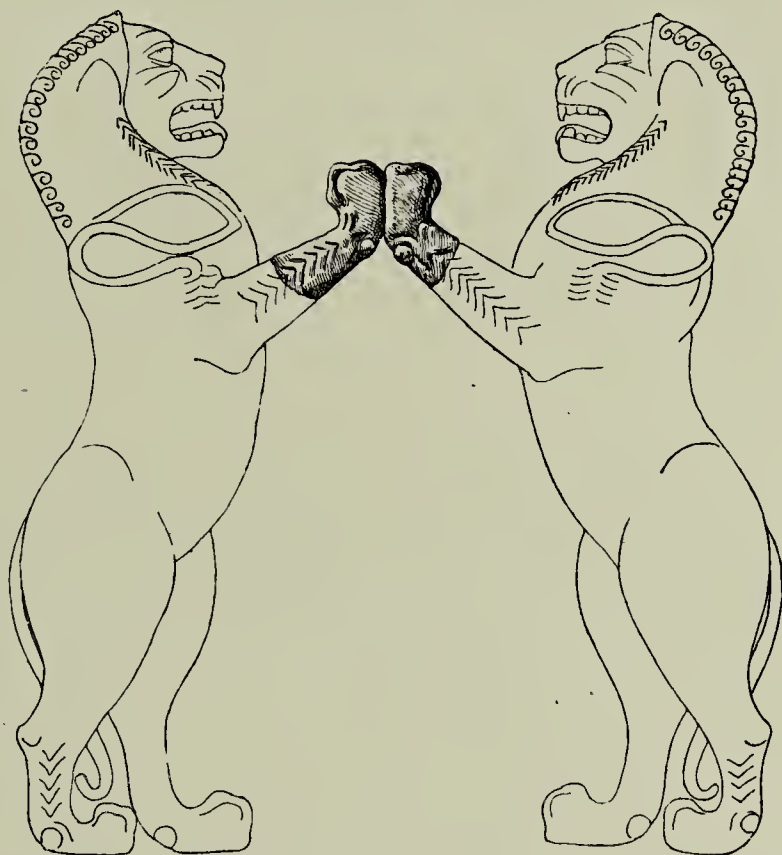

FIG. 122.—Broken Tomb. Restoration of the two lions face to face.

the rudimentary character of the execution, the two figures, boldly flung athwart the living rock, have a fine air enough.

However simple, then, Phrygian art is not without merits. That in which it is most deficient is variety. At no stage of its development does it seem to have known how to model in the round boss; it never rose above flat relief, and even then the process is only applied to a very limited number of themes. It is possible, however, that some of the types it created or borrowed have not come down to us; many a picture chiselled in the rock may have been destroyed by the fall of the tufaceous mass, one of whose faces it ornamented. Excavations, such as would be likely to bring to light bronzes and terra-cottas, have not been attempted hitherto in Phrygia; yet there is no reason to suppose that the Phrygians were ignorant of the method of casting in bronze or

fashioning clay. The ancients mention a female statue of bronze, which would seem to have been put over the tomb of one of the Midases; probably the king who married the Greek Demodike of Cymæ.¹ A line of one of the Rhapsodists, referring to the figure, is extant, and in the true spirit of the age the statue is made to speak—

“I am a bronze maiden, on Midas' tomb I lie.”²

Where was the tomb? We are not told, and do not propose recognizing it in the monument we have described, albeit we can imagine a bronze statue to have stood on the ridge of the rock, over the double volute crowning the pedestal (Fig. 48). At all events, it is difficult to admit that the line in question is a pure invention; the meaning of the epigram would be pointless, unless we suppose it to have been applied to a well-known work. Even supposing the object in question to have been executed in Ionia for a foreign prince who was popular and well thought of there, the fact remains that it had to be despatched to Phrygia, where it served as model and diffused at the same time a taste and practice in the art of working metals.

Up to the present hour, Phrygia has yielded no intaglios or small figures, whether in clay or bronze. Nevertheless, those princes who knew how to write, who sent objects of art as presents to Delphi, could not but have signets of their own; this is rendered the more probable that the usage of the seal was firmly established among the neighbouring nations. Of late, the attention of archæologists has been called to cylinders and cones whose *provenance* and peculiar make stamp them as the work of a local art proper to Asia Minor.³ But what is still undiscovered are seals wherein the image would be associated with alphabetical characters, akin to those manifested on the inscriptions of the Nacoleia district. When intaglios shall appear with real Phrygian lettering, such as we see on the Midas monument, a new and curious chapter on glyptic art will have to be opened.

¹ Diogenes Laertius, i. 89; PSEUDO-HERODOTUS, *Life of Homer*, ii.; C. F. BERGK, *Geschichte Griechische Litteratur*, tom. i. p. 779.

² Χαλκῆ παρθένος εἰμι Μιδέω δ' ἐπὶ σήματι κείμαι. The verse was ascribed now to Cleobulus, one of the seven wise men, now to Homer.

³ *Hist. of Art*, tom. iv. pp. 665-774; HEUZÉY, *De quelques cylindres et cachets de l'Asie Mineure* (*Gazette Arché.*, 1887, pp. 55-63).

ORNAMENT AND INDUSTRIAL ARTS.

A country where, as in Phrygia, sculpture has had but a mediocre development is not likely to yield rich and varied stores in architectural ornament. Of its artistic productions only the merest wrecks have been preserved, so that the study of decorative composition is confined to sepulchral façades. The framework and inner shapes of these are borrowed—the first from timber constructions; the latter, by a long way the most advanced in style, from patterns worked in the loom or with the needle.

The number of stone buildings would seem to be very small in the valley of the Sangarius. This is to be accounted for by the soft loose texture of the rock, a poor material to work upon at best, and the abundance of timber. As soon as the subterraneous abode ceased to satisfy the growing needs of the population, when something more spacious, airy, light, and gay was required, oaks and pines furnished the elements out of which the house was made. The result of this is that here stone has not the forms belonging to it, as in Egypt for example, whether in the façades or the doorways of mastabas, the sarcophagi and stelas of the older empire,¹ where the shapes are unmistakable imitations of carpentry work. It is a wholesale imitation, flagrant and servile; not only traceable in the leading lines, but in the minutest details as well. The Phrygian façade, without one exception, may be described as a rectangular space, comprised within a frankly accentuated frame, surmounted by a triangular pediment (Figs. 58, 59), in which all the essential parts of the front of a wooden house are reproduced. Thus, the false pilasters bounding the frontispiece right and left are copies of wooden posts, found at the angles of the square as main-stays to the building. The plain band upheld by the pilasters is the tie-beam of unsquared timber, deeply mortised at the sides to let in the pilasters and keep them in position. The elongated triangle crowning the frontispiece is the gable and framing which support the roof, of which every detail of the timber structure is literally rendered in the stone-work; back-rafters and trusses meeting in the centre, where they form a double volute. The latter could easily be obtained from wood, either in the main end of the beam, when a deep salience of contour and corresponding channel were

¹ *Hist. of Art*, tom. i. pp. 508-516.

desired, or carved almost flat on applied pieces. In countries, as Switzerland, where timber architecture has never been out of fashion, the top of many a gable will be found ornamented by the volute device.

The subordination of stone to lignite types, and the effort to

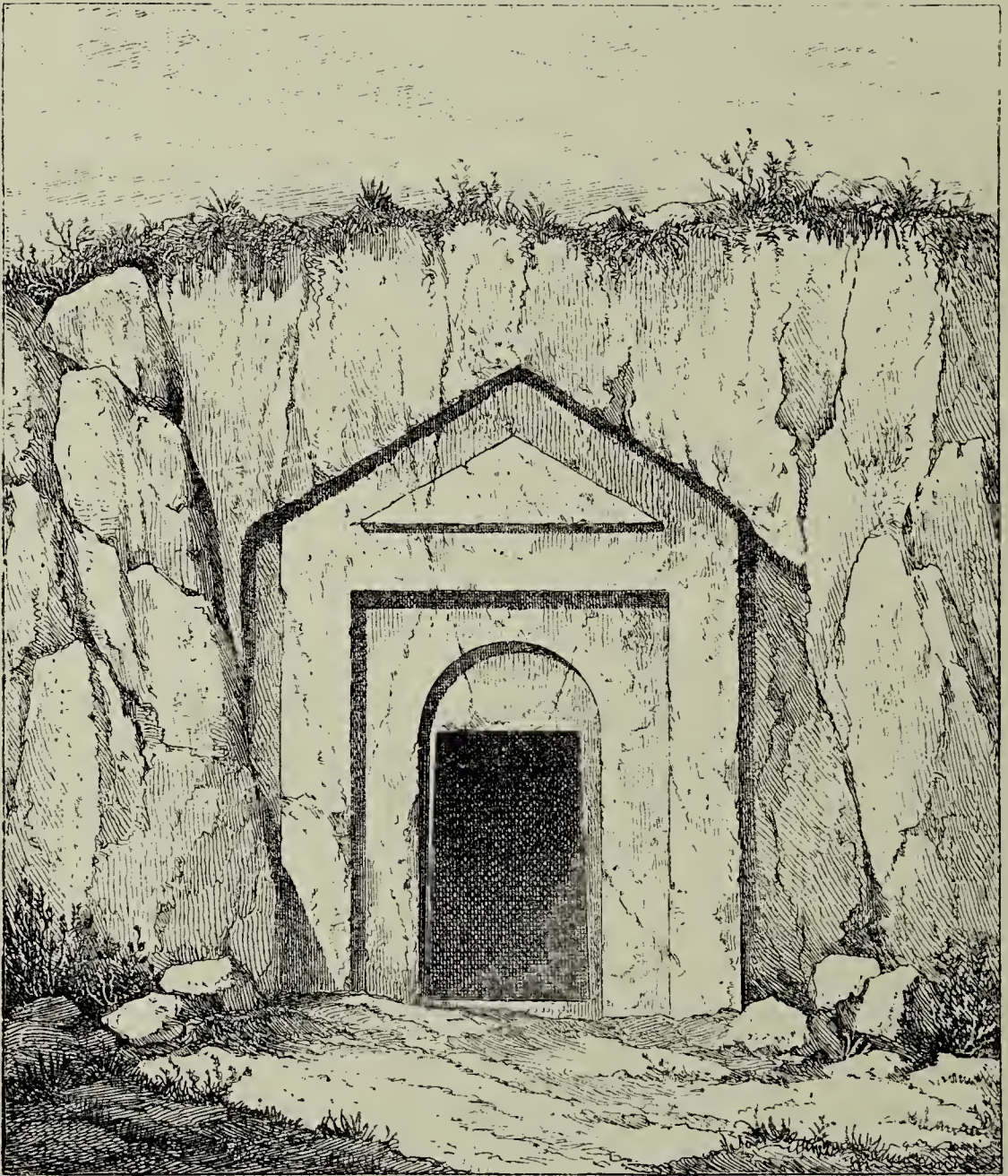

FIG. 123.—Tomb near Iasili Kaïa. Elevation. T  xier, Plate LVII.

imitate them, are not confined to the exterior of these fa  ades. We find them also as projecting beams of a flat ceiling in a chambered grave of this necropolis; and, again, in the first apartment of a tomb westward of Iasili Kaïa, whose ceiling reproduces the disposition of a pointed roof, along with its purlins, cross-beams, and covering. The tomb was noticed by T  xier, of whom we

borrow elevation (Fig. 123), plan (Fig. 124), and section (Fig. 125).¹ His tracing, however, shows no sign of the detail in question, which we were the first to point out, of which a fair idea may be gained from M. Guillaume's sketch (Fig. 126).²

Imitation of wooden forms extends from the exterior to the interior of the building, where it may be traced in pieces of furniture. Thus, within the tomb figured above were funereal beds for the bodies, cut in the solid rock (Fig. 125).³ They are much too plain to be considered, like those

M. Heuzey brought out from the depths of a tumulus at Pidna, as copies of costly furniture, luxurious couches, metal-plated, upon which the wealthy reclined at banquets. These are modelled on the ordinary instances to be found in every house, of which the hypogea are faithful representations.

Among other ornamental details to be mentioned as imitated from timber structures, are those raised roundels about the pediment, which bring to mind the salient knobs seen on the door-valve (Fig. 58). It would even seem that a door-handle was

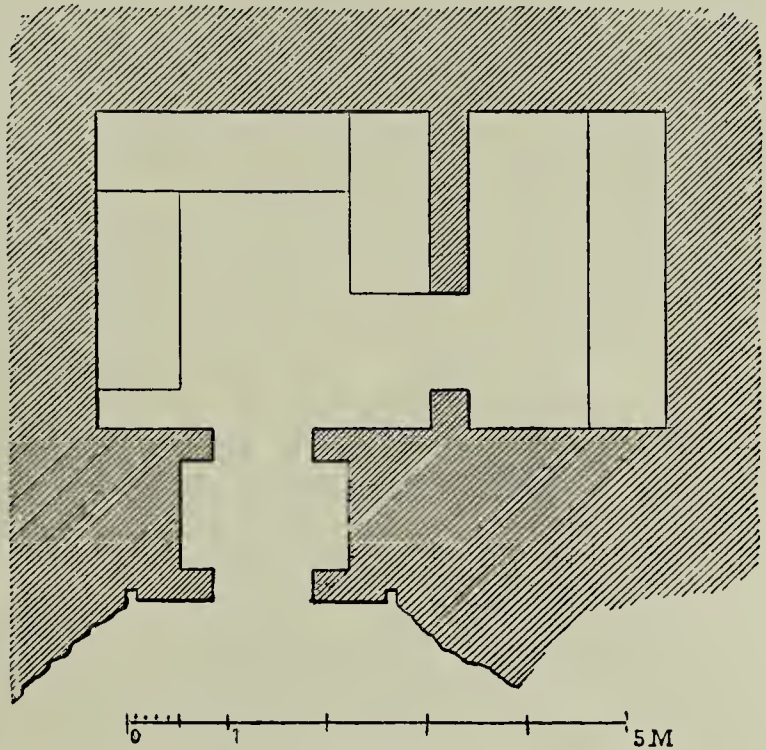

FIG. 124.—Tomb near Iasili Kaia. Plan. Tèxier, Plate LVII.

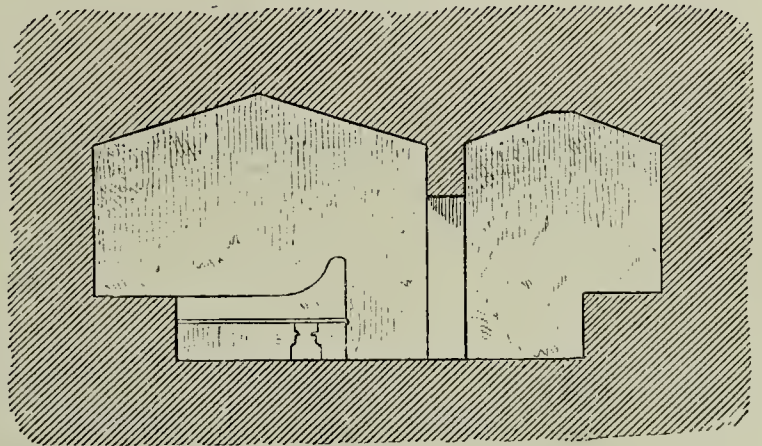

FIG. 125.—Tomb near Iasili Kaia. Transverse section. Tèxier, Plate LVII.

¹ TÈXIER, *Description*, tom. i. p. 156.

² PERROT and GUILLAUME, *Explor. Arché.*, tom. i. pp. 146, 147.

³ HEUZÉY and DAUMET, *Mission archéo. de Macédoine*, Plates XX., XXI.

identified in the middle of the panel, whilst the lozenges carved about a number of these frontals are supposed to be reminiscences of joists (Figs. 48, 58, 59). When similar squares appear under the side beams of the pediment, as in the Midas rock, such a value may be given to them ; as to those in the inner slab, however, set out in sets of five, so as to form crosses, it is more natural, perhaps, to consider them as belonging to the category of designs imitated from carpets or embroidered stuffs. Lozenges, squares, crosses, meanders, all the forms that ornament these sculptured fronts, are of the kind the looms and the broderies of Asia Minor easily produce at the present day ; be it on those justly prized carpets made in the province which answers to the Lydia and Phrygia of olden times, or the bodices and aprons the native women embroider for themselves, even to the rosettes seen now and again on these frontispieces (Fig. 59).¹

The way to read these rock-cut monumental fronts is this. The tomb here, as elsewhere, is but a copy of the house. But the house which had served as model was wholly enclosed in masses of timber, pinned to supporting beams at the angles, which yielded no space to speak of whereon to trace furniture or ornament so as to introduce variety into the scene. Consequently the ornamentist was compelled to seek in other fields forms which it was not in the nature of a lignite architecture to furnish. These he found in profusion in the sumptuous webs, for which the country has been noted from the earliest age ; where they served as floor and wall covering, drapery to divans—of which an instance is found in these tombs

¹ Stewart was the first to notice the striking analogy which exists between sepulchral and textile ornament (*Description*, p. 9) ; whilst M. Ramsay (*Studies*, iii. p. 27) lays particular stress on the resemblance these sculptured fronts bear to hanging carpets.

This theory, which he strenuously advocated in 1882, he now abandons in favour of terra-cotta and metal inlays ; and he holds that the style of ornamentation which appears on these fronts "is but the imitation in stone of some kind of tile-work, *e.g.* the covering of a flat surface, floor, wall, and so forth, with a pattern of tiles or of square plaques of bronze" (*Journal*, x. p. 153). To this view we will oppose the following remarks :—It is not easy to conceive how wooden structures, the forerunners of the rock-cut façades, could be ornamented by a terra-cotta or a bronze lining, because, as a rule, coloured inlays are applied to stone and brick. Moreover, the forms we find here are those invented by the mat and basket maker or the weaver, which he elaborated by opposing strips and threads of various colours to one another. The principle of the Phrygian decorative scheme is the chess-board pattern, met with among people and nationalities the most diverse in the early manifestations of their industries.

(Fig. 126)—or curtains to doorways, to exclude sun and dust and allow free access within as well. Native imagination supposed the decoration of these frontispieces, whether funereal or commemorative, to be one of those richly tinted veils hung up in front of the door—an hypothesis which provided the ornamentist with a theme which he could easily work out as fancy prompted him. It is even possible that the imitation of tapestry was carried further than might be surmised from the present state of the monuments; and that, to bring out the geometric shapes composing the decoration, recourse was had to tinted grounds, red and blue. Vestiges of polychrome ornamentation have not, it is true, been observed about these vast surfaces, but this may be due to the flat relief of the forms, which offered but little protection against the weather. The observations of myself and M. Guillaume respecting Delikli Tach and Kumbet, the only tombs that have been traced by an architect, would tend to confirm the above conjecture.

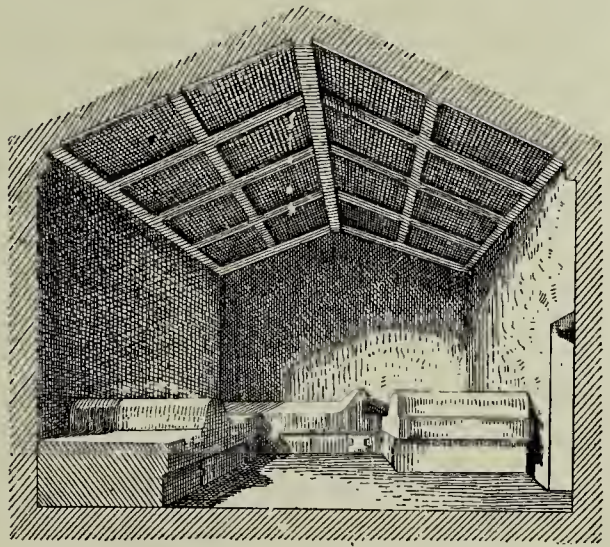

FIG. 126.—Tomb near Iasili Kaïa. Perspective view of main chamber. HEUZÉY, "Recherches sur les lits antiques considérés particulièrement comme forme de la sépulture" (*Gazette des Beaux-Arts*, 1873).

At Delikli Tach (Fig. 56)¹ the whole front was covered with a coat of stucco, where, in the most sheltered parts, painting was still visible. At Kumbet there were no remains of plaster; nevertheless distinct traces of red are distinguishable in certain hollows, especially about the palmettes at the angles. Within the vault, over the second doorway, there appears a kind of Egyptian gorgé, ornamented with red vertical stripes, as part of the cornice (Fig. 89).² Again, in other tombs of the same village (7 in map), we noticed stripes of the same tint which served to divide the wall of the chamber into compartments or panels. The Phrygian ornamentist knew, then, how to use the brush in order to complete or supplement work done by the chisel, and heighten the effect of certain mouldings or paint them on a flat surface. This being granted, is it not at least probable that the stone-cutter, in order to impart more cha-

¹ *Hist. of Art*, tom. v. p. 97.

² PERROT et GUILLAUME, *Explor. Arché.*, p. 168.

racter and effect to these units, the relief of whose form is so slight, had recourse to the same expedient? A few well-chosen pigments were all that was needed to obtain a brilliant decoration, in tones that could be seen from afar, and in imitation of a resplendent veil which the piety of a later generation had hung athwart the rock, in the depths of which reposed the venerated dead.

Some thirty centuries have elapsed since then, in the course of which all that goes to make up the habits, manners and customs, the language and religion of a race, even to the inhabitants themselves, everything has apparently changed many a time in Asia Minor. Nevertheless, the traveller is startled by resemblances as unforeseen as they are curious and frequent between the present he observes, and that past whose image he tries to reconstitute. Should his wandering steps take him northward of the Midas rock, to the little town, now the capital of the canton, in which rises the tomb where are deposited the remains of Seid el-Ghazi, the victorious lord, a saintly hero of Islam, he will find it hung with Turkish or Persian carpets and costly shawls, soft in texture and of brilliant colours. Precisely the same thing is seen about the vault of the mosque at Hebron, where the patriarchs Abraham, Isaac, and Jacob are supposed to rest, but which may have been erected by the Maccabees; and, again, about the turbehs at Broussa and Constantinople, the burial-places of the Osmanlis.

The inference to be drawn from this general employment of drapery is that the Phrygians also veiled those vats or troughs and mortuary couches, found in multitudinous tombs, whose patterns were identical with those carved with so much care on the façades of the monuments. Plates of metal may also have been applied to these frontispieces. We thought to recognize the marks left by them about the sealing-holes of the Delikli façade, towards the top.¹ Should our visual observation be confirmed, it would strengthen the conjecture suggested by a text which does not seem to have been noticed before;² and the question may be asked as to whether bronze figures, analogous to the one referred to above as having stood over the Midas tomb, did not adorn the summit of some of these monuments. But as with the question of the part colour played in the ornamentation, that of metal also, can only be settled by minute and thorough exploration. Should

¹ PERROT and GUILLAUME, *Explor. Arché.*, p. 112.

² *Hist. of Art*, tom. v. p. 182, 183.

this be undertaken by one possessed of the requisite patience, we doubt not but that interesting discoveries would crown his efforts, without prejudice to past labours in the same field. The innate love for colour of nations rejoicing in perpetual sunshine is well known; the data to hand, though scanty, make it probable that the Phrygians formed no exception to the general rule, and that, externally and internally, the sculpture and sombre sheen of metal were relieved by strongly coloured backgrounds. The fancy can picture these multi-coloured surfaces standing out in bold relief from the clear azure sky, the low tones of the rock, and the rich varying greens of the surrounding leafage. Yet all may be illusion and a snare, and until the sculptured fronts have been narrowly examined, bringing ladders or scaffolding in touch with the topmost parts, supplementing vision by "touch," so as to lay hold of the slightest signs of the primitive intentions and dispositions, it would be rash to advance a decided opinion.

That which characterizes the monuments we have just reviewed, or at least those of them the true type of which is to be found in the Midas rock, is the union, in the same unit, of two distinct sets of devices; the one suggested by wooden shapes, and the other by patterns familiar to the weaver and the embroiderer. Nowhere have we met, outside Egypt, nor shall we meet on our path so intimate a blending of two categories of forms, and if there is a Phrygian ornamentation properly so called, it should be approached and defined from this its individual standpoint. Side by side with elements sprung from local habits and indigenous industries are others that may be viewed in the light of importations, as having been transmitted to the Phrygians through the medium of their neighbours of Cappadocia. It was Oriental art which gave them the idea of setting up animal figures at the portals of their palaces, of which the shapeless, unwieldy Kumbet ram is the sole representative (Figs. 115, 116); from it, too, were borrowed lions in pairs, rampant or passant, separated by a pillar, a vase, or other object. We have seen Assyria and Chaldæa lavish these symmetric groups both about the walls of their royal buildings and the woven fabrics they exported wherever a market was open to them. Thence also came feathered sphinxes, whose wings curled in front, and which bring to mind the sphinxes of Anterior Asia, rather than those of the Nile Valley (Fig. 109).

Particularly interesting would be a detailed study of the archi-

tectural forms manifested in these monuments; but in order to do this properly and judge of the nature of the ornamental scheme, drawings on a much larger scale than those to hand would be requisite. Then, too, following up the points in touch which a certain class of capitals seem to have with Ionic, Doric, and Corinthian capitals—albeit not copied on any canonic types of Greek architecture—would give rise to curious remarks. Are the analogies in question previous to the age when Hellenic architecture differentiated and fixed its types, or mere distortions more or less barbarous? We incline to the first

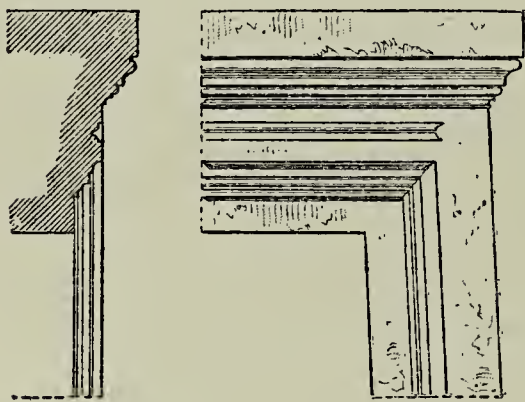

FIG. 127.—Tomb of the Ayazeen necropolis, showing door-frame and profile of its mouldings.

hypothesis. The profiles of the mouldings in all these façades are those of an archaic style rather than one of decay (Fig. 127). Another sign of remote antiquity is the very marked sloping of the jambs about the doorways (Figs. 75, 79, 92). If a certain degree of hesitation may be felt in regard to the calathiform capital, found in very late monuments (Fig. 97), including the exceedingly simple exemplar with a far-off resemblance to the Doric,

this does not apply to those capitals whose forms approach those proper to the Ionic order. The latter are found in tombs, which, like the Yapuldak (Fig. 75), belong to the oldest group of hypogea contained in these necropoles. Here, over the door leading from the second to the third chamber, is a small column with double volute—a detail which was not lost upon the traveller who saw it; but he neither described it with precision, nor was his visual appreciation carried into his sketch, where it is barely outlined.¹ As to the capitals encountered in the Ayazeen necropolis (Figs. 93-96), it is not easy to see in them borrowings from classical models; one is rather inclined to range them in the category of those forms we have called Proto-Ionic, the outlines of which were first observed in Chaldæa and Assyria, and which would naturally come next after the series of those figured in the *ædicula* of Iasili Kaïa, in Pterium.² Thus each

¹ BARTH, *Reise von Trapezunt*, pp. 93, 94.

² *Hist. of Art*, tom. iv. pp. 694, 695, Figs. 314, 321.

day adds to the evidence we already possessed, and tends to confirm the hypothesis formulated by antiquarians, to the effect that the Ionian Greeks found the device in full swing among the dwellers of the tableland and the upper valley of the peninsula. This type they refined and perfected into the beautiful architectural member they were so fond of introducing in most of their edifices; and though they did not actually invent it, they certainly gave it its graceful, charming curves, and deserve to have their name inseparably attached thereto.

If in the course of our analytical retrospect we have not once made mention of vegetable ornament, that is because the Phrygian

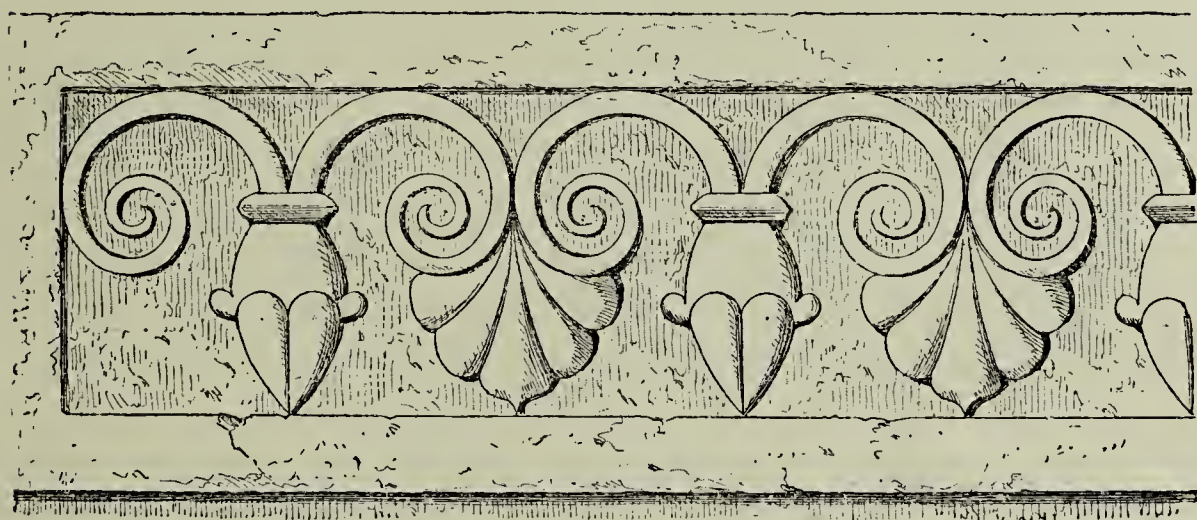

FIG. 128.—Scroll on sepulchral façade. After Blunt.

craftsman rarely derived his decorative forms from the inexhaustible store furnished by the leafage, fruit, vegetables, and flowers of the woodlands amidst which he lived. In this department all we can mention are characterless leaves surrounding the basket-shaped capital (Fig. 97), the mediocre and rudely carved chaplets in the façade of the tomb (Fig. 93), and finally the scroll, executed in good style, which forms a kind of frieze below the frontal in one of the principal monuments of the northern necropolis (Fig. 128). Its arrangement is precisely similar to that of the scrolls formed by the lotus bud and flower, which Assyria seems to have borrowed from Egypt.¹ If the Assyrian artist improved upon his Egyptian model, in that the elements of the group, buds, flowers, and curved lines are better allied one to the other, so did the Phrygian outstrip him. Thus the leaf-stem is replaced

¹ *Hist. of Art*, tom. ii. p. 319, Fig. 134, 136.

by a double volute, which imparts greater amplitude to the ornament. It has already something of the character of those spiral devices so largely introduced on vase-painting by the Greek artist. Was the form we reproduce in the annexed illustration (Fig. 128) derived from an Oriental model? Perhaps so, up to a certain point, and having regard to the very peculiar way narrow shapes are opposed to large ones, as well as to the mode of attachment; but the resemblance to Asiatic art is more intelligible on the hypothesis of imitation than of native ingenuity. Moreover, the rosette, thrice repeated within the field and above the tympanum (Fig. 59), belongs to the "properties" of the Mesopotamian artist. A piece of stuff of Chaldæan manufacture, doubtless, suggested the notion of putting there scroll and rosette. But that which would seem to belong to the Phrygian artisan is his having discarded the flower of the tepid waters of the Nile for the fruit and leafage of the oak and pine, of abundant growth in his native valleys, and a familiar object to his countrymen. As to the spirals curling round the base of the leaf, it may have been induced by direct observation of nature, the tendrils of creepers, which in many a northern district of Asia Minor climb the boles and branches of trees. Such a locality, on the middle course of the Sangarius, is present to me now, which I visited in early spring, when my olfactory nerves were gratified by the delicate sweet perfume which the bloom of the wild vine spread abroad.

To sum up: the chief characteristics of Phrygian decoration would seem to reside in the development of the device under notice, the substitution of the oak for the lotus, as well as the blending of wooden types and tapestry patterns; so that it may justly put forth claims to its share of invention and originality. These merits would certainly be more patent, had any remains of Phrygian industry come down to us—armour, furniture, jewellery, and woven fabrics. Unfortunately the sculpture of the Phrygian race was not sufficiently advanced to trace, as in Egypt and Assyria, the faithful and lasting image of tools, utensils, ornaments, and so forth that served them in their daily life.

The only local industry of which, by the aid of the form seen on the stone façades of the necropolis, some notion may be gained is that of tapestry. But if we are to accept the decoration of the Midas rock as a copy of carpets worked at that time in the villages of Phrygia, we are bound to admit that they were much simpler than

the webs of Egypt and Assyria. The tapestries issued from the workshops of Babylon and Anterior Asia were figured; the borders often taken up by flowers and leaves and long rows of animals, real or fantastic, of whom Orientals have always been enamoured. Here, on the contrary, the patterns are entirely made up of geometrical combinations. Tomb Fig. 89 forms the only

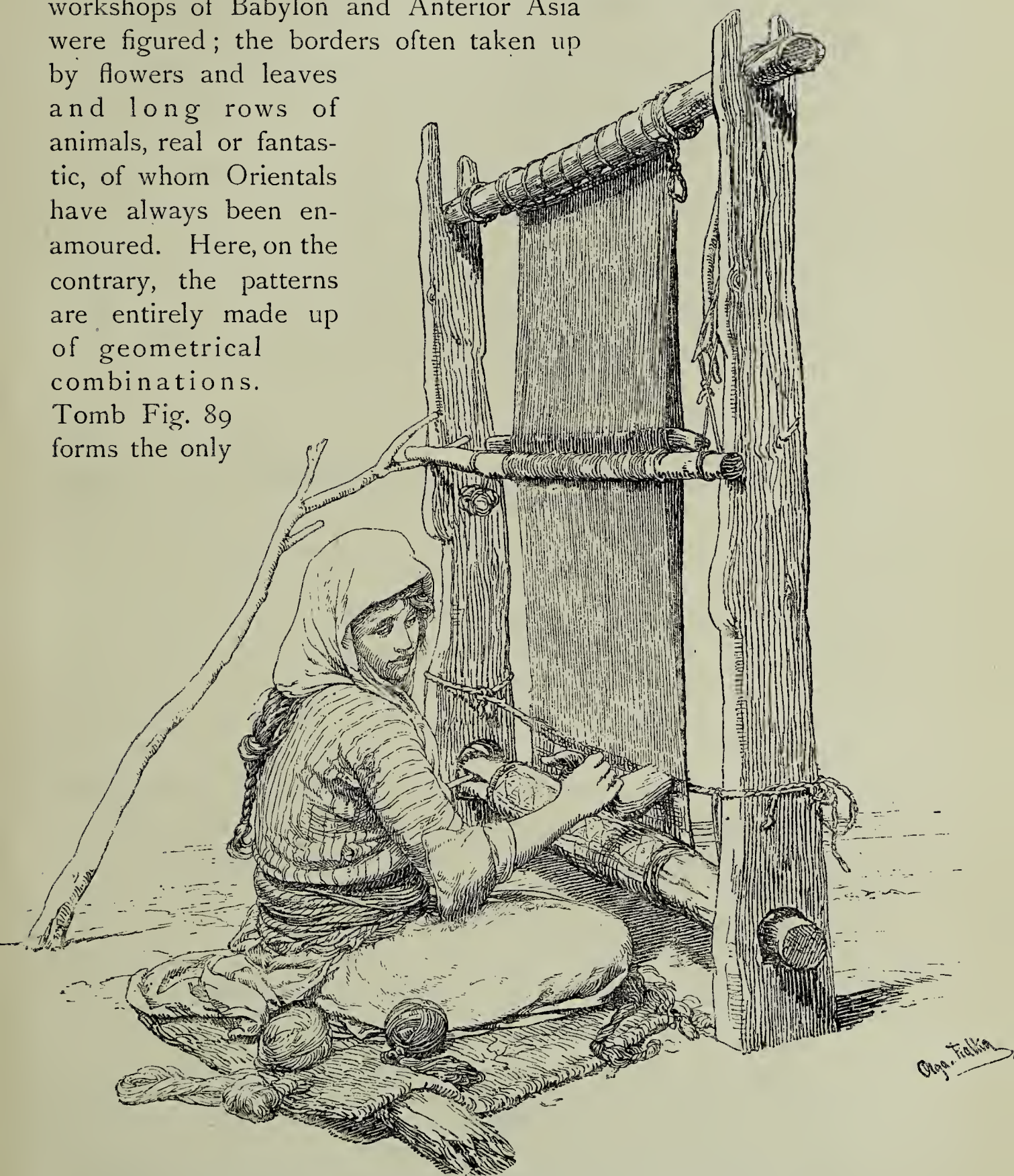

FIG. 129.—Turkish woman at her loom. BENNDORF, *Reisen*, tom. i. p. 18, Fig. 12.

deviation to the general rule; hence we may assume that vegetable ornament took up but a narrow space. Nowadays, whether under

the roof of the stay-at-home Turcoman or the black tent of the nomad, the goodwives are the sole makers of those carpets for which demands have so steadily increased during the last twenty years or thereabouts. In this and other particulars, matters are probably as they were in olden times; nor is the loom, of which two varieties exist, much changed.

The more elementary (?), technically called "high warp," is used for webs of a plain description (Fig. 129¹). It consists of two movable cylinders, supported by uprights which enter the ground, held together by cross-beams. Round the upper cylinder, mortised at the sides, is rolled the warp, and round the other, fitted into holes at the end, the web as this is completed. The



FIG. 130.—Comb of carpet-maker. *Reisen*, tom. i. Fig. 13.

warp is stretched upon the frame and divided by the weaver into two leaves, which are kept apart by a thread passed alternately between the threads of the warp, and by small sticks. The warp consists of balls of coloured wool, some on the ground, others suspended to a cord, stretched across the frame, at the height of the weaver's hand. These worsted threads she dexterously twists and knots, two at a time, into the lengths of the warp. When a series of courses is completed, she strikes the warp from top to bottom with a heavy-handed comb (Fig. 130). The result is a twisted, rather than a woven tissue. The fact is hard to realize that this rude frame is on exactly the same principle as the complicated modern loom, with its array of cylinders, glass tubes,

¹ Our illustration is taken from *Reisen in Lykien und Karien beschrieben*, by Otto Benndorf and Georg Niemann, folio, Wien, 1884; a work from which we shall freely borrow in this part of our volume. The loom figured on p. 189 was photographed by the explorers from one belonging to a Turkish household settled hard by Cnidus. Plate VIII. (*Reisen*) shows a frame akin to this set up in the open near a Iürük encampment. Our verbal description is mainly due to Professor Karabaceck, whose knowledge of Oriental tapestry is well known (*Reisen*, p. 19). We have also consulted Muntz' excellent manual, *La Tapisserie*, 12mo, Quantin (*Bibl. de l'enseignement des Beaux-Arts*).

and tracings on the warp,¹ in which the Gobelin tapestry is manufactured at the present day, with seven or eight skilled artisans at work on the same piece. Nevertheless, guided by racial instinct, the poor Turkish woman, with her imperfect tottering frame, will turn out so marvellous a picture of the native wildness of flowers as will justly rank, in the eyes of a true *connoisseur*, far above the costliest products of Paris or Manchester.

None but high-warp frames have been traced on ancient monuments, an instance of which appears in a painting at Beni Hassan,² whilst Greece furnishes a vase from Chiusi, in which Penelope is figured sitting at her loom with a vertical frame.³ It is probable, however, that the low-warp or flat frame was known in antiquity; in which, as the name implies, the cylinders are horizontal or parallel to the ground, and the crossing of the warp is done by a downward movement of the treadle, which is moved with the foot.⁴ Work made on the horizontal frame is analogous to our calicoes. This frame is used at the present day in those towns of Asia Minor where carpet manufacture has acquired a certain importance.⁵

Phrygian women, writes Pliny,⁶ were the inventors of work done with the needle or embroidery, in which they excelled. Even now, whether along the coasts or in the interior of the peninsula, women adorn their bodices, aprons, and head-coverings, the towels presented to the guests before and after meals, coverlets, etc., with geometric shapes, clustering flowers and leaves,

¹ This is done by means of a transparent paper, on which a sketch of the picture to be copied is countertraced in sections as the work advances.—TRS.

² *Hist. of Art*, tom. i. Fig. 25.

³ The vase in question has been published by CONZE, *Monumenti dell' Istituto Arche.*, tom. ix. Plate XLII. Fig. 1; reproduced by MUNTZ, *La Tapisserie*, p. 31.

⁴ In both looms the weaver is obliged to work on the back of the piece; but as the face is downward in the flat frame, it is much more difficult to detect and mend a fault; for in the vertical loom he can step in front and correct, as he advances, the smallest mistake. With regard to tapestry, woven stuffs, and so forth, the reader will find valuable information in the South Kensington Handbooks—*The Industrial Art of India*, by G. C. M. Birdwood; *Textile Fabrics*, by the Rev. D. Rockford. Consult also HAMILTON, *Researches*, vol. ii. p. 111.—TRS.

⁵ Plate VII. (*Reisen*) has a photograph of one of these primitive frames. It is certainly helpful in giving a general idea of the apparatus, but it would perhaps be difficult to make a satisfactory drawing from it.

⁶ *H. N.*, viii. 74: "Pictas vestes apud Homerum fuisse (accipio), unde triumphales natae. Acu facere id Phryges invenerunt, ideoque Phrygioniae appellatae sunt. . . ."

sometimes threads of gold and silver, formed into picturesque designs, exquisite in tone and workmanship. It is work that will bear being looked into, where nature is reproduced with truth and great freedom of interpretation at the same time; that is to say, the very qualities which tapestry and embroidery should possess.

TOMBS IN PAPHLAGONIA.

In the district whose antiquities we have described in the foregoing pages are monuments proper to it and encountered nowhere else; they cluster around the frontispiece upon which the name of Midas is to be read, and consist of those façades where forms borrowed from timber enframe ornament with forms seemingly imitated from tapestry designs. Such façades are further characterized by inscriptions, the lettering of which belongs to the syllabary we have called Phrygian. If nothing of the kind has been seen hitherto outside Phrygia, *per contra*, in the adjacent province of Paphlagonia, a recent explorer, M. G. Hirschfeld, reports the existence of several tombs exhibiting singular analogies with such exemplars of the Ayazeen necropolis as are adorned by a porch.¹

The name of Paphlagonia was given in antiquity to that portion of the peninsula whose boundary line was formed on the north by the Euxine, the Halys on the east, the Parthenius on the west (beyond which lived the Myrandynians and Bithynians), and Mount Olgassys on the south.² The latter belongs to the Olympus range, whose summits rise between the central plateau and the low valleys watered by streams discharging their waters in the Black Sea. It is emphatically a hilly, well-timbered region, albeit here and there the hills open out into plains of no great extent, but of marvellous fertility, due in part to the abundant

¹ G. HIRSCHFELD, *Paphlagonische Felsengraeber*, etc., with seven plates (*Abhandlungen der Kaiserliche Akademie der Wissenschaften, Berlin*, 1885, 4to).

² Xenophon extends further east the boundaries of Paphlagonia, beyond the Halys and the mouth of the Thermôdôn; perhaps on the testimony of Hecatonymus, the Sinopian envoy at that moment in the Greek camp. Among the many difficulties the Greeks, according to his account, would have to face, he seems to suppose that before they attempted to cross the Thermôdôn, they would have had to fight the whole force of the Paphlagonians (*Anabasis*, V. vi. 9). In another passage (*Ibid.*, VI. i. 1) Xenophon tells of a collision between Greek marauders and Paphlagonians, as having taken place in the neighbourhood of Cotyora.

supply of water, in that the lower range of mountains run parallel to the coast line and oblige the streams to wind round their base ere they reach the sea or lose themselves in the Halys. On the coast, Sinope, a Milesian colony, had been a flourishing centre from the eighth century B.C., and in its turn had given rise to Amastris, Sesamos, Kytoros, Ionopolos, or Abonoutikos. Thus she multiplied havens along the line of coast, in which her merchantmen could take shelter, whence a brisk trade could be carried on with inland tribes.

Lost amidst woodlands, these tribes are little known; nevertheless, it would appear that they were closely related to the Cappadocians, and spoke like these an Aramaic idiom, a fact which permits us to class them with the family of Semitic nations.¹ However that may be, we learn from Xenophon, the first man of note who visited this district before Alexander the Great, that they were less rude and savage than their neighbours, the Tibarenians and the Mosynœci. The Ten Thousand did not traverse Paphlagonia, but took ship and skirted its coast as far as Cotyora, where they encamped. Here their general received the delegates sent by the Paphlagonian chief, Corylas, whose barbarous magnificence and fine steeds drew forth admiring expressions from the Greeks.² The power of Corylas must have been considerable, to judge from the high estimation in which he was held by a city like Sinope, her foremost citizens styling themselves royal guests, pensioners.³ The Sinopian envoys, for private reasons of their own, did their utmost to prevent amicable relations being entered into between the Greek captains and Corylas; hence to dissuade the former from crossing the Paphlagonian territory, they may have exaggerated the military force of the barbarians,

¹ Herodotus, in writing of circumcision and the nations among whom it is practised, goes on to say, "The Syrians, who occupy the banks of the Thermôdôn and the Parthenius . . .;" thus confounding under one denomination the Cappadocians and Paphlagonians. Strabo (XII. iii. 25), whilst stating that many local appellatives are common to Paphlagonia and Cappadocia, bears witness to the resemblance existing between the dialects current on either side of the Halys. PLUTARCH (*Lucullus*, 23) speaks of Sinope as situated in Syrian territory. Finally, Denys Periegetes (v. 970-972) specifies two Syrias—one in Lebanon, the other stretching far away to Sinope washed by the flood, inhabited by Cappadocians.

² XENOPHON, *Anabasis*, VI. i. 2.

³ *Ibid.*, V. vii. 11.

when they affirmed that they could move 120,000 men into the field, including a well-mounted cavalry.¹

The meaning covered by these words is that the powerful maritime centre had every interest to secure the amity of native chiefs, who could at any moment oblige her inhabitants to keep within her walls, and close up the routes followed by her trade with Phrygia, Cappadocia, the distant provinces of the Taurus, and the basin of the Halys. The bulk of her transport, as well as her import traffic, was right through Paphlagonia. Her caravans, laden with all manner of manufactured goods, collected in the workshops of Ionian cities, moved slowly along the circuitous mountain path, distributing them everywhere. They brought back in return not merely hides, but corn and wool; not only mineral substances, such as minium or vermilion, but textiles, bronzes, ivories, enamelled terra-cottas, jewellery—in fact, the whole luxury of the East. Thus was created a flux and reflux which led through the land of the Paphlagonians; so that these could not wholly escape being influenced by two sets of cultures, the Greek and the Asiatic, between which they acted the part of middlemen. The transactions in which they took part brought them in touch with polished nations; similar relations, and the models created by skilled labour thus brought to them, could not but awake in their breasts a taste and feeling for the refinements of life. The fact, therefore, that monuments within the territory of Paphlagonia bear upon them the impress of noble and considerable effort, should cause no surprise.

Towards the centre of Paphlagonia, in a valley which we may well imagine to have been thickly populated from the earliest age, hard by the little town of Kastamouni, Kastamboul, there appears a whole series of tombs hollowed in the depth of a low cliff of a certain length.² Some notion of the general arrangement of the whole may be formed from the annexed plan (Fig. 131). The principal hypogæum (1) is preceded by a portico composed of two square pillars, about 4 m. high, and corresponding antæ. These pillars are without base; above is a rude capital with cavetto and abacus. Over this again an architrave and pediment, which

¹ XENOPHON, *Anabasis*, V. vi. 9.

² The name of Kastamouni does not appear in history until the thirteenth century of our era, but the presence of ancient remains about the place leads to the inference that a settled population had long been established here.

latter has suffered much from the weather (Fig. 132). Within the tympanum, right and left, are winged quadrupeds, whose four paws rest on the ground. The figure separating them appears to be that of a female clad in a long robe. Pierced behind the columns, a door, not quite in the middle of the wall, leads to a rectangular chamber, whose sides are smoothed over with care. The curves of the ceiling, in imitation of a tent covering, should be noticed (Fig. 133). The chisel has reproduced on stone even the rollers which in the light construction uphold the frame.

At the southern extremity of the porch, a small door opens into a second and smaller chamber, whose roof and main beam recall a lignite structure (Fig. 134). The funereal bed is found in a niche, the external face of which is akin to that of a wood panel. Nor does the hypogeum end here; beyond are two steps by which the apartments 3 and 4 are reached (Fig. 135), the last one alone containing graves hewn in the floor. Taken together, these chambers measure 22 m. 7 c. from north to south. All the tombs we have met with in Asia Minor up to the present time had but one, or at most two sepulchral chambers. This is the first instance of a family vault, with its row of graves, like those found in such abundance in Phœnicia and Judæa.

Although imperfectly described,

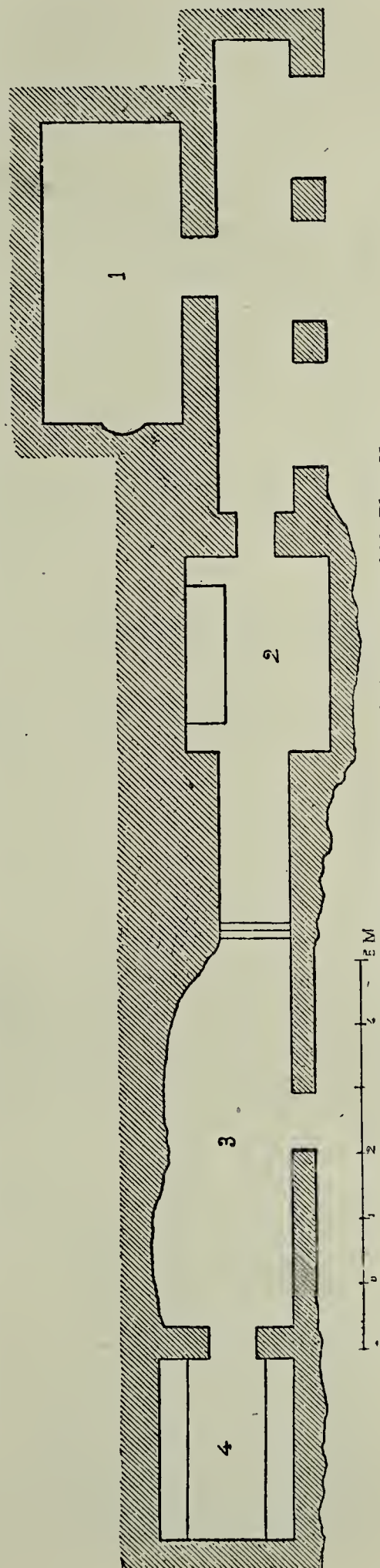

FIG. 131.—Tomb at Kastamouni. General plan. Hirschfeld, Plate V.

the hypogeum was pointed out by MM. Shanykof and Mordtmann, some time before M. Hirschfeld visited it. But he was the first to light upon the tomb called Hambar Kaïa (Barn Rock),



FIG. 132.—Kastamouni. Tomb 1. Frontal. Hirschfeld, Plate V.

situated in a deep valley of the Halys, marked "Terra incognita" in Keipert's map.¹ The vault is hollowed in the northern face of a mass which juts out from the body of the hill, along the right bank of the river, into a kind of promontory (Fig. 136).



FIG. 133.—Kastamouni. Tomb 1. Ceiling of chamber. *Ibid.*

The frontispiece, to the height of 13 m. 70 c., is inwrought with a gentle upward slope, but the lines of the porch by which the chamber is entered have all been maintained in a vertical plane.² The result has been to leave along the whole front, between the talus and the base of the columns, a ledge or step 7 m. long and 74 c. wide (Fig. 137). Above it, by way of balustrade, the rock was cut

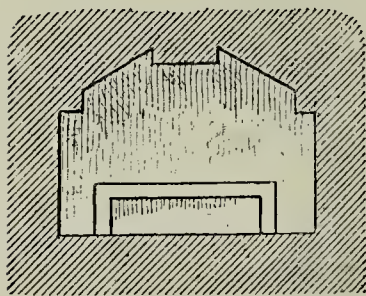

FIG. 134.—Kastamouni. Tomb 2. Transverse section of chamber. *Ibid.*

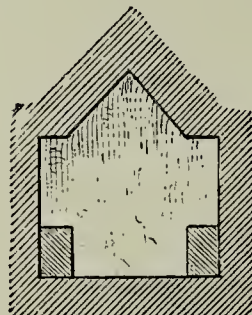

FIG. 135.—Tomb 4. Transverse section of chamber. *Ibid.*

into three lions couchant, seen in profile. Their sides are left in the rough, and adhere to the cliff, whose slope they continue. Except for the back, head, and paws, it would be hard to make out the kind of animal to which they belong. They have suffered very much from the weather; their pose, however, would seem to be pretty near the same as that of those bronze lions which in Assyria served as weights.³ The porch, whose floor is

¹ For a detailed account of the monument and of its geographical position, consult M. HIRSCHFELD, *Memoir*, pp. 9, 11.

² M. Hirschfeld estimates the angle made by the talus with the vertical line at 12° .

³ *Hist. of Art*, tom. iii. pp. 566, 567, Plate XI.



FIG. 136.—Hambar Kaia. Hirschfeld, Plate I.

on a slightly higher level, is enframed by a double fascia; the height of its three columns, including base and capital, measures 3 m. 13 c. (Fig. 138). Their short massive appearance is due to the marked diminution of the shafts towards the top.¹ The base is a very large torus and narrow listel; the capital, which is quadrangular, consists of three platbands put one upon the other; their salience beyond the shaft, even the topmost, is very feeble. A mere outline served to distinguish the pediment which stood over the portico from the surrounding rock; there is no cornice to define and shelter its field, so that wind and rain have played havoc with the figures carved on the inclined surface. Distinguishable with the first morning light, however, are a bird at the left angle of the frontal, and a quadruped, seemingly a lion, in front of it. The decoration was in all likelihood symmetrical—an hypothesis borne out by the fact that remains of outline are visible on the other side, where we may suppose that bird and lion were repeated (Fig. 139). The door is neither central with the porch, nor with the apartment to which it gave access. The sepulchral chamber is quite plain, with a roof-like sloping ceiling, and a recess or mortuary shelf pierced in the further wall, 55 c. above the soil, and 95 c. wide. The monument stands well. The architect entrusted with the building was singularly happy in the selection of the site, high up in the cliff, overhanging the flat stretch below. The rude proportions of the columns harmonize

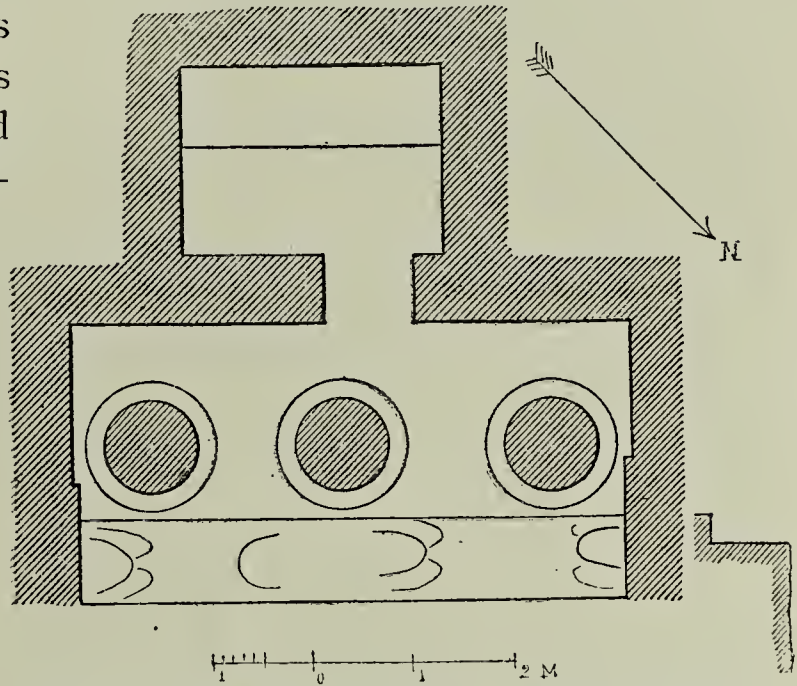

FIG. 137.—Hambar Kaia. Plan of tomb. Hirschfeld, Plate V.

so that wind and rain have played havoc with the figures carved on the inclined surface. Distinguishable with the first morning light, however, are a bird at the left angle of the frontal, and a quadruped, seemingly a lion, in front of it. The decoration was in all likelihood symmetrical—an hypothesis borne out by the fact that remains of outline are visible on the other side, where we may suppose that bird and lion were repeated (Fig. 139). The door is neither central with the porch, nor with the apartment to which it gave access. The sepulchral chamber is quite plain, with a roof-like sloping ceiling, and a recess or mortuary shelf pierced in the further wall, 55 c. above the soil, and 95 c. wide. The monument stands well. The architect entrusted with the building was singularly happy in the selection of the site, high up in the cliff, overhanging the flat stretch below. The rude proportions of the columns harmonize

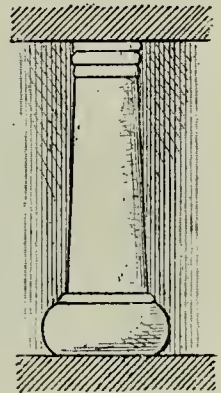
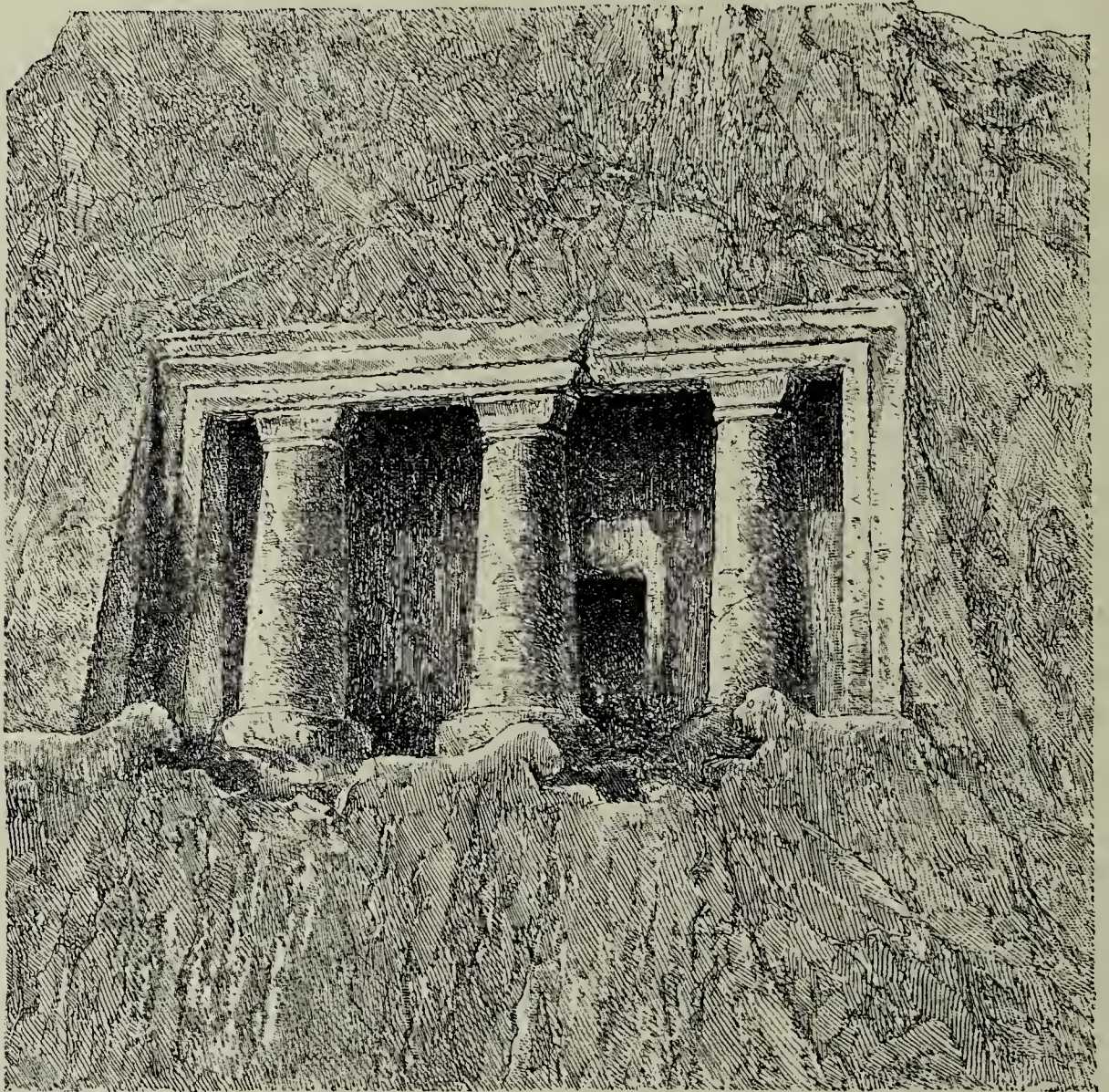

FIG. 138.—Hambar Kaia. Column. *Ibid.*

¹ The upper diameter is 19 c. less than the lower, a considerable difference in a height of 2 m. 19 c. measured by the shaft.

with the amplitude of the rock in which they are carved. The eye is forcibly drawn to their light colour, and when there, it lingers to note the skilful contrast between the polished fasciæ and the sombre rugosity of the virgin rock, between the incline of the talus and the perpendicular lines of the architectonic whole. No



ADAMSON 1872

FIG. 139.—Hambar Kaia. Façade of tomb. Hirschfeld, Plate II.

less remarkable is the shape of the monument itself, terminating as it does in a triangular pediment, which, despite irregularity of outline, recalls the classic frontal.

The Iskelib group, the last of the series, is farther away from the sea, on the edge of the central plateau. It is called after the town of the same name, situate southward of Kutch Dagh, a little way beyond the left bank of the Halys. The tombs are excavated in the depth of a huge rock, towards the base, bearing on its



FIG. 140.—Iskelib. General view. Hirschfeld, Plate III.

summit walls, which M. Hirschfeld identifies with Tavium, the capital of the ancient Trocmes, or Eastern Galatians.¹ As for ourselves, we find no reason to change the opinion formulated in another place, to the effect that the site of Tavium must be sought on the right bank of the Halys, close by Nefez Keui.² Whichever view may be taken, the fact remains that the Iskelib tombs are anterior to the occupation of the district by the Galatians.

There are four sepulchral chambers, one on the ground-floor and the other three on

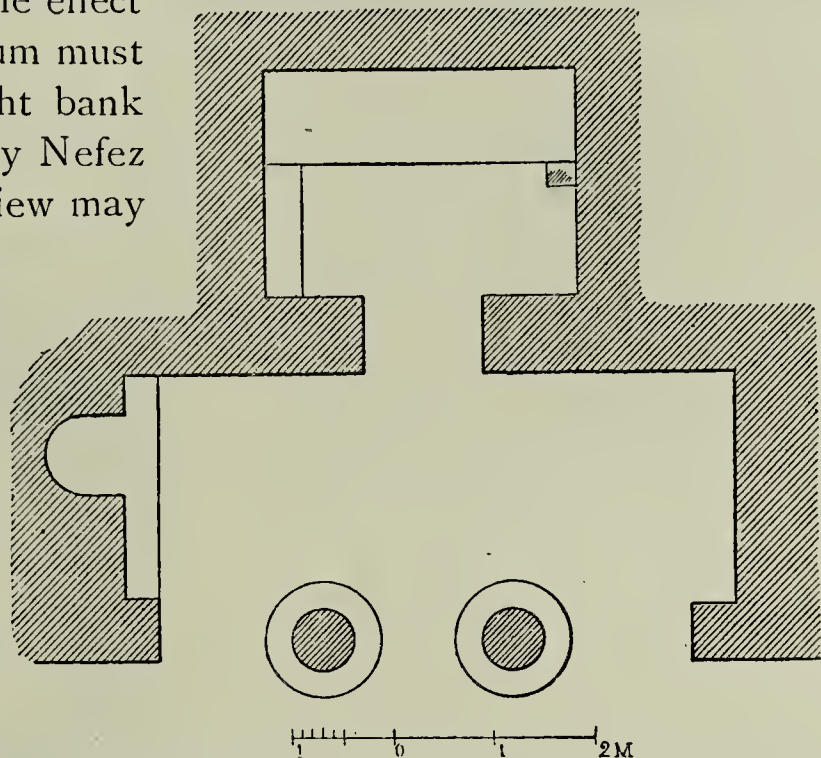

FIG. 141.—Iskelib. Tomb I. Plan. Hirschfeld, Plate VI.

the second tier; the more important one being in the centre (Fig. 140). It is preceded by a porch composed of two stout columns and corresponding antæ (Fig. 141). The whole height of the pillars is almost 3 m.

(2 m. 98 c.), of which 57 c. go to the base and 29 c. to the capital. The base, though a trifle more complicated than the Hambar Kaïa exemplar, is likewise bell-shaped (Fig. 142), and

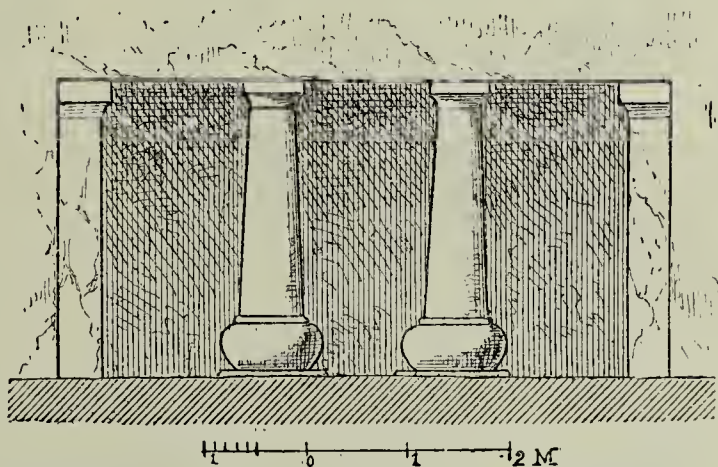

FIG. 142.—Iskelib. Tomb I. Elevation of portico. *Ibid.*

rests upon a thin plinth, 93 c. at the side, a narrow listel uniting

¹ *Monatsberichte Akademien Berlin*, 1884, p. 1254. Ainsworth is almost the only modern traveller, besides Hirschfeld, who visited Iskelib. But he does not seem to have had an inkling of the importance of these monuments; at any rate, no trace of it appears in his narrative.

² PERROT et GUILLAUME, *Exploration archéologique*, tom. i. pp. 289-292.

it with the shaft. The resemblance extends to the capital, likewise on a rectangular plane, made up of a slightly salient cavetto and abacus. The architrave is a smooth flat band; above it appears the pediment, which is wrought with care and slightly sunk. An indistinct object, figure or pillar, occupies the middle of the frontal, the upper part of which has been wantonly destroyed; hence no decided opinion can be advanced as to the nature of the symbol from the least telling portion (Fig. 140).

The vault is spacious, and nearly half of it is taken up by a grave in touch with the end wall. Its vault-like ceiling and the profile of the mortuary couch should be noticed (Fig. 143). A diminutive shelf is pierced on a lower plane along the left wall. The situa-

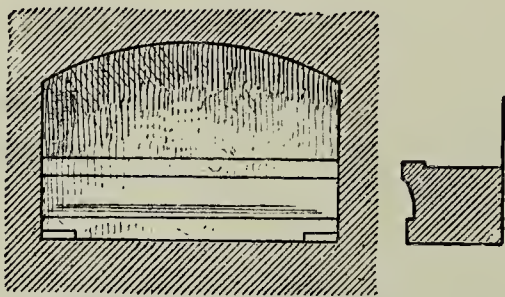

FIG. 143.—Iskelib. Tomb I. Transverse section through end of chamber, and profile of mortuary couch. Hirschfeld, Plate VI.

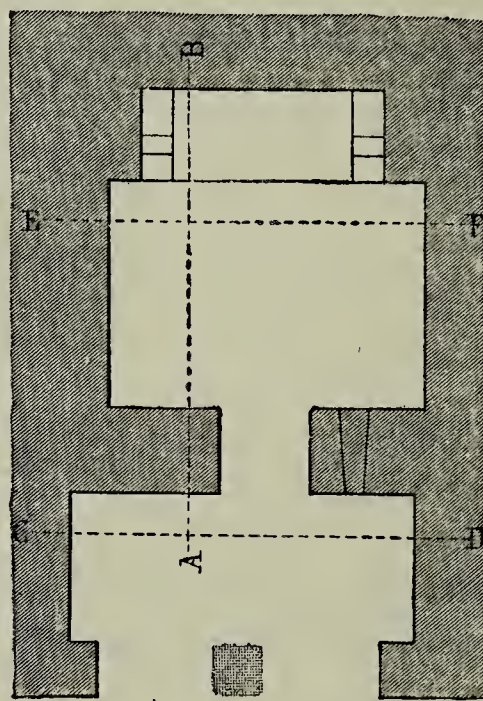

FIG. 144.—Iskelib. Tomb III. Plan. *Ibid.*

tion of the tiny grave at the entrance of the porch on the right-hand side is doubtless the reason of its present poor condition (No. 2). In the lower tomb (No. 3) the one pillar of the vestibule has disappeared; traces of it, however, are visible about the floor and the lower face of the architrave (Fig. 144). The support was removed to facilitate access to the adjoining room and the esplanade, when the tomb was turned into a domestic abode. The mutilation is all the more to be regretted that the work, to judge from the listel framing the end wall, shows careful manipulation (Fig. 145). Base and capital might have yielded interesting details. A door opens into the first chamber,

lighted by a narrow window; the diminutive apartment seen behind it is the grave properly so called. Both have roofs with sloping sides; but the slightly projecting band, which in the main chamber serves as point of junction between the vertical walls

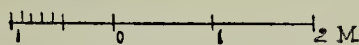
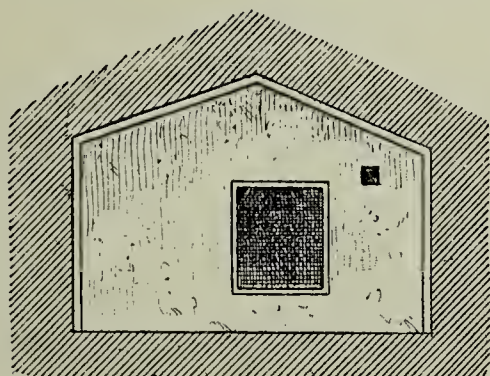

FIG. 145.—Iskelib. Tomb III. Transverse section under porch through C D. Hirschfeld, Plate VI.

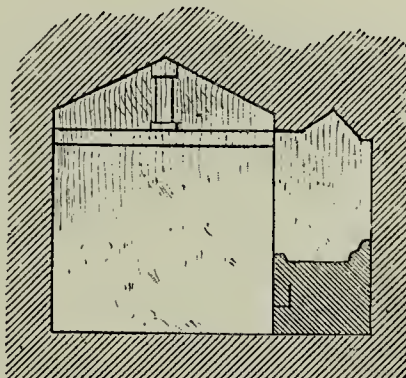

FIG. 146.—Iskelib. Tomb III. Longitudinal section through A B. *Ibid.*

and the superincumbent ceiling, is not repeated in the smaller tomb (Fig. 146).

As in many Phrygian tombs, we find here also a pillar in the middle of the tympan, which is an exact copy of the wooden post of a loft. Like it, it is composed of a thin plinth or

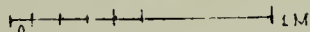
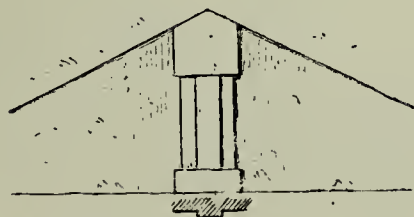

FIG. 147.—Iskelib. Imitation of a wooden loft. *Ibid.*

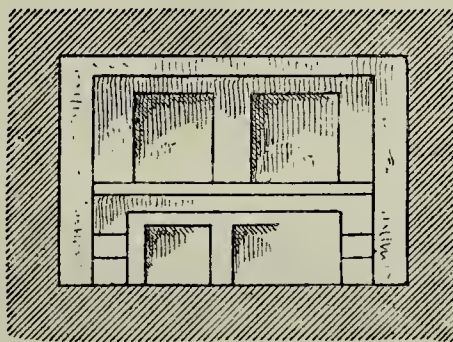

FIG. 148.—Iskelib. Tomb III. Section through E F. External face of mortuary couch. *Ibid.*

shoe, three square posts, and the whole is topped by a capping upon which rest the cross-beams (Fig. 147). Again, the ceiling of the further room forms a canopy over the anterior face of the grave, divided into four panels like a wood partition, and as unlike stone forms as can well be imagined (Fig. 148). This applies to the shelf, 60 c. wide, upon which the body was laid; its outer rim is rounded off, whilst the two semi-rolls at the back stand out from the rocky wall. All these details show care and finish.

The fourth tomb, whose base is about three metres above the

ground, stands somewhat apart to the westward of the group we have just described. Its general arrangement is precisely similar to that of the other tombs; but its state of preservation is not so good, nor does it favourably compare with any of them in point of workmanship. The interest which attaches to the monument

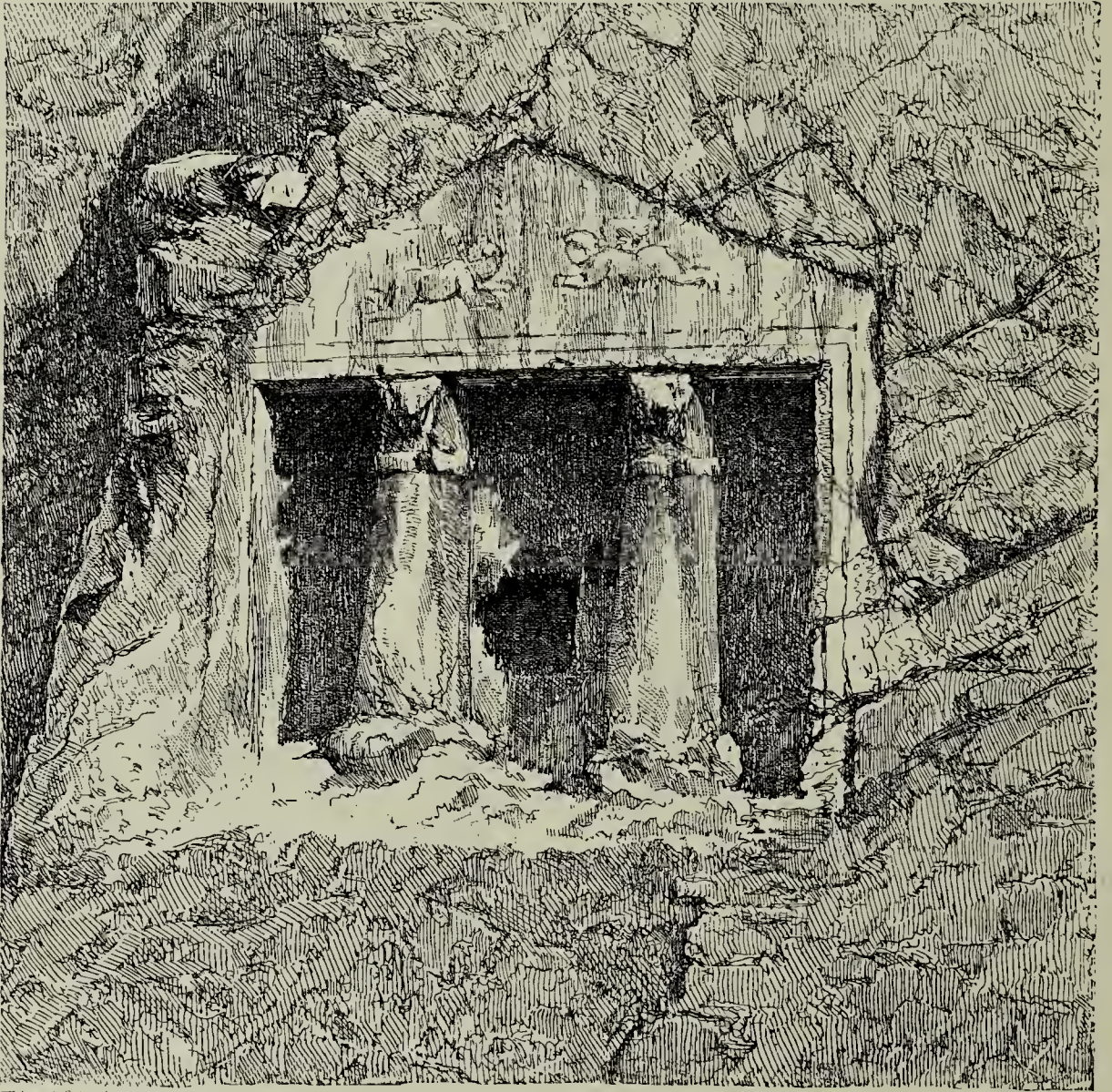

FIG. 149.—Iskelib. Tomb IV. View of façade. Hirschfeld, Plate IV.

resides in curious details, of which more anon, not encountered hitherto in Phrygia nor Paphlagonia.

The portico is enshrined, as at Hambar Kaïa, in a double fascia (Fig. 149). The rude columns, 2 m. 80 c. high, resemble the stems of coniferous trees, and, like these, taper towards the top. The upper diameter of the shaft is one-third less than the lower (95 c.): to this fact the supports owe their squat and massive appearance. The bases are much injured. There is no sign of

plinth or listel; nothing but a very salient torus *cir.* 1 m. 40 c. in diameter. The most striking detail appears in the rectangular capitals, 50 c. high, 95 c. at the side, and 73 c. on the face. Upon this are carved the head and paws of an animal, which M. Hirschfeld thinks were intended to represent a lion. The whole is much worn.

The bases and corresponding antæ—the latter absolutely void of moulding—fill up the whole depth of the porch, so that no passage exists between them and the wall behind (Fig. 150). A niche, irregularly shaped, occurs at the end of the gallery on the right-hand side. A doorway, 80 c. in height, leads to a

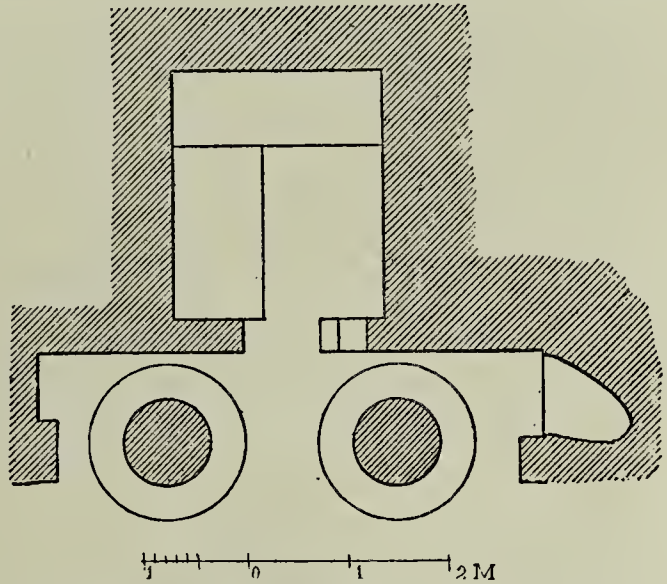

FIG. 150.—Iskelib. Tomb IV. Plan. Hirschfeld, Plate IV.

narrow grave-chamber, whose altitude, measured from the central point of the vaulted ceiling, is barely 1 m. 80 c. (Fig. 151). A stone bench runs along the left and the back wall; and near the entrance was pierced a mullioned window in the shape of a cross.

It remains to notice some curious points about the pediment. Like the Hambar Kaïa exemplar, it is quite plain, without a cornice, a mere isocèle, 1 m. 25 c. high; a light *resault* alone separating it from the rough surface of the rock (Fig. 149). One is surprised to see here two winged *putti*, carved in flat relief within the tympan, and turned towards each other. In the hand of one is carried a label, a fruit or vase in that of the other. Owing to the indistinctness of the details, it is impossible to say which. The pose of the figures, seeming to fly across the solid pediment as in mid air, is incongruous, and ill agrees with the simple and sober taste of remote antiquity. This is one reason for suspecting that the decoration is younger than the tomb. The impression thus created is strengthened by the character of the subject, in which no one can fail to recognize a Greek *Ἔφεος*;

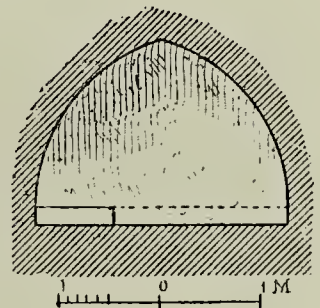

FIG. 151.—Iskelib. Tomb IV. Transverse section through back of vault. *Ibid.*, Plate VII.

a commonplace device the ornamentist of the Lower Empire introduced wherever he found a bare corner.¹ Indeed, the bas-relief betrays the ease and freedom, the nerveless make of the Roman period. This detail apart, the Iskelib tomb is precisely similar to the monuments with which it has been compared; like them it bears the stamp of an age when the influence of Greek culture had not yet made its way into the interior of the peninsula. The conclusion which forces itself upon the mind is that the cupids are an addition of the second or third century of our era, when the long-abandoned tomb received a new tenant. The so-called vault of Solon in Phrygia (Fig. 89) is a conspicuous and certain example of one of those tardy misappropriations. Thanks to this procedure, a man could give himself the luxury of a rich place of burial at little or no cost. All he had to do was to excavate a second chamber, restore the façade, write an inscription over the doorway, and the thing was done.²

The artist found here, as at Kastamouni, a pediment altogether devoid of ornament, and his horror *vaccui* prompted him to fill in the space with figures, that would rejuvenate the monument and clothe it in the fashion of the day.

Along with these should be ranged first a tomb found at Tokat in Pontus, with a small and irregular chamber, and porch upheld by a single pillar;³ besides two other monuments, which seemingly belong to the same series. They are encountered in Paphlagonia: one near Tach Keuprū, ancient Pompeiopolis, the other close to Tshangri, formerly Gangra.⁴ All these monuments belong to a region which is pretty fairly delimited by history and geography; albeit these are not their only claims to be classed under one head. If, in some respects, they recall exemplars already met with either in Cappadocia or Phrygia, their resemblance to one another is so great, that had they not been found closely packed together, one would have been led to put the same label over them. A primary feature they have in common is that in Paphlagonia we see no traces of precautions

¹ M. Hirschfeld (BENNDORF, *Reisen in Lykien und Carien*, tom. i. p. 80) observes in regard to a large sarcophagus, scarcely as old as the Antonines and found at Sidyma in Lycia, that nude winged figures form the acroteria of the frontal depicted upon it.

² *Hist. of Art*, tom. v. pp. 135, 136.

³ HIRSCHFELD, *Paphlagonische Felsengräber*, p. 24, Plate VII. 3.

⁴ *Ibid.*, p. 25.

taken to conceal or render access to the mortuary chamber difficult, as is the case in the older Phrygian tombs ; graves with wells are non-existent. Then, too, throughout Paphlagonia, porches are the due accompaniment of tombs of some importance, and are generally associated with a rudimentary, unadorned pediment ; a characterless outline alone interposing between it and the uneven surface of the rock. But in Phrygia the pediment only occurs in tombs upon which the word "recent" might be written, and are always enframed in a cornice more or less salient, which continues that of the entablature. And again, in the Paphlagonian façades, pillars sufficiently resemble one another to permit of their being classed in one distinct order ; whilst if we except Fig. 149, in which a lion's head forms the capital, base and crown are nearly alike. In the Ayazeen necropolis, however, where scores of tombs are adorned by porches, the

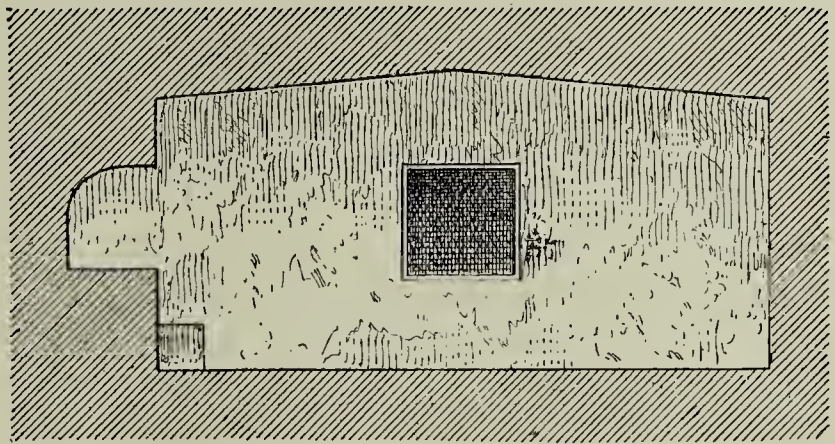

FIG. 152.—Iskelib. Tomb I. Section under porch.
Hirschfeld, Plate VI.

shape of supports is exceedingly varied. Nor is this all ; mortuary couches are by no means the rule in Phrygia, whilst in the basin of the Halys scarcely a tomb is without them. Here, too, doors are all on the same pattern—a small opening devoid of ornament, nearly always rectangular, and *cir.* 1 m. above the ground (Fig. 152). In Phrygia portals are much taller, trapeziform, on a plane with the portico, and wreathed in a frame made up of several mouldings.

It follows, therefore, that the craftsmen who fashioned the tombs at Hambar Kaïa and Iskelib had no hand in building the monuments met with in the upper valley of the Sangarius on the Phrygian plateau ; their habits are not precisely similar, and preference is given to other arrangements. Externally, the Paphlagonian ornamentist does not make use of certain themes, such as patterns derived from tapestries, which are so popular with his Phrygian colleague. What most resembles the hypogea of the Paphlagonian group is the tomb of Alajah, situate on the

right bank of the Halys, in Western Cappadocia.¹ Its size and general disposition, everything, brings to mind that which we have just described; if no frontal appears above the architrave, a decorative form occurs over the window of the side chamber, whose value is precisely similar. Instances observed here are reproduced in the small tomb at Tokat; their significance is sufficiently great to constitute a special type, which we propose to call the northern type of the Asiatic tomb.

The type has an individuality *sui generis*, albeit in many respects closely allied to that which we have studied in Phrygia. Nowhere is this more conspicuous than in the position and general aspect. Here as there, a happy instinct presided over the choice of the rocky masses, in whose flanks tombs were to be hollowed; it warned the architect to put his façade neither too far nor too near the spectator; it taught him the height at which it would dominate the plain and produce the utmost effect.

A distant likeness is apparent between tombs of widely different arrangement; Hambar Kaïa and Delikli Tach, for example (Fig. 50). The upper contour of the stone is wrought in the former, and left in its native ruggedness in the latter. In both a rude frontal follows in a general way the movement of the architectural composition, and serves to separate shapes created by art from shapes traced by nature itself. Both testify to a far more ephemeral style of architecture than could be derived from stone buildings, be it in the outline of frontals, the mouldings of entablatures, the form of ceilings, the arrangement of capitals, the division into panels of vertical surfaces, the extent of which will require ornament. The same symbols obtain in the north and the centre of the peninsula. Thus the lion, which in Phrygia is placed high up on either side of the tomb to guard the entrance, crouches here before the portals (Fig. 136). Elsewhere he has taken his stand on the top of pillars, the better to watch the approaches to the abode of the dead (Fig. 149). At other places animals in pairs appear face to face in the field of the pediment; now a lion and a bird are brought together, now griffins separated by a female figure, who is no other than the great goddess, the tamer of feræ (Fig. 132). One and all of these motives passed under our eyes when we visited the Phrygian necropolises. Within certain limitations, then, the funereal monuments of Phrygia and Paphlagonia may be

¹ *Hist. of Art*, tom. iv. vol. ii. Figs. 344-347.

rightly considered as constituting, to use the language of naturalists, a genus, which comprises not a few species. Many a conjecture on the origin of this local art and the probable date of its chief works, many a remark as to style and peculiar characteristics of workmanship, are equally applicable to the two series we have been led to form and place side by side.

GENERAL CHARACTERISTICS OF PHRYGIAN CIVILIZATION AND ITS INFLUENCE UPON HELLENIC CULTURE.

Some surprise may be felt that so large a space should be apportioned to the Phrygians in this study. Our line of conduct was prompted by the historical part this nation, viewed in the light of recent discoveries, has suddenly acquired in the estimation of antiquarians. For some time past science has busied itself in drawing up the inventory of the benefits the Asiatic Greeks, from the earliest days, derived by contact with their continental neighbours, the numerous tribes they found established on the soil of the peninsula. The task was rendered exceedingly difficult because the peoples which at one time divided Asia Minor among themselves have not sown and left everywhere, as did the Phœnicians, the instances of a brisk and thriving industry. If in the days afar off armour, jewellery, domestic furniture, etc., were deposited in their tombs, these have long been empty. Hence it comes to pass that, in order to divine the inner meaning of their creeds, manners, and customs, we are fain to turn to the rocks they fashioned, the chambers they hollowed in their depths, the sculptures they chiselled, *e.g.* where these have not been obliterated by the weather. Tombs in Lycia may certainly be counted by hundreds, or rather thousands; but nearly all belong to what we have called the second period, and betray the influence of Grecian arts. Of the activity of the Pamphylians and Carians, nothing remains but a few tombs imperfectly traced, and short inscriptions that still await decipherment. The once rich and populous Lydia is represented by a single group of tumuli and her coins. The kingdom of Gordios and Midas did not play so grand a figure in the old world as that of Alyattes and Crœsus, but yet it can boast of rock-cut monuments so plentiful and varied as to enable the student to arrive at a pretty fair notion of the peculiar genius of

its people and the help they gave in handing on plastic types and indispensable industries.

The first thing to be determined is the nature and importance of the borrowings the Phrygians made from the culture of Syro-Cappadocia, whence they seem to have derived the main elements of their beliefs and those rites which Greece long afterwards acknowledged as having received from Phrygia. The Asiatic Greeks who lived in daily intercourse with the Phrygians were content to adopt the sacred orgies they found in full swing among this people, without troubling themselves as to their cradle-land. Our curiosity is more exacting; it aims at tracing back their origin, and the evidence it finds on its path leads irresistibly to Cappadocia. If we have understood them aright, the great figured decorations carved upon the rocks of Pterium reveal concepts and represent ceremonies the main lines of which are precisely those that are supposed to characterize the religion of Phrygia. If we are unable to give a name to one of the two deities, that with the turreted head-dress, long robe, and supporting lion may unhesitatingly be regarded as the prototype of the Cybele of Sipylus and Dindymus.¹ Dances analogous to those of the Græci-Galli are depicted in the procession; some of the actors in the pomp bear a strong family likeness to those eunuch-priests who held the first rank in the sacerdotal order of Cybele. Be that as it may, self-mutilation did not originate with the Greeks, or with any Aryan people whose usages are known to us. It is a rite proper to Syrian cults, and was practised by the Semites, the White Syrians of Herodotus, established beyond the Halys, from whom it passed to the Phrygians. As much may be said of the phallus, put over Phrygian and Lydian tombs alike; were proof required of its importance we could point to the situation it occupies in an *ædiculum* carved upon the walls of the Cappadocian sanctuary.²

If the Thracian tribes in spreading eastwards compelled the Syro-Cappadocians to recede before them, only slowly and by degrees did they succeed in displacing them on this side of the Halys, in the course of which they became imbued with the social

¹ *Hist. of Art*, tom. iv. vol. ii. Fig. 320. The question may be asked as to whether we should not recognize a Cybele, under a different form, in the very curious figure at Iasili Kaia, in which the arms and legs of the deity are made up of lions' muzzles and bodies respectively.

² *Ibid.*, Fig. 331, pp. 385, 646, 653.

and religious ideas of the conquered. It is even possible that certain groups of the old population kept their ground in the neighbourhood of the sanctuaries they had consecrated, and that with revolving years they mixed and were so intimately fused with the new-comers, as to be undistinguishable from them. As we have just said, they transmitted to the younger nation their idea of the divine principle, the practices with which the gods were honoured and the symbols that served to translate their notions of them. The legacy handed down by an alien race was the basis upon which Phrygian genius worked, but which it seems to have enriched and unfolded in such a manner as to deserve to have its name linked with that religion and cultus of Cybele and Atys, to which the Græco-Roman world reserved so long and brilliant a career.

Types and emblems such as these were probably not the only means of expression the Phrygians received from the primitive owners of the land. When they wished to fix their ideas, the only possible system of signs offered to their use were Hittite hieroglyphs, whose finest specimens occur in the inscriptions found in the valley of the Orontes. If writing was known to the subjects of Tantalus, these were the characters they employed. Was theirs the hand, or that of the preceding generations, that engraved in the flank of Sipylus the hieroglyphs still to be seen near the Pseudo-Sesostris and the so-called Niobe? We incline to the latter hypothesis, and ascribe to the Hittites the few cognate signs met with in the very heart of Phrygia, close by long inscriptions in Greek letters.¹ What cannot be attributed to a people whose writing was little more than a string of images are those characters we discovered upon a tomb which, like the Delikli Tach example, unquestionably belongs to the Phrygian series of monuments (Fig. 57). The letters in question belonged to one of those Asianic alphabets, derived, as the Cypriote, from Hittite hieroglyphs through a method analogous to that which gave birth to the Phœnician syllabary.² Consequently there was first a Phrygian alphabet before that represented by the inscription of the Midas monument and others of the same type, in common use at the time when the Phrygians had no teachers outside their eastern neighbours, the Cappadocians.³

¹ *Hist. of Art*, tom. iv. Fig. 553.

² *Ibid.*, p. 519.

³ We are at one with M. Hirschfeld in considering Cappadocia in the light of

Thought has means other than writing to express itself; so that the Phrygians learnt yet another lesson at the Hittite school, and derived from it the first rudiments of art. Their princes, however, even in the heyday of their power and prosperity, do not seem to have been moved by the lofty ambition which had fired the tribal chiefs beyond the Halys. But these, in their encounters on the battle-field and their transactions of a more peaceful character, had been brought in touch, albeit transiently, with the wonders of Egyptian and Mesopotamian culture.

To sum up: Phrygian art stands as near as possible to Hittite art, as this does to that of Chaldæa and Assyria. It is the attenuated reflex of a far-off focus of light, whose rays have of necessity lost much of their splendour during their transit across the mighty Taurus range. Take for example the palace, the masterpiece of Assyrian architecture, represented in Cappadocia by edifices such as those at Boghaz Keui and Eyuk; these, though plainer and on a reduced scale, reproduce the plan and special details of the Ninevite buildings. On the other hand, no such data have been traced in the ruinous structures of Phrygia, so that the question arises as to whether its tribal chiefs were not content to put up with a wooden dwelling. The Kumbet ram (Figs. 115, 116) is the one solitary instance which seems to indicate that an attempt was made here to reproduce a disposition to which Eastern builders were most faithful. But even so, it is not proved that the said ram was one of those janitors we have met everywhere at the threshold of royal mansions, from Persia to Cappadocia.

The same impression is produced when we oppose Oriental to native sculpture. Whatever its purpose, the Kumbet ram looks shapeless as against not only the noble winged bulls at

an important centre of culture (see *Die Felsenreliefs in Kleinasien und das Volk der Hittiker*, p. 70). We deeply regret that his memoir, aptly entitled *Zweite Beitrag zur Geschichte Kleinasien*, should have appeared after the publication of our fourth volume. His observations and deep insight are of the kind that cannot be passed over lightly, and could not but have been of service to us; whilst we should have been at pains to explain more fully the reasons which lead us to differ from him. We might perhaps have been brought to agree on many a point respecting which disagreement is more apparent than real. The only serious point of dispute between us is that Cappadocia and Syria are more intimately connected than M. Hirschfeld is willing to admit.

Khorsabad and Nimroud, but the Boghaz Keui lions, and the Eyuk bull as well.¹ Besides, this fragment is isolated, for no other has been found in Phrygia; all the other instances of its statuary consisting of figures that are one with the mass in which they are carved, and all are modelled on those images in high, moderate, or flat relief, which the primitive owners of the soil chiselled in the flank of the hill. Again, is there aught that in any way resembles the remarkable bas-reliefs of Pterium, whether in magnitude, the number of the figures, or quality of workmanship? The only attempt in that direction is the inexpressibly poor and barbarous hunting scene depicted on the flanks of the Kumbet ram (Figs. 115, 116). The two idols of Cybele (Figs. 107, 110) are of the nature of highly conventionalized symbols, rather than portraiture of the living form. Of the original aspect the colossal Cybele at Magnesia² may have offered, it is now impossible to judge, save that such gigantic proportions as these testify to rare boldness of chisel.

In Phrygia, on the contrary, both in sanctuaries open to the sky and subterraneous chapels, the simulacra we have found are but clumsy, timid pieces, devoid of the one quality of size. As to the bas-reliefs of the Broken Tomb (Fig. 117), and more particularly the images decorating the walls of another sepulchre of the same group, they cannot be discussed here, since they already betray the influence of Greece.

Viewed as disciples of Cappadocian culture, the Phrygians are much inferior to their masters. The fact, however, that they were humble imitators and pupils is undeniable. Method and habit in attacking the solid rock in order to bring out the image, and, above all, identity of types, everything, proves it. The seated Cybele holding a patera (Fig. 107) is a replica of the Sipylus example;³ as to the lions the goddess caresses (Figs. 64, 84, 110),⁴ the notion of making them her companions did not originate with the Phrygians. Another point still more significant and equally foreign to the soil is the oft-recurring device about Phrygian frontispieces made up of two animals, one on each side of some object. This object may be a phallus (Fig. 75), a pillar (Fig. 109), a vase (Fig. 84); the animals, winged sphinxes (Fig. 109), bulls (Fig. 75), and oftener lions (Figs. 64, 84). The artist is allowed

¹ *Hist. of Art*, tom. iv. Figs. 298, 339, 340.

² *Ibid.*, Fig. 365.

³ *Ibid.*, tom. iv. Fig. 365.

⁴ *Ibid.*, pp. 650, 651.

a certain latitude as to the posturing and elements of his group, subject to one condition, that it shall be without prejudice to its general character. The lion device stands out amongst all others as that most dear and familiar to the Assyrian ornamentist.¹ It is the one he lavished wherever he found a space, both as decoration of his palaces, furniture, textiles, and jewellery. Caravans carried the latter to the nations of the West, so that the device became fashionable throughout Asia Minor. From Cappadocia it passed to Phrygia; thence, step by step, it reached Greece, where it obtained civic rights.

Of the animals thus brought in relation and opposed to one another in this theme, some, the sheep, the ox, and the horse, were indigenous, and could be copied from life. Pure creations of the fancy, however, were certainly borrowed from their inventors. Such would be the winged sphinx which occupies the middle of the frontal in the façade of a chapel (Fig. 109); such the griffin (Fig. 108) in the flank of this same rocky mass. The wings of the sphinx are designed like those of Assyria, and more particularly Phœnicia; their tips are curled in front towards the head of the animal.² As to the lion, he would seem to be a borrowed type.

To judge from certain details, notably the treatment of the mouth, it is clear that the sculptor had never beheld the animal, or, at least, had never looked him narrowly in the face with the intention of making his portrait. Silhouette and general outline were taken from Cappadocian artists; these in their turn had been inspired from the models furnished by Assyria. Assyria, with her vast jungles swarming with ferine, her royal hunts at which they were brought down by dozens, alone lived, if we may so speak, in intimacy with the lion, and could thus hit off his physiognomy. The type she had created was offered to the gaze of the Syrians in countless structures that rose in the broad strip of land separating the Euphrates from the Orontes valley and the oasis of Damascus, a kind of border line, the object of frequent and long disputes between Syrians and the kings of Calach and Nineveh. Nor was its circulation confined within these landmarks; seals, carpets, small pieces of furniture of every description,

¹ *Hist. of Art*, tom. ii. Figs. 95, 124, 138, 139, 265, 280, 331, 348, 399, 409, 430, 443.

² *Ibid.*, Fig. 249; tom. iii. Figs. 73, 76, 547, 552, 593.

served to diffuse it among all the peoples in touch with the markets of Mesopotamia. Imitations sprang up everywhere, and everywhere it retained something of the interpretation the plastic art of Chaldæo-Assyria had imparted to the noble forms of the king of feræ.

Along with characteristics common to all are differences due to personal temperament and the greater or less degree of skilfulness of the imitators. The workshops of Phœnicia issued countless proofs from this one type; in their hands, however, it assumed a redundancy of outline not found in the original. Their commonplace facility attenuated the accents put there by the firm, vigorous chisel of the Assyrian sculptor. These accents the Hittite artist did his best to preserve; but his lack of training caused him to exaggerate them. Tradition of this somewhat vulgar make is very apparent in the Phrygian lions. In order to bring out this resemblance, it will be enough to call attention to one characteristic detail, namely, the expedient resorted to by the stone-cutter to mark the shoulder-joint and the salience of the muscles. Here and there they are indicated on the limb by a raised line, oval shaped, instanced in a stela at Merash,¹ the Kalaba lion near Ancyra,² and the colossal lion which formed the external decoration of one of the finest tombs of the Ayazeen necropolis (Fig. 120). Observe, also, the strokes, forming a herring-bone pattern, which in the latter work serve to show where the mane ought to be, but scarcely aim at representing it; do not they remind us of the process employed by the Eyuk sculptor to render the deep folds of skin about the face?³ Conventional treatment, dryness, and hardness of make are inherent to both, and place these works far behind Assyrian models; nevertheless, the Kalaba lion,⁴ and even the Eyuk bull, are superior to the art productions of Phrygia of the same class—they are instinct with more truth and movement than any animal figures the Phrygian necropolis has to show.

Relations in matters of taste and workmanship, resemblances of types and methods, are likewise traceable in the scanty architectural forms revealed in the frontispieces of the Phrygian tombs. One of them is distinguished by a column, whose capital, though simpler and more primitive, in some respects

¹ *Hist. of Art*, tom. iv. Fig. 282.

² *Ibid.*, Fig. 350.

³ *Ibid.*, Fig. 340.

⁴ *Ibid.*, Fig. 339.

approaches the Doric (Fig. 92). It should be compared with the pillars at Gherdek Kaiasi, in Pterium, which also belong to the category of supports sometimes called proto-Doric.¹ We have laid particular stress on the basket-shaped capital, made up of leaves, which recalls many an Egyptian capital. Are we to view it as a unique survival of a really primitive type imported to Syria and Cappadocia from distant Egypt? The conjecture is fascinating; yet the tomb is certainly not among the oldest, and more than one monument of the Roman period could be named in Asia Minor, with capital richer and more complicated, it is true, but not without analogy with the one we are considering. If the particular order is still *sub judice*, the fact remains that we find introduced here, in a variety of ways, a decorative form of special interest to us, because of the large and brilliant use Greek genius was to make of it. We allude to the Ionic volute, whose beginnings have been made the subject of such hot disputes. The volute device may, perhaps, have been applied to surfaces other than that of columns; in which case it might be recognized in the inverted curve which appears as acroterion in the vast majority of pediments (Figs. 58, 59). But elsewhere we find it again in its real function, as crowning member to columns and pilasters; an instance of which occurs in one of the best executed façades (Fig. 61), where it is lavished, and furnishes at the sides and summit of the pilasters the elements of a somewhat elaborate design. Finally, as columnar capping in a pair of tombs of later date (Fig. 90), where it is chalked in with a careless hand, the narrow tight rolls of Figs. 93 and 96, if somewhat meagre and rigid, constitute all the same a capital not devoid of elegance. We think we have made it clear, then, that the Phrygians largely utilized the volute in their decorative schemes; a motive we tracked from Mesopotamia to Syria, on to Phœnicia and Cappadocia. Its presence in Phrygia forms one more link between her art and that of the people of Anterior Asia. It may be that we also should turn to Phrygia for the secret of resemblances which it would be hard to explain, had her monuments, like those of Lydia, perished without leaving a trace. When the temples of Miletus and Ephesus were built, the Ionians had not yet penetrated into Cappadocia; they had not beheld, figured on the Pterian rocks, the columns in which we think to recognize the rude outline of

¹ *Hist. of Art*, tom. iv. Fig. 344.

the noble architectural type with which they have had the honour to link their name;¹ but their intercourse with the well-to-do peaceful agriculturists, whose kine and corn they purchased, whose cults they adopted, and to whom in return they gave their alphabet, was frequent and intimate. In Phrygia, then, carved on wood and stone, they everywhere saw the graceful involucrum, now serving to lessen the thrust put upon the supports, now as pleasing ornament to pieces of jewellery, artistic furniture, and ivories brought by overland and sea routes.² Which, among the widely different and numberless objects challenging their attention, struck their fancy most, made them intellectually richer? We know not; save that, so far as we can guess from what has been preserved in the rock-cut monuments, Phrygian architecture must have furnished more than a useful suggestion to those receptive and curious minds.

The Greeks found something more among the Phrygians than the time-honoured volute, which had long been acknowledged as among the properties of Oriental art. Phrygian architecture was neither derived from Chaldæa, where stone is unknown, nor from untimbered Cappadocia proved by the tombal façades which are modelled upon edifices inhabited by the living. It has little to say to lignite constructions, and the exclusive use of timber gave a form to the building which is markedly different from that obtained elsewhere from stone and brick. In countries where rain and snow are not rare, the framework of the wooden house ends necessarily in a sharp ridge; a roof whose double slope describes on either side of the building a gable, of which the angle may be acute or the reverse as climatic requirements or the taste of the builder shall direct. Who does not know the importance given to the pediment in Grecian temples, where slanting lines form as happy a corona to cella and porticoes as can well be imagined; yielding, moreover, ample space upon which the ingenuity of the sculptor can be exercised? Now, the pediment is no more than a sharply defined gable, bounded at the beginning of the angle by a horizontal bar, the salience of the cornice. This form we have met once only in the course of studies in which is reflected all that remains of Oriental art. Reference has already been made to the curious architectonic shape which occurs in a

¹ *Hist. of Art*, tom. iv. pp. 694, 695, Figs. 314, 321.

² *Ibid.*, tom. ii. Figs. 71, 76-80; tom. iii. Figs. 51-53.

bas-relief, representing the temple of a town in Armenia about to fall into the hands of the Assyrians.¹ It is probable that the temple in question, situate within a cold, forest-clad region, was likewise wholly built of wood; if the Ninevite artist took pains to make a faithful copy of it, this was because he had been struck by its singular aspect, altogether different from the buildings he was wont to put in his pictures. It was a whim of no consequence, one that titillated the imagination, as a remembrance of distant campaigns, but which the Assyrians had no intention of imitating; their architecture, humble and submissive throughout its career, followed implicitly the prescriptive rules and methods of Chaldæan art.

Matters were different with the populations of the west; for on the one hand they shook off the thralldom of tradition, whilst on the other hand, whenever they looked abroad in Phrygia and Lydia, they beheld types which had originated in wood, but were imitated on stone, in the face of rocks in which Phrygians and Lydians alike hollowed their tombs. If they found there forms and arrangements to their liking, adapted to their taste and needs, there was nothing to prevent their appropriating and making use of them. Hence it comes to pass that the wooden house, as it is built and lined in certain parts of Asia Minor at the present day, may have furnished some of the elements seen in the first essayals of the Greek builder. The particular notion suggested to him in this way was to put a triangular pediment over the rectangular slab of the façade—an arrangement whose principle and model he was not likely to discover anywhere among the peoples he frequented.

There is less need to insist upon a disposition met with in several tombs of the necropolis and the oldest Greek buildings. We mean to say the slope at the sides which renders the top of the bay narrower than the base (Figs. 75, 79, 92). The arrangement is not sufficiently bound up with the processes and exigences of a timber architecture to warrant its being considered as a distinct feature of Phrygian buildings, or explain its presence in other localities, as borrowed from wooden types. The same thing may be said of the meander, which plays so important a part in Phrygian ornament, and which the Greek decorator has so often introduced into his work (Figs. 48, 49, 60). The woollen textiles

¹ *Hist. of Art*, tom. ii. Fig. 190.

and embroideries manufactured by inland tribes, and which they despatched to the markets of the coast, helped, doubtless, to accustom the eye with the pattern; yet the theme is so naturally suggested by the weaver and the mat-maker, as to be found among peoples that have never had any intercourse one with the other. It is as frequent on Peruvian and Mexican vases as on those of Greece; so that the Ionians may have discovered it for themselves, as they plaited bulrushes and handled the shuttle ere Phrygionic tissues served to furnish their dwellings.

Differences bearing exclusively on details admit, then, of being explained without calling in the hypothesis of imitation or borrowings. In the same rank with the frontal shape, which we noticed for the first time when we began to visit Phrygia, should be placed a type of burial also found there, or at least in a territory occupied for a while by the Phrygians. We were careful to make tracings of the few exemplars then known. It is a type we shall meet again, both in the Lydian kingdom, where it seems to have persisted almost down to the fall of the last national dynasty, and on the other side of the Ægean, in Greece proper, where it is represented by monuments certainly older than the tomb of Alyattes. This type is the stone tumulus, sometimes protected by a casing of well-dressed units. The internal arrangement consists of a chamber of sufficient strength to shelter the corpse, and, as a rule, of a passage leading to a doorway. But the difficulty is this: these tumuli are empty and mute, and so can tell us nothing of their history, whilst the monuments in the district of Nacoleia are signed, so to speak, and approximately dated by the people who reared them. Nevertheless the Greeks, even when supreme masters of the lower valley of the Hermus, never regarded their forefathers as the creators of the tumuli which it contains; those on Sipylus they ascribed to the quasi-fabulous Tantalidæ, and they could tell the names of the kings who had reared the Lydian monuments. The sum of evidence tends to prove that the tombs with circular base are a legacy of the civilization which in this district preceded that of Hellas. The fact, moreover, that we have observed nothing like them in Egypt or Mesopotamia, Syria or Cappadocia, is another point in favour of the argument which would consider the very particular type seen in the neighbourhood of the Smyrnian bay as neither of Oriental origin nor an importation thence; but as having been introduced by Thracian tribes, which spread under

various names and occupied the whole of the north-west corner of the peninsula. Of all these nations, the Phrygian would appear to have been the first to reach a state of cohesion and a certain politico-religious importance. Hence, in the absence of positive data respecting the primitive history of these populations, it seems natural to connect the people who first set the example of so burying their dead in Asia Minor, who furnished the model of monuments such as the famous tombs at Mycenæ, with a Phrygian stock.

It may be objected that the funereal architecture of the Phrygians of the Sangarius (who, in virtue of the witness borne by history and that of the inscription, alone deserve the name) is imbued with characteristics other than those that appear on the southern slopes of Sipylus in the Tantaleis necropolis, where rock-hewn vaults are the rule and tumuli the exception. The objection was disposed of when we defined the nature of the rock, which everywhere around Nacoleia is even with the surface; but wherever it could be readily worked, it was simpler to excavate tombs than to undertake the long arduous process of building a somewhat complicated vault. Do not we find hypogea in those parts of Sipylus where soft calcareous formations rather than hard trachytic rocks obtain? The nature of the soil and a settled condition of life may have brought about rapid changes in the habits of the people under consideration.

In a minute study such as this, it was impossible to avoid taking up conjectures one by one as they presented themselves. Towards the twelfth century B.C., perhaps even earlier, Thracian clans began to appear in Asia Minor, where they would seem to have taken advantage of the clear space left by the great migratory movement, which we find recorded in Egyptian documents; when, like bees, part of the native population swarmed and dispersed themselves along the coasts of the Mediterranean. Ere long the Phrygians, one of these tribes, founded, within the region comprised between the Hermus gulf and the mouth of the river of the same name, a state that owed much of its prosperity to the strong position it had secured for itself, along with the rudiments of civil life its inhabitants had learnt in their intercourse with the cultured people of the central plateau. These still continued to send their merchandise to those seaports they had formerly visited as conquerors. On a coast where natural harbours alternate with pro-

montories, which clustering islands prolong far out into the sea, they owned perhaps the largest and safest. In conditions such as these, a race of hardy mariners soon sprang up, who spread in the Archipelago, perhaps even on the coasts of continental Greece, along with the home produce of the rich Hermus valley, the raw material brought by caravans from Cappadocia and from farther still, to the markets of the seaboard. It is but an hypothesis that we offer, but an hypothesis apparently confirmed, and on the one hand by traditions connecting the Tantalidæ with Peloponnesus, on the other by truly curious analogies observable between certain very antique monuments found within the Argolid and those of Phrygia.

When or what the causes that wrought the downfall of the state on Sipylus, it is impossible to say. Its pristine importance, due at the outset to its situation as a natural bulwark, was already lost during historical times; and it became little more than a store-room for the memory, a holy mount. Following on the foundation of the Greek colonies, all movement and bustle had migrated to the lowlands and the narrow strips girding the sea. But the newcomers, the Æolians of Magnesia and of Smyrna, as they settled, some to the north, and others to the south of Sipylus, learnt of their predecessors traditions which told of the wealth and power of the ancient rulers; their glowing fancy, exercising itself on this theme, drew forth the myths of Tantalus, Pelops, and Niobe. In the same frame of mind, they adopted the cults they had found established in the country, and became fervent worshippers of the Phrygian Cybele; and whilst they raised her new temples, they continued to surround with pious reverence her old simulacra and the sanctuaries that were one with the holy mount. Thus the old state of Phrygia outlived itself in the impress it left in the soil and the religion it bequeathed to its heirs. But towards the tenth or ninth centuries B.C. the Phrygians of the Lower Hermus ceased to exist as a nation; for the tribes that go by that name in the epos are grouped around the head-springs of the Sangarius; they still try to extend eastward, and this brings them into conflict with the Amazons, that is to say, the warlike populations of Cappadocia. The various stages in the onward march of the Phrygians, starting from the shores of the Ægean and Propontis on to the Halys, may be guessed from the monuments themselves. Thus the tomb at Delikli Tach, situate in the Rhyndacus basin, looks older than any of the funereal monuments in the necropoles

around Nacoleia. The decorative scheme is simpler ; and, a still surer criterion, the signs by which it is accompanied are older than any alphabetical writing. The Greek epos does not know the Gordioses and the Midases ; when it was composed the names of the founders of the Phrygian power had not yet re-echoed in the Ionian and Æolian cities ; hence we think we may assume that the Phrygians did not constitute themselves into a political body, under that dynasty, before the eighth century B.C. To organize themselves into a well-ordered state may well have taken in a hundred years, during which they developed the resources of the country, opened up continuous relations with their eastern neighbours, the Cappadocians, on the one side, and the Greek-speaking populations of the western coast on the other. Besides, if we are not mistaken in refusing to seek a tomb behind the façade upon which the name of Midas may be read, it will give us one more reason for putting a pretty late date upon this considerable work, which was not undertaken the day after the death of the personage. The notion must have come much later, when the memory of the ancestor was productive of successes and benefits to his descendants, when the first Midas, magnified by the legend that already attached to his name, was nothing more for the new generations than the founder of the monarchy, the glorious father of a whole race of kings, an eponymous hero, to whom divine honours were rendered.

Consequently, it is towards the end of the eighth or the beginning of the seventh century B.C. that we would place the Midas monument and the more important tombs surrounding it, characterised by forms imitated from carpentry work, designs borrowed from tapestry, and, above all, the use of an alphabet derived from the Phœnician syllabary. We feel greater embarrassment in trying to assign a date to another group of monuments, those frontispieces of the Ayazeen necropolis, in which are seen true bas-reliefs, figures of men and lions.

Are these façades older or more recent than such exemplars as exhibit a wholly geometrical decoration ? M. Ramsay is inclined to think them more ancient. He finds in them types taken from Cappadocia, and resemblances of make to which we referred a little way back. In his estimation, real Phrygian art started into being later, when the ornamentist, shaking off the yoke in which alien traditions had held him a prisoner so long a time, set himself to

reproduce on stone all the shapes that made up the wooden house in which he lived, together with the patterns the women around him worked in the loom. If his decorative scheme is neither rich nor varied, it has yet the merit of being a faithful portraiture of the homely scenes in which it arose, and of having been kept within the limits imposed upon it by the material at hand. If it cannot be denied that the period covered by the frontispieces of the Midas necropolis is, in some respects, much the most interesting for the historian, it does not help us to understand how so simple, one might almost say so poor an ornamentation, can have succeeded one in which the living form and its potential diversity held so large a place. Art, like poetry, is progressive, and does not move from the complex to the simple, but follows an inverse course. It is possible that the clumsy pictures on the flanks of the colossal Kumbet ram, those modelled about the Yapuldak tomb by so unskilful a hand as to render it almost impossible to guess the kind of animal they stand for, as well as the rough-drawn images of Cybele seen near the tombs and sanctuaries of the plateau, preceded what may be termed the classic age of Phrygian art; but the whole group of the Ayazeen necropolis bespeaks a later epoch. The architecture is more complicated and of quite a different nature. Nothing in it betrays imitation of a timber construction; neither the columns with their varied capitals, nor the membering of mouldings with their elaborate profiles and wealth of subjects, nor the general arrangement in which the curved forms of the portico mingle with combinations of straight lines, which elsewhere cover the whole field. At the same time sculpture, properly so called, has assumed an importance it had not in the other series of monuments. Griffins and winged sphinxes abound; gigantic lions are set to watch at the threshold of sanctuaries and tombs, whilst others, of smaller calibre, are seen in pairs within the tympana of frontals. Nor is this all; the human form looks out of at least two of the better class of tombs, and furnishes the theme of a large bas-relief belonging to that fine hypogeum, the destruction of which is so much to be regretted. M. Ramsay's patient labour among these fragments, in the course of which he succeeded in turning about and uncovering nearly all those that originally decorated the main wall, has caused him to abandon the hypothesis he had at first taken up. There is nothing in it to recall Capadocian

art, either in the theme, workmanship, or accessories ; in order to find some analogy thereto we must address ourselves to the archaic work of Greece, and especially ancient vase-painting. The figures have no longer the highly conventional posture which the bas-reliefs of Pterium, and those of other localities allied to the same school, have familiarized us with ; the arms are detached from the body.

Accessories show quite as notable a change. Thus the shield is circular, the breast-plate composed of metal pieces, and the helmet has little resemblance to the Hittite cap, but is a real covering and protection for the head ; as to the huge crest crowning it, its explanation and appellative are to be sought in Homer. We have observed nothing like it either in Assyria or in the long series of rock-cut sculptures of Asia Minor, those representing the primal civilization of her inhabitants. The panoply of the two warriors who run their spears in the Gorgon's head, on the façade of a Phrygian vault, is that of the Greek hoplite, those Carian and Ionian mercenaries whose "scaly" armour terrified the populations of Syria and Egypt, when, towards the middle of the seventh century B.C., they appeared on their borders and took part in their quarrels.

The bas-relief of the Broken Tomb does not even go so far back. It plainly shows that the sculptor who modelled it had been, in some way or other, under the influence of Hellenic art. Now, to find, in Greece, figures on marble or the body of vases drawn, as these, with so remarkable a sureness of hand, we must fain descend to the latter half of the sixth century B.C. We should, therefore, incline to date the execution of both vault and sculpture somewhere about that time—a date that will, perhaps, be questioned by drawing attention to the make of the lion. The latter is much more archaic than the two heroic lance-bearers,¹ and originates, as the other colossal figures encountered in this canton, from a type created by the sculptors of Mesopotamia ; this type, when transplanted in Syria and Cappadocia, assumed a very peculiar and heavy aspect, due to sheer massiveness. If the attitude is different, the general appearance of the figure is pretty near the same as in Pterium, and the rendering of certain details is identical. Is this to be taken as a proof that the inner and external decora-

¹ With regard to the apparent anomaly, due to imperfect technique, between the workmanship of the lion and the human figures, *vide* p. 172 and note ³.

tion was undertaken at two different times—say, at an interval of a hundred years? There is no need for such an hypothesis. The monument, with its more complicated arrangement than any other exemplar of the Phrygian necropolis, is the outcome of a single effort, and the apparent anomaly is readily explained. As the lions were mere decorative figures, the work of carving them was left to craftsmen who repeated a traditional type, numerous instances of which already existed in the necropolis. This does not apply to the bas-relief in the cemetery, which is unique of its kind. The man for whom it was carved, a petty local prince under the jurisdiction of the Persian satrap of Daskylion, wished to have something out of the common, when he ordered the image of genii, guardians of the tomb, to be set at the entrance of the burial place which was to receive his mortal remains. To this end he called in a sculptor whose training had brought him in touch with the Greek world of the Ionian coast, where art was even then making such prodigious strides towards perfection.

The Broken Tomb, then, belongs to the opening of the second period of the development of Phrygian art. General arrangement and selection of forms, the whole architectural scheme, still bears the stamp of early habits and local taste, whilst the ornament is entirely borrowed from that old repertory of devices and symbols which had satisfied older generations. But in the frontispiece of the funereal chamber we have a sculptured page dictated by a new spirit, written by a different hand.

The same analytical test, applied to the neighbouring hypogeia, would result in the same remarks; we should see that the primitive forms and national subjects have undergone gradual modification by contact with Hellenic art; and, as in the Kumbet tomb (Fig. 84), the theme is still thoroughly Asiatic, thoroughly Phrygian if preferred, whilst the manipulation of bas-reliefs and mouldings testifies to a more refined and elegant taste.

The Kumbet exemplar, therefore, cannot be carried back beyond the end of the fifth century, and may, after all, date from the fourth century B.C.¹ Ancient traditions, whether of general

¹ HIRSCHFELD (*Paphlagonische Felsengräber*, p. 41) does not consider the tomb older than the fourth century. He compares it with the Lycian tomb at Myra (published by TÉXIER, *Description*, tom. iii. Plate CCXXV.), in which the subject—the deadly conflict between two animals (a lion and a bull)—is strictly Oriental, whilst the architectural types belong to the Ionic order, of universal usage in the peninsula during the two last centuries of the pagan era.

adjustment or details, were discarded in the tomb of Gherdek Kaïasi; it is no more than a Greek monument of the decadence, one we might as readily expect to see elsewhere as in Phrygia (Fig. 91), and in all likelihood is coeval with the Seleucidæ, mayhap the Roman proconsuls of Asia. On looking at it, we feel that when the artist designed it all meaning and tradition of rock-cut architecture were already forgotten; the slender supports of the façade, the wide intercolumnation which separates them, ill agree with the massiveness of the native rock in which the sepulchre was hollowed. Taken as a whole, it falls short of the air of strength and solidity which a rock-cut structure ought to possess.

The fact of Oriental types having died exceedingly hard about the tombs in the vicinity of Nacoleia is to be explained by the memories and associations which attached to the canton. Packed away in a hilly well-timbered region, untraversed by the military or commercial highways, it was in the nature of things that it should have lain forgotten by Greek and Latin writers—by those, at least, who have come down to us. Mention of it may have been made in the pages of those monographs entitled *Φρυγικὰ* (*Histories and Descriptions of Phrygia*), but such works are lost. Fortunately for us, the silence of texts is supplemented by monuments both varied and numerous; they permit us to guess that the situation of this district did much to mould the character of the real Phrygian people, those of the Gordioses and Midases, as well as the light in which they were held by their Hellenized descendants, who for centuries were wont to engrave on their coins the effigy of their ancestor Midas (see tailpiece, end of chapter), and who, in the age of the Antonines, would not have readily believed in the efficacy of the formulas incised on their funereal stelas, had not letters of their ancient and, doubtless, obsolete language been interpolated with them. The tribes that fought the battles around the head-springs of the Sangarius, the echo of which reached Homer, tribes that secured to their descendants possession of part of the plateau of Asia Minor, had here their first religious and political centre. Under the protecting shadow of rock-hewn strongholds, they gathered themselves around sanctuaries, consecrated, mayhap, by the former owners of the soil, whose religion was adopted and continued by the new-comers. As the spring came round, these sylvan scenes would resound with the voice of young life; lambs, kine and colts that frolicked under

the vault of undying pines in sheer wantonness of youthful spirits. Here twice a year were celebrated the mysteries of Cybele and Atys, the king and the heads of the various clans taking part in the ceremonies. Tents and temporary booths were set up on the greensward, whilst prince and nobles, during the festivities, occupied roomy wooden houses planted on artificial esplanades, of which we found traces on many a point; "konaks," they would be called at the present day, very like the kiosk of the old Dere Bey of Kumbet (Fig. 83). There never was here a town, as we understand the term—as Apamæ and Celenæ, Pessinus and Ancyra, for example. Real Phrygian cities, of which many are still important centres, were built on better chosen sites, lending themselves more readily to supply the wants of an agglomerated population all the year round. In this district water fails during the hot summer months, but with the autumnal rains of October silvery rills reappear, when along their banks cattle find an abundance of coarse tall grass to the end of June.¹ Picturesque rural retreats such as these seemed marked out for those *al fresco* festivities, *panegyria*, which have never been out of fashion with Eastern races, Greeks, Syrians, and Turks. With the return of each season, woods and meadows, even as the valley of the Alphæus during the Olympian games, would fill with the hum, the stir and merriment of thousands of human voices, married to the confused sound of flutes and tambourines; the multitude passing, with scarcely any transition, from frenzied joy to black despair. The cares and routine of daily life were for the time suspended or forgotten; every sense was employed in celebrating the public rites of the national gods. On such occasions visits were paid and sacrifices and libations made to the manes of ancestors who had wished their tombs to be placed under the special tutelary wing of Cybele, whose style and image appeared on these same rocks.

¹ To find a perennial spring, says Barth, one must needs go as far as the neighbourhood of Doghanlou Deresi (8 in map) and Gherdek Kaiasi (3 in map), some two hours north of the Midas monument. This is one reason which prevents us seeking there the "town of Gordios" (Γορδίου πόλις), also named Gordion, supposed to have been "the hearth (cradle) of ancient Midas," writes Plutarch (*Alexander*, xviii.); a conjecture overthrown by Arrian, who says of Gordion, "It is found on the river Sangarius" (*Ana.*, i. 29), a situation which does not by any means fit the site we have called "Midas city." Arrian's testimony, especially upon matters relating to Asia Minor, is generally correct.

The main cause why the monuments under notice were saved from destruction is to be accounted for in the fact that there never was here a great urban population. The contempt and discredit that fell upon the old beliefs when the antique world fell to pieces caused sites, formerly the objects of frequent pilgrimages, to be neglected and forgotten by all save tillers and woodmen. Thus it came to pass that until the beginning of the present century, when these monuments were discovered by travellers, there had been nothing to disturb the dust gathered around what may be called the museum of Phrygian art. Had these works perished, like others of the same kind and style that doubtless once peopled the necropolis and cities of Phrygia, there would have been one more lacuna, hard to fill in the history of civilization and of the plastic arts. We should have been unable to form a correct estimate of the influence exercised upon the Greeks by certain nations of Asia Minor, both as middlemen and creators of not a few architectonic and ornamental forms. Nor is this the only title the relics of Phrygian art offer to the lively interest of the observer; what adds to their importance is the fact that here, perhaps, are to be found the oldest traces of the influence Greece (from having at first received on all sides) began to exercise over nations who had been her first instructors. This she did with characteristic vigour and power.

The first symptoms of this singular phenomenon, this returning wave, are manifested on the monuments of Phrygia. The Greeks, in the opening years of the seventh century B.C., gave their alphabet to an independent community settled far enough from the shores of the Ægean. This was ere long followed by Grecian architecture and Grecian sculpture. At this school, Phrygian artists learnt the secret of imparting just proportions and freedom of movement to the human form; they accustomed themselves to enclose within mouldings of greater variety and refinement symbols dear to their ancestors, when internally and externally a gradual change spread over their façades.

Thus, on the soil of this vast mountainous peninsula, where the sons of Hellas owned but a narrow strip fringing the sea, new forms, new ideas stole in on every hand, which traffic and example helped further to disseminate long before any Greek captain had scaled, with his army, the terraced hills in advance of the inland

plateaux. The battles of the Granicus, Issus, and Arbela were no doubt of great service in opening more widely existing routes, breaking down the last barriers; but military action alone would have been powerless to effect a radical and lasting change in the condition of the world, had not a long period of tranquillity prepared the way, during which a propaganda, pacific and fruitful, was carried on, which contributed not a little in bringing about the final result, the definitive triumph of Hellenic genius, and the subjugation of the whole East to the commanding superiority of Greek civilization.



LYDIA AND CARIA.

CHAPTER I.

THE LYDIANS, THEIR COUNTRY, HISTORY, AND RELIGION.

THE Lydia of Greek historians and geographers was comprised within the small basin of the Cayster, the lower and middle valley of the Hermus, and extended as far as the right bank of the Mæander, which served as line of delimitation between it and Caria. "Homer," says Strabo, "was unacquainted with the Lydians."¹ The country subsequently so named is styled by him "pleasant Mæonia."² Should the two names be taken to designate two different peoples who succeeded each in the country, or were they applied to twin groups of the same race, the last one of which finally obtained the upper hand? There is a greater degree of probability for the latter hypothesis; since the Lydian nation, as is well known, was made up of several tribes. The appellative Lydian would seem to have been borne by the tribe settled around the middle Hermus, and to have gradually extended to the whole people. This was mainly due to the foundation of Sardes, whose commanding situation would of itself secure to its owners a marked ascendancy over the other clans. The ancients were fully conscious of the comparatively recent period of that city and its fortress. This they expressed after their own fashion, when they said that Sardes had risen after the Trojan war.³

From the Greek lyric poets of the seventh and sixth centuries, we get the first glimpse of Lydia and the Lydians. As to the little that is known of their history, we are mostly indebted for it

¹ Strabo, XII. viii. 3; XIII. iv. 5.

² HOMER, *Iliad*, iii. 401; xviii. 291. The name of Mæonia was not wholly wiped out; under Roman domination it was still applied to a city and district north of Philadelphia, between it and Mount Tmolus.

³ Strabo, XII. iv. 5.

to Herodotus and Xanthus of Lydia.¹ The latter was an Hellenicized Lydian, who wrote in the early part of the fifth century. His book is unfortunately lost ; and it may be questioned whether the fragments that have been preserved by Strabo, notably Nicholas of Damascus, really belong to the old logographer, and not rather to a far less reliable writer, one Dionysius Skythobrachion, who seems to have compiled a history of Lydia during the Alexandrian age, which he published under the venerable name of Xanthus.² Such a suspicion, in a certain measure, throws discredit on the testimony of Xanthus, who on many points is at variance with Herodotus ; nevertheless there is a tendency to believe that, though the Alexandrian rhetorician may have embellished and added many stories of his own to the work of his predecessor,³ whose great name he pirated, he yet, on the whole, closely followed him. From the citations we infer that he was a man given to the observation of nature, one, too, who had lived in the country ; for he is circumstantial and precise in his remarks respecting the natural phenomena to which Lydia owes its peculiar configuration ; nor is he less well informed as to its antiquities. Such things would have had no interest for the pedantic bookworms of Pergamus and Alexandria. It is possible that had the work of Xanthus been preserved in its entirety and in the language in which it was originally written, its testimony, in matters pertaining to Lydia, would be found of even greater weight than that of Herodotus himself. He was familiar with the native language, which had not yet fallen into desuetude through the diffusion of the Greek tongue ; he was thus able to consult the archives of the country, which were of no small importance for the work in hand.⁴ The main thread of Herodotus's narrative is made

¹ BERGK, *Poetae Lyrici Græci*, 3rd ed. ; Sappho, Frag. 85 ; Anacreon, Frag. 18 ; Hipponax, Frag. 15 ; Xenophanes, Fr. 3, etc.

² See notice upon Xanthus and the fragments preserved in tom. i., *Fragmenta historicorum græcorum*, Ch. and Th. Müller.

³ Nicholas of Damascus, a famous rhetorician of the Augustan age, probably borrowed the substance of the fourth and sixth book of his *Universal History*, dealing with Lydia, from Dionysius Skythobrachion's work, rewritten and arranged to suit the taste of the day. Lengthy fragments exist of these two books, notably the second (*Fr. Hist. Græc.*, tom. iii.) ; if mixed up with much that is purely romantic and fantastical, there are yet curious data which would seem to belong to Xanthus himself.

⁴ Nicholas of Damascus (Frag. 49, 21) says of a certain Spermios, who would seem to have occupied the throne for the space of two years : ἐν τοῖς βασιλείοις οὐκ ἀναγράφεται. As to the time when Xanthus lived, see Letronne's notice (*Œuvres choisies*, tom. i. pp. 203-206, 8vo, 1883, Leroux).

up of gossiping stories current in the Greek cities of the seaboard; more particularly hearsay evidence he had picked up at Delphi, where the stupendous gifts the shrine had received from the last kings of Lydia had served to keep green the memory of their names. It may be easily guessed that in such an atmosphere facts would necessarily undergo notable change and disfigurement, so as to enhance the importance of the oracle and prove its infallibility.

This is not the place for endeavouring to reconcile the conflicting evidence found in Herodotus with that ascribed to Xanthus, or to enter into the very obscure question as to the chronological order of the Lydian kings. Of the history under notice we require no more than what will help to understand the monuments. Herodotus reckoned three dynasties as having succeeded each other in Lydia: the Atyadæ, Heraclidæ, and Mermnadæ.¹ The first is purely fabulous; born of the vanity of the Lydians, and of their desire to possess a past no less remote than their eastern neighbours. We feel on scarcely more solid ground with the Heraclidæ, to whom Herodotus assigns five hundred years duration and twenty-two princes, since it is self-evident that a mere string of names, wholly bare of facts, could only have been obtained by artificial means; exception may, perhaps, be made for the two or three last reigns. With the Mermnadæ history may be said to begin.

The exact date of the advent of Gyges, the founder of this dynasty, is not fixed with any degree of certainty. What seems pretty sure is that Greek chronographers put it too far back; on the basis of Assyrian documents it is now moved on to the seventh century B.C.¹ On the other hand, the date of the overthrow of Cræsus and the taking of Sardes, his capital, by the Persians in 546 B.C. may be relied upon. It enables us to compute the reign of the Mermnadæ at a little over a hundred and fifty years, during which they raised the Lydians, who up to that time had been of no account in the world, to the first rank in the peninsula, and masters of more than half of it. If Lydia ever produced original works, we may affirm beforehand that they belonged to this period,

¹ Herodotus, i. 7.

² Gelzer, who has studied with care the early period of Lydian history, gives the following dates as the result of his calculations. According to him, Gyges reigned from 687 to 653; his son Ardys from 652 to 616.

the only one when her people were united enough, powerful and rich enough, to have a culture and an art of their own.

The monuments in question are unfortunately very few, and in the number there is not a single inscription, or a text, or even half a dozen letters, which would give us the clue to the Lydian language, or, at any rate, its alphabet.¹ Consequently we have not, as in Phrygia, the resource of turning to the language in order to extract therefrom some little light upon the origin and the ethnical affinities of the people. All we can do is to take down the testimony of the ancients, without the possibility of checking it.

Herodotus represents the Mysians as a branch of the Lydian stock, from which it had separated at some time or other²—an assertion confirmed by Xanthus, since he gives formal expression to the effect that the spoken dialect of the Mysians held a middle course between that of the Lydians and the Phrygians.³ Linguistic research has established in full the opinion of the two historians. Thus of the few Lydian words which lexicographers have rescued from oblivion in their glossary, most are susceptible of being explained by roots common to Sanscrit and cognate Indo-European languages.⁴ Some of these words are found both in the Lydian and Carian, others in the Lydian and Phrygian idioms.

Still further proofs may be adduced, on the authority of Herodotus, in support of the near kinship between Mysians, Lydians, and Carians, since he affirms that they looked upon themselves as of one family, and that, in virtue of this consanguinity, the temple

¹ Unknown characters have been discovered, which, had they been submitted to a competent authority, might have turned out to be Lydian inscriptions; for M. G. Hirschfeld thus wrote in 1870, "Whilst the works for the construction of the railway were proceeding, huge blocks of stone were dug up at Sardes, on which appeared unknown characters, resembling, it is said, cuneiform characters. Further information is to follow" (*Bulletin de l'Institut de correspondance archéologique*, 1873, p. 225). The promise thus made was never fulfilled. One is also tempted to see a Lydian text in the monument uncovered by Fontrier at Ak Hissar, ancient Thyatira (S. REINACH, "Chron. d'Orient," *Revue arché.*, 3^e série, 1886, tom. vii. p. 165). An impression of it was shown to Professor Sayce, but he confined himself to the statement "that, whatever the characters might be, they were not Hittite." During Professor Sayce's excursion in Lydia, he was informed of the existence of a rock-cut inscription in cuneiform characters (?) to be seen in a secluded corner of Mount Tmolus (*Journal Hell. Studies*, 1880, p. 88).

² Herodotus, vii. 74; οὗτοι (the Mysians) δέ εἰσι Λυδῶν ἀποικοί.

³ Xanthus, Fr. 8. Another native writer, Menecrates, furnishes a like intelligence (Strabo, VII. ii. 3).

⁴ PAUL DE LAGARDE, *Gesammelte Abhandlungen*, pp. 270-276.

of Carian Zeus, at Mylasa, which no stranger was allowed to enter, stood open to Lydians and Mysians.¹ If, setting aside local cults, which are very imperfectly known, we consider solely the broader features of the creeds which obtained in the west of the peninsula, we shall be able to say that the religion of the Phrygians and Lydians was identical. The most important temples of Lydia were consecrated, as in Phrygia, to the great goddess who personified the creative power of Nature—she whom the Asiatic Greeks (heirs and pupils of the nations they had found settled on the soil) worshipped, now under the name of Cybele, as at Smyrna, and now under that of Artemis, as at Ephesus. Atys, the inseparable companion of Cybele and the lunar god, Men, were honoured as much in Lydia as in Phrygia. Lydian and Phrygian myths represented the hero Mânes as the founder of their respective national dynasty.² Then, too, the basis of religious belief and the character of public worship of either country are very similar, save that myths in Lydia have assumed a very peculiar form and complexion. Such would be that out of which the Greeks spun the tale of Heracles and Omphales.

Let it be demonstrated, then, that whether the Lydians originally came from Thracia, or entered Asia by another route, they none the less belonged, as all their neighbours, to the Aryan family. If this was for a long time a moot question, if the Lydians were considered as Semites, it was on the strength of a verse in Genesis;³ but this curious chapter (tenth) has no longer the authoritative weight it once had, even in the eyes of orthodox commentators.⁴ Besides, it is now generally acknowledged that the ethnographic, or rather ethnogenetic, classification which the author of the genealogies strove to establish corresponds, at least in its general outlines, with the geographical table of the distribution of the human families over the earth's surface. Thus, to the north and south are people descended from Japhet; the sons of Ham hold Southern Syria

¹ Herodotus, i. 171.

² PLUTARCH, *Isis and Osiris*, 24; Herodotus, i. 94, iv. 45; DENYS OF HALICARNASSUS, *Roman Antiquities*, i. 27. Mânes has been compared with the Indian Manû and the Teutonic Mannus. It would be more risky, perhaps, trying to do the same for the Cretan Minos.

³ Gen. x. 22: "The children of Shem; Elam, Asshur, Arphaxad, Lud, and Aram."

⁴ LENORMANT, *Les Origines de l'histoire d'après la Bible et les traditions des peuples orientaux*, tom. ii. p. 324.

and Africa, and between the two stands the family of Shem, to which the sacred writer belonged. The nations of each group, represented by these various names, are ranged as near as possible as they would be on the map. One of two things may have happened: either the scribe of these tables put the Lydians between Chaldæa (Arphaxad) and Syria (Aram), or the appellative may denote a tribe of Mesopotamia unknown to us under that name; or it may have been altered through a copyist's error.¹

Whichever conjecture be adopted, the reasons that tell in favour of the Lydians being nearly related to the nations who inhabited the west of the peninsula, between the Halys and the Ægean, are far too weighty to be upset by an isolated doubtful and obscure passage. On the other hand, it is not to be denied that Semitic culture would seem to have had a deeper and more lasting hold on them, than on any of the tribes settled within the northern edge of the central plateau between the Halys and the Euxine; in other words, on Phrygians, Bithynians, and Mysians. Traditions, language, and public ceremonies all testify to the relationship and interaction existing between these various populations.

The national legends allied Ninus, the head of the second Lydian dynasty, to Chaldæa and Assyria, when they made him the son of Belus.² All reminiscence of Eastern conquerors had been blotted out by the later splendour and magnificence of the victories and the power of the Sargonides and of Nebuchadnezzar. Nineveh and Babylon had caused Carchemish to be forgotten; nevertheless, some faint trace, it would seem, had lingered in the memory of the Lydians, as to the relations which had once existed between their ancestors, not with the great military states of Mesopotamia, but with the masters of Syria. Lydian princes, it was said—Mopsos, Ascalos—had carried their arms as far as Ascalon.³ Similar tales, if they contain a residuum of truth, can but allude to a share taken long ago in the wars the Khetas had waged against Egypt. However closely allied the Lydians may have been with the Mysians and Phrygians does not preclude the possibility that they were the first to reach the peninsula, early enough to join in the ambitious

¹ This last notion is the one adopted by M. JULES HALÉVY (*Recherches Bibliques*, p. 165). It is for Hebrew scholars to criticise the correction proposed by him.

² Herodotus, i. 7.

³ Xanthus, Fr. ii. 23.

designs and lust after plunder of the "league of the seafaring nations," which had caused Pharaoh to tremble on his throne.¹

These distant expeditions and advanced posts to the southward were, after all, but incidents of little moment in the life of these populations; the two sets of influences brought about by conquest and commerce were far more reaching in their consequences. It will not have been forgotten that the Syro-Cappadocians at one time extended their dominion as far as the Lower Hermus, and here, in the vicinity of Smyrna and Magnesia, are found signs of their peculiar writing and types created by their art. Consequently the origin of the Heraclidæ should be sought, not in the valley of the Euphrates, but among the primitive owners of the peninsula, as likely to furnish the explanation to the names of Belus, Bel, and Ninus, which latter headed the list of that dynasty. If we know nothing of that remote age, more than one indication permits us to guess the effect of the continuous relations the Lydians entertained with that Syrian nation who, holding both sides of the Taurus, ended by gaining a firm foothold on the middle Halys, in the very heart of Cappadocia. It is possible that the Phrygian and Lydian Atys may have originated with Atar, Ates, who appears as a local deity in Northern Syria.² The divine name Ate is compounded with several names of the sovereigns of Lydia—Sandyattes, Alyattes; and its place as a suffix is in accordance with the formation of theophore names in the idioms of the western Semites.³

A conspicuous figure in the Lydian legends is that of Iardanos, the father of Omphalos, a name which vividly recalls the principal stream of Palestine, Jordan, *the river*.⁴ Instances such as these deserved to be noticed, inasmuch as they suggest conclusions confirmed in full by all we know of Lydian religions. Purely

¹ M. Maspero, however, thinks that Chabas erred when he recognized the Mæonians in the list of the "sea-people;" in his opinion the group of hieroglyphs, the object of the discussion, yield "Iliouna," not Maouna. On the other hand, he is inclined to see, in the oft-cited name of Shardana, the ethnic encountered among the Greeks (who had no *she*) in the name of Sardes city.

² Upon the god Ate and the texts in which he figures as one of the elements of a made-up name, see ED. MEYER, *Ueber einige semitische Goetter*. iii. (*Zeitschrift der Deutschen Morgenlaendischen Gesellschaft*, xxxi. pp. 731, 732).

Similar names would be formed like Hebrew proper names ending in *el*—Joel, Abimael; or an abridged form of Jahveh—Adonijah, Elijah.

⁴ The correspondence is due to ED. MEYER, *Geschichte des Alterthums*, tom. i. § 257.

Semitic were those sacred prostitutions which Herodotus notices with astonishment as existing among the Lydians,¹ as well as in Cyprus, whither they had been imported from the same source.² The stamp of Syrian cults is even more distinct in the myth of Atys, slain by a wild boar raised against him by Zeus, wroth at the divine honours paid to the former ;³ in which we at once recognize the great Byblos myth, that of Adonis-Tamuz. Again, in the story told by Herodotus of Atys, the eldest son of Cræsus, who is killed by Adrates during a boar's hunt, one is tempted to see a later and somewhat modified form of the same myth.⁴ The theme is invariably that of a fair youth, tenderly beloved, who falls a victim to an impure, loathsome monster ; stirred by the catastrophe which had engulfed the powerful family of the Mermnadæ, popular fancy demanded of fable the elements it spun around the tragic event, so as to deepen the interest attaching to a great empire overthrown, together with the royal family which had created it.

When did the warlike people whose power was supreme in Cappadocia cease to overrun as conquerors the basins of rivers that descend towards the Ægean, or, at any rate, maintain their ascendancy, based upon superiority of arms and civilization ? When did the Lydians constitute themselves into a well-ordered independent state ? These are questions which it is hard to answer. The Assyrian horizon, down to the reign of Asur-nat-sirpal, was bounded in this direction by the Amanus and the Taurus range. As to the Greeks of the coast, they at the outset lived with their eyes fixed upon the sea by which they communicated with their brethren ; not until ambitious princes arose, who began to threaten and molest them in their rear, did they turn their faces in that direction. From that hour, self-defence compelled them to interest themselves in the events that were taking place in Lydia, the rebound of which would ere long be felt on the littoral. It caused them to acquaint themselves with the names, deeds, and character of the kings of Sardes. Henceforward, Western Asia has a history of its own ; and albeit, down to the Persian conquest, it is still mixed up with many fables, it contains, none the less, a

¹ Herodotus, i. 93, 94.

² *Ibid.*, 199.

³ This was the rendering of the myth as presented by the poet Hermesianax, a native of Colophon, familiar, therefore, with the legends of Lydia.

⁴ *Ibid.*, 36-46.

certain number of well-established facts and dates, which latter, within a few years, may be fixed with certainty.

The glimpses we catch in the preceding period are to the effect that when the Phrygians, towards the tenth century B.C., established themselves on the central plateau, the Syrian tribes were obliged to fall back and fortify themselves beyond the Halys; the newcomers then formed around the head-springs of the Sangarius and the Mæander a thick curtain of sedentary populations, behind which the Lydians were able to constitute themselves into a nation. When the mist that had shrouded them for a long time began to disperse, they appear as a feudal state, in the reign of the last Heraclides; their principal districts are presided over by those subordinate dynasties, whose bloody quarrels and rebellions greatly curtail the power vested in the nominal sovereigns enthroned at Sardes. The title of "king's companion"¹ made of the nobleman possessing it a kind of grand vizier, the keeper of the double-edged axe, symbolic of supreme authority, and therefore the real head of the state. Two families—both allied to the reigning family—the Tylonidæ and, above all, the Mermadæ, contended for so exalted a situation. Now, it happened that the mayor of the palace of the last Heraclid was a Mermnad of the name of Gyges, who, to possess himself of the throne, murdered the king, variously called Sandyattes and Candaul by Xanthus and Herodotus. A long civil war followed, and in the end the usurper saw his authority universally acknowledged.² This revolution, the first well-known event in the history of Lydia, was big with meaning for the Asiatic Greeks, and would seem to have made a profound impression upon them. Hence it is that the name and individuality of Gyges speedily passed into the domain of fiction. Herodotus and Plato make him the hero of an extravagant tale, in which foolish king Candaul, the owner of a magic ring which renders its possessor invisible, is brought to an untimely end by his indiscreet vanity.³ Though no less strange and fabulous, Xanthus's version lacks the piquancy and happy turn of phrase, the

¹ This may be gathered from a passage where Plutarch (*Greek Questions*, 45) alludes to the king's companion and axe-bearer as symbolic of supreme power. Cf. Nicholas, Fr. 49, i. 30.

² The data to be found in Nicholas of Damascus, Fr. 49, relating to the change of dynasty, has enabled Gelzer to reconstitute with a great degree of probability their sequence up to the enthronement of Gyges.

³ Herodotus, i. 8-13; PLATO, *Republic*, ii. 3.

cunning art, of the above writers.¹ The astonishment and awe aroused in the Ionian cities were deep and profound at the sight of a people concentrating themselves under the command of an energetic and gallant captain, for the avowed purpose of attacking their neighbours and moving back their frontiers in every direction; who, whilst their hands were full in quelling internal disturbances, had allowed the Greeks to spread along the coast, ascend the course of the rivers up to a certain distance, and occupy the fertile stretches around Magnesia. As soon as they became conscious of their strength, they regretted having given up to another people so many fertile deltas, so many fine harbours hollowed beneath high promontories, when the desire to have an outlook towards the sea became too strong to be resisted. Lydia is one of the most favoured, the most fertile regions of the peninsula. The winter is milder and the summer less dry than on the central plateau, and its situation near the sea also causes more rainfall. The vine, olive, and fig tree prosper on the lower hills; the slopes of Tmolus and other mountains are, and above all were, covered with forests of pine, oak, and beech. These slopes now are brown and bare, and have never recovered from the wanton neglect, and worse, brought about by ages of wretchedness and misery which followed on the fall of the Roman Empire. In the plains, many of which are extensive, the soil consists of a fat ooze, left by the overflowing of streams after they have rid themselves of the pebbly mass wrenched from the flanks of the mountains, when their course becomes sluggish and peaceful, and lends itself to the purposes of irrigation, so that the land can be turned to pasture or ploughed fields at will. The best-mounted horsemen of Asia Minor were Lydians, because they had an abundance of grass.

The clemency of the heavens, the variety and plentifulness of rude creature-comforts, which an inexhaustible soil provided for man and beast, all conspired to ensure the well-being of the inhabitants; and when a lucky chance raised in their midst intelligent and energetic chieftains, what more natural than that a remarkable development, political and military, should have been the result? That which also contributed to the rapid growth and prosperity of the commonwealth was the happy choice of the site upon which was built their capital—a site easily identified, whether from indications

¹ NICHOLAS OF DAMASCUS, *Frag. Hist. Græc.*, tom. iii. pp. 384, 385.

scattered up and down in history, or the magnitude of the ruins still to be seen, or the name of Sart, which, handed down by tradition, is applied to a few huts, the sole representatives of the once great centre. The most frequented route of all those that descend from the Phrygian uplands, the "royal highway" of Herodotus,¹

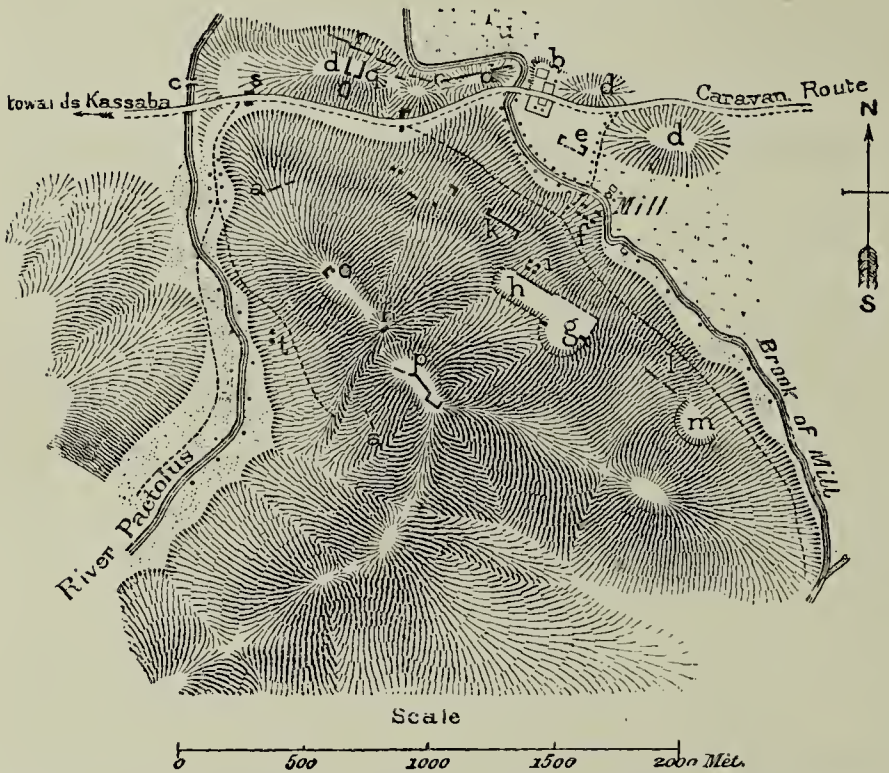

FIG. 153.—Site and ruins of Sardes. Topographical sketch. CURTIUS, *Beiträge zur Geschichte und Topographie Kleinasiens*, Plate V.²

as it emerges from the ravines of the Hermus, towards the flat level, is met, nearly opposite, by Mount Tmolus, whose highest ridge faces south and bounds the plain; whilst in the direction of the north-west it throws out a long narrow counter-fort, whose abrupt and almost vertical slopes are about five or six kilometres from the river.³ A low hill connects this spur with the mountain mass;

¹ Herodotus, v. 52.

² Legend of map: *a*, hut; *b*, coffee-house and grocer's shop; *c*, piers of ancient bridge; *d*, rubbish heaps; *e*, church (ancient gymnasium); *f*, church; *g*, theatre; *h*, stage (*stadium*); *i*, vaulted double door; *k*, ruin, Lower Empire; *l*, substructures; *m*, odeum (?); *n*, gibbet facing the Acropolis; *o*, upper citadel; *p*, advanced works of citadel; *q*, substructures of temple; *r*, supporting walls; *s*, remains of city wall; *t*, temple said to be of Cybele; *w*, bearings of tomb of Alyattes.

³ Our description is chiefly borrowed from E. CURTIUS, *Beiträge zur Geschichte und Topographie Kleinasiens: Sardes*, pp. 84-88 (*Abhandlungen* of the Berlin Academy, 1872). See also TÉXIER, *Asie Mineure*, 8vo, pp. 252, 253; STARK, *Nach dem Griechischen Orient, Reise-Studien*, 8vo, 1874; SAYCE, *Notes from Journeys in the Troad and Lydia*, pp. 86, 87 (*Hell. Studies*, 1880); J. SCHMIDT, *Aus Constantinople und Kleinasien*, pp. 150-153 (*Mittheilungen d. d. archæ. Inst. Athens*, 1881). A plan of Sardes, forming part of an unfinished and undated work, despite jerky and indifferent execution, has likewise furnished some curious documents (TRÉMAUX, *Explor. arché. en Asie Mineure*, Hachette). Useful information was also had from Gregorovius's account of a visit paid in 1882 to the ruins of Sardes, containing a brilliant sketch of the history of Lydia, and a graphic description of its physical

then the ground shoots up into a sharp ridge, the culminating point of which is two hundred metres in height (Fig. 153).¹ A deep sinking, or ravine, occurs east and west of the ridge; in the one which is all but dry in summer flows the Pactolus after rainfall, whilst the other, fed by a copious perennial spring, has enough of water to turn a mill. These waters, it would seem, were utilized in olden days by draining them into a ditch that covered the town to the northward, whence they ran to join the Pactolus, to fall together into the Hermus. The principal quarter of the city, now occupied by the bazaar, and the rendezvous of caravans, was on this side, and faced the point where the two streams met. From the bed of the torrent to the foot of the hill are spacious platforms which support the houses and structures of the town; it was an open city both in the day of the Lydian kings and the Achæmenidæ; the whole effort of the defence was directed to the citadel.² Little need was there to aid the work of nature; even now the steep rugged paths leading to the summit, once girded by a wall, are climbed with great difficulty (Fig. 154).

Rising on the site where the mountain more nearly approaches the river, the fortress commanded and watched over the adjacent country far and wide. Under its protecting shadow, each year since the advent of Gyges, as the spring came round, the Lydian cavalry assembled in the grass meadows around, and formed themselves into those squadrons that were wont to be away the whole summer on warlike expeditions. At the outset, aided by the Ionians, Gyges had seized the whole of Mysia, from the Gulf of Adramyttion to the farther bank of the Rhyndacus.³ Had not the new king, in order to strengthen his as yet tottering throne, asked for the moral support of the Delphic oracle at the beginning of his reign, and repaid it with a liberal hand?⁴ Had not he helped the

aspect ("Sardes," *Kleine Schriften zur Geschichte und Cultur*, tom. i. pp. 1-47, 18mo. Leipzig: Brockhaus, 1887).

¹ The market of Sardes extended along the two banks of Pactolus. See Herodotus, v. 101.

² This may be inferred both from Herodotus's account of the siege of Sardes by Cyrus (i. 80-84), and the attack directed against it, fifty years later, by the Athenians and Ionians (v. 100, 101). In both instances the defenders of the place gave up to the enemy the lower city, and withdrew themselves into the citadel.

³ Strabo, XIII. i. 22.

⁴ Herodotus, i. 14; Nicholas of Damascus, Fr. 49.

Milesians to found the colony of Abydos, on the Hellespont? ¹ Were not soldiers of fortune, whether Carians or Ionians, bent on adventure and plunder, sure to get both while serving under his banner? ² The good understanding was of short duration. Intercourse with the Greeks, mayhap friendly visits to their flourishing cities, roused in the breast of a prince already master of a vast territory, and the head of a brave and well-equipped

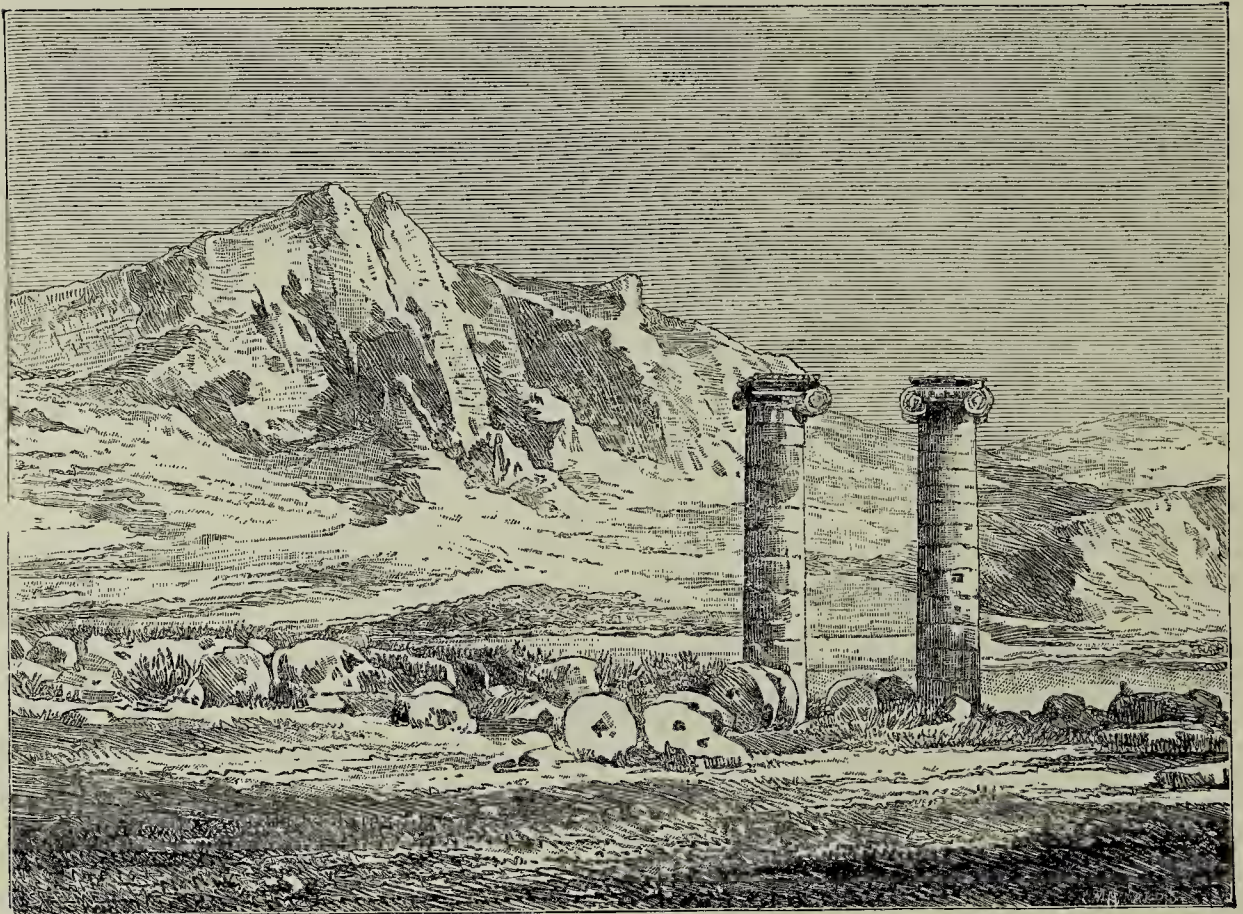

FIG. 154.—View of Acropolis at Sardes, taken from the left bank of the Pactolus, opposite the temple of Cybele. CURTIUS, *Beiträge*, Plate VI.

nation, the ambitious design of subjecting these inventive minds and energetic characters, of confiscating for his own benefit so brisk an industry and maritime commerce, along with multitudinous workshops and harbours, all their power and riches. He first attacked, but failed to carry, the fortified cities of Smyrna and Miletus; he was more successful before Colophon,³ and possession of the place gave him the control of the Cayster and cut up Ionia into two halves. Gyges was indeed defeated and slain by the Cimmerians

¹ Strabo, *loc. cit.*

² Mention is made by Herodotus (i. 77) of the mercenaries the Mermnadæ kept in their pay.

³ Herodotus, i. 15, 22, 26.

in 650 B.C. ; but neither his death nor his defeat were fraught with grave consequences. The invaders, after having ravaged the peninsula, retired as suddenly as they had come ; and, once the storm was over, the Lydian monarchy resumed the work—momentarily interrupted—at the point where it had been left. Ionia had suffered quite as much as Lydia ; but the latter, with Ardys and his three successors, Sadyattes, Alyattes, and Crœsus, was not only able to reconstitute her military power, but to harass the Greek maritime cities with repeated and frequent attacks for the space of a hundred years. Jealousy of one another prevented these small communities banding together for the purpose of opposing a stout resistance against the common foe ; singly they could not levy a sufficient number of troops to oppose with any hope of success the cavalry squadrons which the Lydian princes, at all times, were able to pour into their territory. Miletus, despite the gallantry and excellence of her infantry, was compelled to renounce keeping the field ; for at each fresh attack her soldiers had to withdraw behind the walls, whence they beheld the burning of their homesteads and their crops, the falling of their olive trees under the axe. No courage is proof against a long-enforced inactivity. The fall of Smyrna was followed by that of Ephesus, and, if we except Miletus, there was scarcely a town that did not pay tributè towards the end of Crœsus's reign. On the other hand, the Lydian empire had by degrees spread as far as the Taurus range and the Halys, and the latter would thenceforth form its boundary line towards the Median empire. The treaty of 585 B.C., between Cyaxares and Alyattes, after years of warfare, provided a family alliance between the two dynasties, and fixed the great river as frontier of the two empires.¹ Thus Lydia belonged to Asia, be it from the despotic character of her monarchy supported by a large army, or the relations she had opened in the day of Gyges with Asur-nat-Sirpal, or those she subsequently entered into with the Medes, inheritors of the Assyrians, along with the Babylonian successors of Nebuchad-

¹ Herodotus (i. 73, 74) specifies all the peoples subject to Crœsus as if they had been subdued by him ; Crœsus, however, did but complete the work commenced by his predecessors. Nicholas of Damascus (Fr. 65) speaks of the war Alyattes waged against the Carians ; but the long struggle he likewise carried on with the Medes must have taken place near the Halys, perhaps on the eastern bank.

nezzar,¹ and the Saït rulers of Egypt.² On the other hand, the conquest of Ionia, in opening the Ægean to Lydia, awoke in her sovereigns a new train of thought: that of fitting out a fleet for the conquest of the Cyclades.³

The wildest ambition seemed to be within the grasp of these fortunate conquerors, when their power suddenly collapsed; induced not by internal turmoils and rebellion, but because of a revolution in the south of Iran, which caused supremacy to pass from the Medes to the Persians. In an evil hour Crœsus conducted an expedition across the Halys against the new masters of Anterior Asia; an indecisive battle was fought in Cappadocia, in which Cyrus would seem to have had the advantage, for he soon reappeared in Lydia, and completely routed an army hastily collected together, which was sent to impede his progress and prevent his advance on Sardes. All in vain. At the end of a fortnight's siege the Persians took by surprise a citadel deemed impregnable, in which, together with his family and his treasures, Crœsus had shut himself up.⁴ Sardes became the seat of a Persian satrap, and the Lydians from that day disappear as an independent nation. Though brief, the part they played as a political force was not without its effect on the unfolding of antique civilization.

Not the least curious feature of this history, covering the period between the enthronement of Gyges and the taking of Sardes, is the nature and character of the relations the Lydians entertained with the Greeks; since it would seem that hostilities and mutual acts of kindness went hand in hand together. Each day served to bring the two people nearer and unite them more intimately. Thus in the time of the Heraclidæ, Ardys, expelled from Lydia by a usurper, finds refuge in the Æolian city of Cymæ.⁵ Somewhat later, with the reign of the following dynasty, Lydian princes espouse Greek women, and give their daughters in marriage to Ionian nobles.⁶ A merchant of Ephesus supplies the sinews of war, and enables Crœsus to undertake a warlike expedition.⁷ Finally, when Cyrus, ready to march against Sardes, invited the Ionians to raise the standard of rebellion against masters they

¹ Herodotus, i. 74, 77.

² *Ibid.*, 77.

³ *Ibid.*, 27.

⁴ Herodotus, i. 75-84.

⁵ Nicholas of Damascus, Frag. 47.

⁶ Herodotus, i. 92; Nicholas of Damascus, Frag. 63; ÆLIAN, *Hist. Var.* iii. 26.

⁷ Nicholas of Damascus, Frag. 65.

had so often resisted, every town was loyal to a man.¹ If such was the state of affairs, it was because, despite the many evils the Mermnadæ had inflicted upon Ionia, they could rightly have assumed the style of "Philhellenic kings," as many Oriental princes did a few centuries afterwards.

If no means were spared to incorporate the maritime centres with their empire, this arose from the regard and admiration they had for the Greeks, and the consciousness of the superiority of their genius. Not only had Gyges and his successors sent rich offerings to the shrines of Asiatic and continental Greece,² but they also kept their artists employed,³ welcomed their philosophers to their court,⁴ and kept up relations of the most amicable nature with Miltiades, tyrant of Thracian Chersonesus, and the Athenian Alcmaeonidæ.⁵ If temples, during their campaigns in Ionia, suffered from the ravages of war, they were rebuilt, at their expense, on a grander and nobler style than before.⁶ Thus, it was Cræsus who supplied the money for the building of the temple of Artemis at Ephesus.⁷ And the Lydians, when menaced by Persia, turned for help to Sparta and Athens.⁸ What further proves the great popularity Cræsus enjoyed in the Grecian world, is the fact that his misfortunes did not rob him of the halo which had been his. Pindar, long after the fall of Sardes, cites him as an instance of the persistency with which fame preserves the memory of princes whose liberality has won them the esteem and admiration of their contemporaries: "The benevolent virtue of Cræsus," he says to Hieron, "dies not."⁹

That which helped not a little to reconcile the Ionians to the dominion of Lydia was the wealth of the latter. The Greeks were a shrewd, keen-witted people; they could behave heroically in an open fight, but when luck was against them, they readily

¹ Herodotus, i. 141.

² *Ibid.*, i. 14, 25, 50-52, 92; Theopompus, Frag. 184; MÜLLER, *Frag. Hist. Græc.*, tom. i.

³ Herodotus, i. 25, 51.

⁴ *Ibid.*, 27, 29. If chronology tells against Solon having been the guest of Cræsus at Sardes, there is a great degree of probability that Bias of Priene and Pittacos of Mitylene visited the place. No one would have dreamt of taking Solon to the Lydian court, had not other sages been right royally entertained there.

⁵ Herodotus, vi. 37, 125.

⁶ *Ibid.*, i. 19-22.

⁷ *Ibid.*, 92.

⁸ *Ibid.*, 56, 69, 70, 83.

⁹ PINDAR, *Pyth.*, i. 184: οὐ φθίνει Κροίσου φιλόφρων ἀρετά.

adapted themselves to the masters with whom more was to be gained than by staying away. The economy of the ancients was of the simplest; in their estimation the prosperity of the Lydians and the vaunted opulence of their princes were sufficiently accounted for by gold extracted from the depths of their mountains or picked up in the torrents of Tmolus.¹ But though it is pretty certain that veins of the precious metal were then won from auriferous rocks of quartz for the benefit of Lydia and Mysia,² nothing proves its having been obtained in quantities that would compare with the amount the kings of Macedonia quarried in after years from the flanks of Pangæus. As to the Pactolus, its reputation was doubtless due to the inflated language of poets; for the gold-finders who washed and sifted its sands, of a certainty, created but a small fraction, perhaps a very small fraction indeed, of the wealth Alyattes and Cræsus would seem to have possessed. Other agencies contributed a much larger share in the formation of treasures which were the wonder of the Greeks. In the first place should be named those soldiers who, after plundering half the peninsula in the interest of their chiefs, compelled the population to pay tribute; then came agriculturists, who utilized this vast and fertile territory, either as pasturage or arable land and vine-culture; craftsmen of either sex who, in the urban as in the rural workshop, practised those high-class industries already in vogue in the days of Homer;³ merchants who served as middlemen between the Greek ports and the productive centres, as well as the markets of the whole of Anterior Asia. Herodotus says that "the Lydians were the first retailers."⁴

¹ Herodotus, who has often been reproached with undue credulity, says nothing of the kind (i. 93, v. 101); he confines himself to the statement that the deciduous torrents of the Lydian mountains carry along with them gold particles. It is by much later writers that the Pactolus is described as the main source of Cræsus's wealth (Strabo, XIII. iv. 5). Upon the gold of Pactolus, consult TCHLATCHEF, *Le Bosphore et Constantinople*, 8vo, 1864, pp. 232-242. This traveller supposes that towards the seventh century B.C. the stream came upon a rich gold ore, which it disintegrated and worked out after a number of years, and as a matter of course ceased to produce gold in any quantity. The geological formation of Tmolus, as is well known, does not belie the above hypothesis; it accounts, too, for the exaggerated language of later times, as a reminiscence of what had once been a substantial fact.

² Strabo, XIV. v. 28; Pseudo-Aristotle, *περὶ θαυμασίων ἀκουσμάτων*, 52.

³ HOMER, *Iliad*, iv. 141-145.

⁴ *Ἱερῶτοι δὲ καὶ καπηλοὶ ἐγένοντο* (Herodotus, i. 94).

So stated the assertion is incorrect, since Egypt and Phœnicia had small vendors long before Lydia. What Herodotus means, and says after his own fashion, is that the Lydians had a natural turn and genius for trade, which in their hands acquired a singular activity. At any rate, it was not retail, carried on in the shops of some street in the bazaar, but wholesale trade that gave the Lydian Pythius his enormous wealth, which he placed at the disposal of Xerxes when the latter marched against Greece.¹ Even if we only reckon the actual worth of the precious metals, the capital Pythius is said to have possessed would amount to the considerable sum of more than £3,200,000.² Pythius was a citizen of Celænæ, situate by the head-springs of the Mæander, on the road which, a little beyond Colossoi, branched off in several directions, down the valleys leading to Miletus, Ephesus, Sardes, Magnesia, and Smyrna. I picture him as not unlike one of those Greek or Armenian merchants I have known in Asia Minor and Syria, for whom caravans travel between Smyrna, Messina, Alexandretta or Beyrout, and Angora, Konieh, Cæsarea, Aleppo, or Damascus.

Transport of raw products and manufactured objects served to swell the royal coffers; for it is probable that all imports and exports were heavily taxed, and that there existed fixed rates for everything sold, which were collected on the spot. Hence the gold and silver that filled the royal treasury chambers in the citadel of Sardes were derived from deductions made by the sovereign upon capital continually created and renewed by universal labour. No wonder Greek imagination found some difficulty in realizing this enormous accumulation of the precious metals.³ In the Hellenic world, capital was divided between a number of cities, and again subdivided between the well-to-do citizens of each town, so that it could not be condensed and amassed in one receptacle, as in Lydia, where the prodigality of the prince, however great it might be, could never exhaust it, since it always received more specie than it gave back to circulation. It is possible, nay probable, that what was in truth very considerable may have been exaggerated, notably by later writers, when their fancy

¹ Herodotus, vii. 27-29.

² *Ibid.*, *loc. cit.*

³ Archilochus found no more appropriate expression to denote the largest conceivable fortune than the following: Οὐ μοι τὰ Γύγω τοῦ πολυχρύσου μέλει ("The wealth of Gyves, he who is possessed of so much gold").

ran away with them. Nevertheless, when Herodotus enumerates the presents Cræsus consecrated to the Delphic shrine on the eve of his disaster, he doubtless reproduces the figures furnished him by local archives.¹ We know now from the inscriptions at Delos, those of the Parthenon and of many more sanctuaries, with what order and precision the great temples of Greece kept their accounts. It has been computed that Cræsus's offerings of massive gold, the weight of which, says the historian, was 117 bricks and 1 lion, are equivalent to 6448 kilogrammes, or, at the present value of gold, to nearly twenty millions of francs (£800,000). If to this be added all the other objects of unweighed gold and silver mentioned by Herodotus, and we reckon these at only one-half of the above sum, we shall find that the splendid liberality of the Lydian king amounted to nearly one million two hundred pounds sterling.² There was, then, an abundance of the precious metals in Lydia, the royal treasury was full to overflowing, and considerable quantities were distributed among private individuals. On the other hand, the great commerce of the country was one of traffic; it exported products derived from the soil or created by national industry; it not only imported foreign goods from the old cities of the East, but others manufactured nearer home, upon which Greek genius was beginning to put the stamp of its taste. Similar transactions added daily to the common wealth of the nation, and were facilitated by a metallic reserve far in excess of that of their neighbours, a fact which doubtless suggested to them a notion that had not occurred to their predecessors, the industrial peoples of remote antiquity, the Egyptians, Chaldæans, and the Phœnicians themselves.

The first step in commerce had everywhere been the barter of one species of goods or produce for another. Thus a monument at Memphis, in Egypt (Fig. 155), shows housewives going to market and purchasing shoes, vegetables, and liquids, which are paid for with fans, glass-beads, and other small objects. Inscriptions incised beside the personages render ambiguity as to the meaning of the picture impossible. Exact equivalents cannot be obtained by a similar process, nor is it an easy matter to balance differences when they exist. As soon as commercial transactions expanded, however, as soon as they were carried on not only

¹ Herodotus, i. 50, 51.

² P. DE TCHLATCHEF, *Le Bosphore*, etc., 8vo, pp. 237, 238.

between the inhabitants of one village, or of one town, but between men of different tribes and different nations, the need of a medium of exchange was felt, which should facilitate despatch of business, and which, by common consent, should always and everywhere be accepted in discharge of all and any purchase, without obliging the vendor, by way of compensation, to accept goods he did not require. This medium, at once commodious and easily transported, possessed, too, of intrinsic value which was recog-



FIG. 155.—An Egyptian market, from a tomb painting of the fifth dynasty. *Gazette Arché.*, 1880, Plate XVI.

nized by all, was supplied by the precious metals, gold and silver, and, to a certain extent, bronze also. At the outset their use was restricted to dust and irregular pieces; by degrees, however, they were replaced by crenated bars, ingots, rings, and plates, or flat pieces, with notches so graduated as to correspond with the scale of weights, down to the feeblest. Ingots of this kind are often figured on the monuments of the civilized nations of Egypt and of Anterior Asia, in the very act of having their weight tested. This is shown in our woodcut (Fig. 156), as well as in scores of inscriptions. Ingots were a primary form of specie, which, though showing a decided advance, still left much to be desired.¹

¹ Upon the coinage of the early nations, see FR. LENORMANT, *La Monnaie dans l'Antiquité*, tom. i. pp. 93-124.

One could never be sure as to the genuineness of their composition; hence assays became indispensable for ascertaining weight, fineness, and portion of alloy.

The most important innovation, the true innovation of genius, which transmuted the still imperfect ingot into money, was the adoption of a constant mark which, affixed to that of the sovereign, should by its bare presence remove all suspicions. By this official stamp the State vouched for the standard and weight of its metallic coinage, which it had issued "as signs of value," and

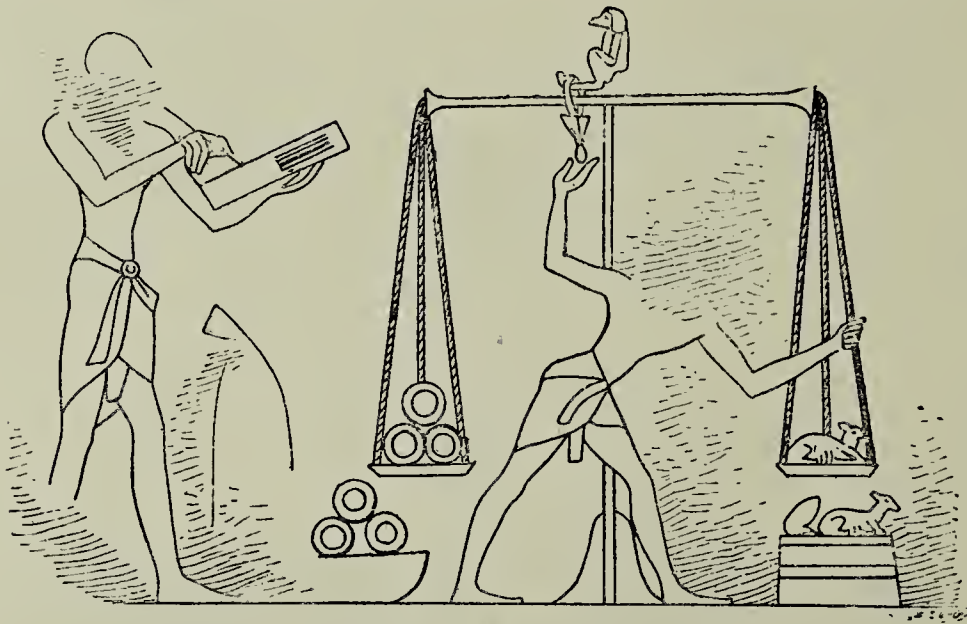

FIG. 156.—Weighing gold ingots in Egypt. After a painting at Thebes. WILKINSON, *The Customs and Manners of Ancient Egyptians*, 2nd edit., vol. i. Fig. 7.

“the world was saved from perpetual weighing;”¹ whilst public authority was rewarded for interposing in the interest of the community, by having its money accepted without question. By this one act the specie acquired a current value which had not belonged to the ingots of the preceding epoch. At the same time the service rendered to commercial transactions put the government in a position to circulate its coinage in every country subject to its jurisdiction. Strictly speaking, the right assumed by authority is only legitimate as far as the money is genuine and what it purports to be; should it fail of these conditions, no enactment of the law, however stringent and severe, will make it effective, or prevent the depreciation of a coinage whose nominal worth is much below its intrinsic value.²

No coined money—as is now proved—was struck before the

¹ ARISTOTLE, *Polit.*, I. vi.

² LENORMANT, *loc. cit.*, pp. 93, 94.

opening years of the seventh century B.C., and the honour of the invention rests between the Greeks and the Lydians; that is to say, between two nations almost sisters in blood, and both occupying the basin of the Ægean Sea. Two traditions obtained in the ancient world in regard to it, both supported by authorities of the greatest weight. The lexicographer Pollux, a judicious and well-informed man, in face of the conflicting evidence found in various authors, hesitates "to settle the question as to whether the Argian Pheidon or the Lydians first struck coins."¹ The question is precisely where classic antiquity left it.² For some—Ephorus, followed by Strabo,³ Ælian,⁴ and a goodly number of later writers,⁵ as well as continental Greece generally—the first coins were those bearing a tortoise on the obverse, which Pheidon, king of Argos, caused to be struck in the island of Ægina, which formed part of his dominions. On the other hand, Herodotus says, "To our knowledge the first men who struck money of gold and silver were the Lydians."⁶ The same testimony is borne by an older writer, Xenophanes of Colophon, who made the ancient history of Lydia his special study.⁷ The gold of Gyges, the staters of Cræsus, were likewise adduced as having passed as currency.⁸ The evidence we now possess enables us to assert that the two traditions rest on a real base, and coincide with two distinct facts; namely, that the first gold coins were issued by the kings of Lydia, and the first silver money by Pheidon in Ægina. This last fact is connected with the institution of the oldest system of weights and measures known in Peloponnesus, and is universally attributed to that prince—whose authority seems to have extended over a large portion of that province—by historians who have handled the subject.⁹ But which of the two monetary issues is entitled to

¹ Pollux, ix. 83.

² We do little more than give a summary of Lenormant's very precise and lucid exposition (*La Monnaie*, I. iii. 2).

³ Strabo, viii. vi. 16.

⁴ ÆOLIAN, *Hist. Var.*, xii. 10.

⁵ The *Paros Chronicles* (i. 45, 46) record certainly the fact that silver coins were struck at Ægina by Pheidon, but nothing is said as to having been the first issued.

⁶ Herodotus, i. 94.

⁷ Pollux, ix. 83. Xenophon was born towards the end of the seventh century; he is the author of a poem entitled *Κτίσις Κολοφῶνος*.

⁸ Pollux, iii. 87. *Γυγιάδας χρύσος, Κροίσειοι στατήρες*.

⁹ Herodotus, vi. 127; PLINY, *Hist. Natur.*, VII. lvii. 7 (ed. Littré); Pollux, x. 179, from whom we learn that Aristotle, under the heading "The Constitution of the

priority? To whom should the honour of the invention be attributed with a greater degree of probability?

The witnesses in favour of the kings of Lydia seem more worthy of belief than those upholding the pretensions of the Æginetans; they are older and nearer the facts they purpose to relate. Xenophanes was a contemporary of Alyattes and Cræsus, and had seen the use of coinage gradually spread from the Lydian empire to the Ionian cities. If Herodotus lived after the fall of the Mermnadæ, he yet was the senior by a hundred years or thereabouts of Ephorus; more than this, he was born and his youth was spent in a region where, in his day, considerable quantities of specie, formerly issued by the Lydian monarchs, were doubtless still in circulation, and he was more curious and better informed than the rhetor-historians of the Isocrates school. The fact that the self-conceit of the Greeks would not permit them readily to acknowledge the superior claim of the Lydians is another reason why we should believe the testimony of Xenophanes and Herodotus; for nothing short of titles of unquestionable authority would have compelled the former to yield the palm of honour to others.

Historical chronology cannot be depended upon to solve the question, since no date is more controverted than that assigned to the reign of Pheidon. If certain instances would seem to mark the eighth or even the ninth century B.C. as a possible date, there are others which oblige us to go down to the middle of the seventh century, in order to find, in Peloponnesus, a range of circumstances in accord with the great and special part attributed to Pheidon. Hence it is that the eminent historian of Greece, Ernest Curtius, has embraced the latter hypothesis.¹ In his estimation Pheidon was a contemporary of Gyges, but somewhat his junior, and still a youth when the Mermnad bore down all opposition and firmly seated himself on the throne of Lydia.

The best way for settling the point at issue is to address oneself to the monuments, for superficial inspection will suffice to bring out clearly the importance of the witnesses we have adduced. No extant series of coins bear so primitive and old an aspect as the silver pieces of Ægina, and certain "electrum" examples

Argians," subjoined to his great collection, devoted part of a chapter to the weights and measures instituted by Pheidon; the *Paros Chronicles*, i. 45, 46.

¹ E. CURTIUS, *Hist. of Greece*, tom. i. p. 299, n. 3.

which are generally ascribed to the kings of Lydia. The latter, as struck by the Lydians, will alone engage our attention in this part of our history. Our reason for assigning a Lydian origin to them rests upon the following data:—The vast majority of similar pieces (found in our museums) were collected in the environs of Sardes.¹ The type seen on them is in harmony with the hypothesis we uphold; it is a lion, whose image Crœsus sent to Delphi,² which, carried round the ramparts of Sardes,³ made them impregnable, and, last not least, it is the animal sacred to Cybele, the great goddess of Asia Minor. In other specimens the head of the lion is opposed to that of the bull, and numerous examples have already shown us how dear was the device to Asiatic art; the juxtaposition of the two animals would seem to have had a symbolic value.⁴ Moreover, many of these pieces are in electrum, that is to say, the metal *par excellence* of Lydia.⁵ The Greeks gave the name of *electrum*, pale gold, to a natural alloy of gold and silver in varying quantities. The electrum obtained from the auriferous sands of Tmolus and minted by the Lydians contains seventy-three parts of silver to twenty-seven of gold.⁶

The use of a coinage, of which the alloy was not constant, is in itself a strong presumption of remote antiquity; since Herodotus tells us that later, in the reign of Crœsus, moneyers took to refining gold destined for coinage, so as to bring it nearer to standard. The form and aspect of the pieces in Lydia, which are little more than ingots ovoid shaped, betray the gropings of a nascent art far more effectually than imperfection of the metal employed. Then, too, on these kind of huge lozenges flattened at the rim, appear hollows or striæ on one side, and three deeply incised stiletos or puncheons symmetrically arranged on the other.

¹ RAWLINSON, *Herodotus*, i. p. 713.

² Herodotus, i. 50.

³ *Ibid.*, 48.

⁴ *Hist. of Art*, tom. ii. Fig. 443; tom. iii. p. 652, Figs. 475, 476, 544, 624. One of these stiletos is in the shape of a fox's head, symbolic of Dionysios, who in Lydia was called *Bassareus*, fox. *Bassara* was the name of the fox among certain barbarous people (*Thesaurus*, s.v.).

⁵ SOPHOCLES, *Antigone*, 1037–1039:

Κερδαινετ' ἐμπολάτε τὸν πρὸς Σάρδεων
ἤλεκτρον, εἰ βούλεσθε, καὶ τὸν Ἰνδικὸν
χρῦσον.

⁶ BARCLAY V. HEAD, *Hist. Numorum*, Introduction, Plate XXXIV.; FR. LENORMANT, *La Monnaie dans l'antiquité*, tom. i. pp. 190–194. The periphrase “white gold,” λευκός χρυσός, was sometimes used instead of ἤλεκτρον by the Greeks (Herodotus, i. 70).

The oldest coins of Ægina have a far-off resemblance with the metallic bars of former days, which served as medium of exchange; the ingots are still oblong instead of approaching a more or less circular shape;¹ so that their primitive rough appearance might at first sight be taken to denote priority of date as against those of Lydia. But if the puncheons seen on the coins we attribute to Gyges show better workmanship than those issued at Ægina with a tortoise impressed on the obverse, the difference admits of easy explanation. In the seventh century B.C., Asia Minor was greatly in advance of Greece; her art and the crafts allied thereto testified to a development and surety of hand which training and experience alone can give. The fact which apparently decided the question of priority of date is that the oldest coins of Lydia, as compared with those heading the Ægina series, do not, as these, entirely fulfil the conditions which, in antiquity, constituted and defined coinage. The pieces clearly belong to an early epoch of transition; they are still ingots, of the kind once circulated in Egypt and throughout Asia, but the stamp of public authority has conferred upon them all the essentials requisite in a coinage, as a medium of traffic and public convenience. On the other hand, a gigantic step onward was made with the advent of the coiner's block, when impressions in relief could be obtained; and this enormous progress is non-existent in the earliest gold staters of the Lydians. Consequently pieces, no matter how rude in make, but on which types in relief appear, have no claim to be considered as the oldest, since they carry the mark of a new and progressive stage in the coiner's art; and to this stage belong the oldest silver coins of Ægina.²

Herodotus would seem, then, to be right when he awards the honour of the invention of coined money to the Lydians; save that it is inaccurate, as regards the Lydia of that time, to speak of

¹ In the famous temple of Hera, at Argos, were shown bars (*ὀβελισκοί*) said to have been consecrated by Pheidon, as a standing witness of an old usage his inventions had caused to be set aside (*Etymol. Magnum, vide ὀβελισκος*).

² For a comprehensive survey of the Lydian coinage, besides Lenormant, see BARCLAY V. HEAD, *The Coinage of Lydia and Persia*, which appeared in the *International numismata Orientalia* from 1874-1877 (Trübner and Co.). In it (p. 19) the author discusses in full the reform attributed to Cræsus. Each number is accompanied by excellent plates in photogravure, which form a separate work. The same questions are more briefly treated in *Hist. Numorum*, pp. 545, 546, by the same author. M. C. SOUTZO, *Systèmes monétaires primitifs de l'Asie Mineure et de la Grèce* (*Revue Roumaine d'Arché., d'histoire, et de philologie*, tom. ii., 1883).

gold and silver as having been issued conjointly. The latter should have been omitted. The oldest silver coins that can be assigned to Lydia, with any degree of probability, are of a much less archaic type than the electrum examples; and numismatists agree in not carrying them back beyond the age of Cræsus. This prince is generally credited with the introduction of a double standard, pure gold and pure silver, which took the place of electrum, the standard of which was not rigorously defined. This wise and happy reform, it is said, largely contributed to the increase of commercial enterprise and the wealth of his kingdom. Be that as it may, the silver coins under consideration, whether they were struck in Lydia or in the Greek cities of Asia Minor, are markedly younger than the first tortoise examples of Ægina. As these, their type is in relief, and of good workmanship. It is highly probable that the mint at Ægina issued the first silver coins.

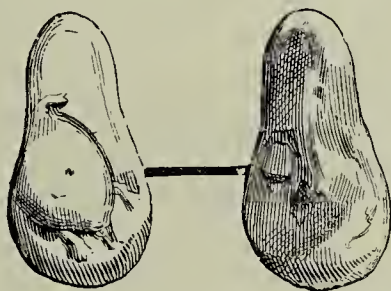

CHAPTER II.

ART IN LYDIA.

ARCHITECTURE.

WHEN we described the necropolis and the tumuli in the neighbourhood of Smyrna, it was with a certain degree of hesitancy that we connected the above monuments with the quasi-fabulous monarchy of the Tantalidæ.¹ We feel no such embarrassment when we try to fix the origin and approximate date of the cognate tombs of the necropolis near Sardes, called *Bin Tepe* (the Thousand Mounds).

The kings of Sardes had their sepulchres on the farther side of the Hermus, to the northward of the town and close to it (Fig. 157). The monuments were still pointed out to travellers in the day of Herodotus and Strabo. The descriptions of the site, form, and dimensions of these tombs by ancient writers, are sufficiently near reality to have enabled modern explorers to identify them. In a remarkable passage that will bear repetition, Herodotus has the following :—²

“ In Lydia is seen a work much superior to those we admire elsewhere (I would, nevertheless, except the monuments of the Egyptians and the Babylonians); it is the tomb of Alyattes, the father of Cræsus. The wall around it consists of large stones, and the rest is of earth heaped up. It was erected at the expense of merchants who retail on the market-place, of craftsmen and courtesans. Five termini, put on the top of the monument, were extant in my time, and inscriptions indicated the share which each of the three classes had had in the building. Measurements show that the portion of the courtesans was far the largest, because every one of the girls in the country of the Lydians practises prostitution ;

¹ See pp. 48-53.

² Herodotus, i. 93.

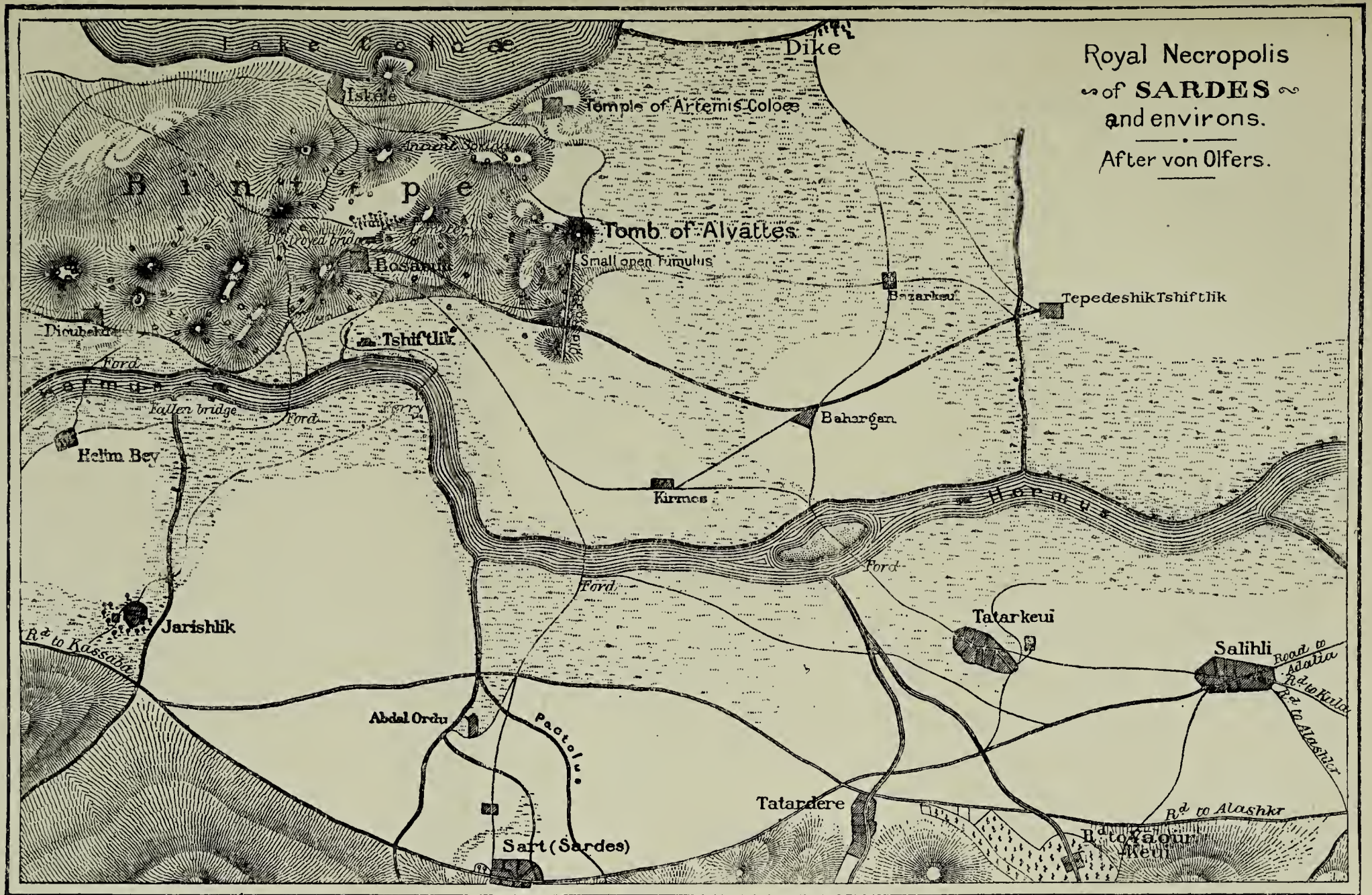

L. Thuillier. Del.

Scale.

1/2 Kil

FIG. 157.—Royal necropolis of Sardes and its environs. After Von Olfers' map in *Abhandlungen* of the Berlin Academy, 1858.

they earn their dowry by it, and continue the trade until they marry; they have the right to choose their husbands. This monument is 6 stadia 2 plethra (1171 m. 65 c.) in circumference, and 13 plethra (400 m. 75 c.) wide. Close by is a large lake, which, say the Lydians, never dries up. It is called the Lake of Gyges. All is exactly as I have said."

To this graphic account may be added the bearings given by Strabo of these respective sites, the only portion of his narrative which adds to our knowledge: "Forty stadia (7400 m.) from Sardes is a lake called by Homer Lake of Gyges, but which sub-



FIG. 158.—View of tomb of Alyattes, from the south. Von Olfers, Plate IV.

sequently changed its name into that of Coloæ. . . . The tombs of the kings are sprinkled around the Lake Coloæ; that of Alyattes (Fig. 158) looks towards Sardes; it is an immense embankment of earth, kept in place by a tall base of stone." After alluding to the statement of Herodotus as to the share girls of bad repute had in the building of the tomb, he adds: "This explains why the royal mausoleum was formerly called the Courtesans' Monument. Certain historians assure us that the Lake Coloæ was excavated by the hand of man to receive the surplus waters of the rivers" (XIII. iv. 5, 7).

It would be impossible to have clearer or more exact indications;

nevertheless Strabo errs in placing Coloæ so close to Sardes.¹ The only lake near the town is the Mermereh Gheul; the artificial knolls, called Bin Tepe, some of colossal size, are situate on the southern bank of the stream. Seen at a distance, from Sardes for example, they might be taken for low hills closely packed together; when near them, however, they appear in

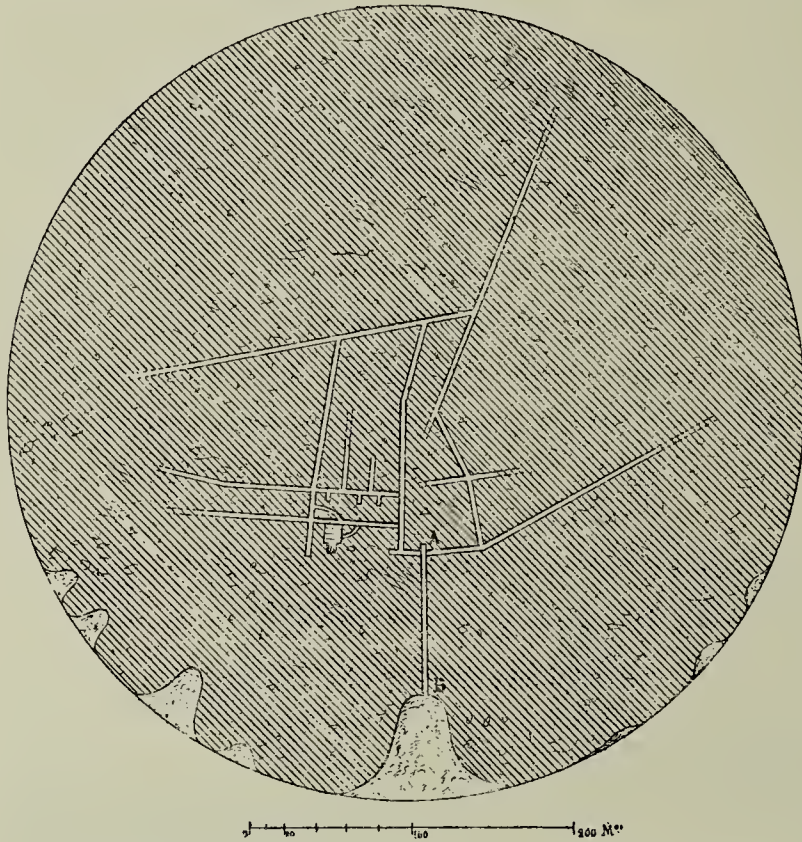

FIG. 159.—Plan of tomb of Alyattes. Von Olfers, Plate III.

regular rows which follow the undulations of the ground until they are lost to sight. Their symmetrical arrangement is so conspicuous as to have struck every traveller who has visited them, so that no doubt is left in their mind that they were artificially made.² From the fact that there is little or no difficulty in exploring them, it might have

been expected that they would have been searched long ago. From some unexplained cause, however, these masses were left untouched until the consul-general of Germany, Spiegelthal, had the happy idea of sounding their depths. His first attempts were made around the smaller tumuli, but he presently gave up the undertaking and attacked the mound, which for all the world looks like a low hill, and whose exceptional dimensions singled it out as the tomb of Alyattes.³

¹ The real distance is but some twelve kilometres; the discrepancy is probably due to some confusion in the figures which crept into the text. It should be remarked that the suburb of Sardes, in the time of Strabo, may have stretched far away to the northward, across the plain.

² CHANDLER, *Travels*, p. 263; HAMILTON, *Researches*, tom. i. pp. 145, 146; TÉXIER, *Asie Mineure*, 8vo, pp. 258, 259; PROKESCH VON OSTEN, *Erinnerungen*, iii. p. 162.

³ *Monatsblatt der k. P. Akademie der Wissenschaften zu Berlin*, 1854, pp.

In its present state this tomb is still sixty-nine metres above the level of the plain. The turf covering the mound was cut to some depth around its base, when the stone construction which formed the shell of the vault was disclosed; more cuttings were made across the mass to the centre, occupied by the funereal chamber, in which, doubtless, had been deposited the royal body, but which the explorers found empty.

During his borings, Spiegelthal found traces of other galleries that, in all likelihood, had been made in antiquity by treasure-

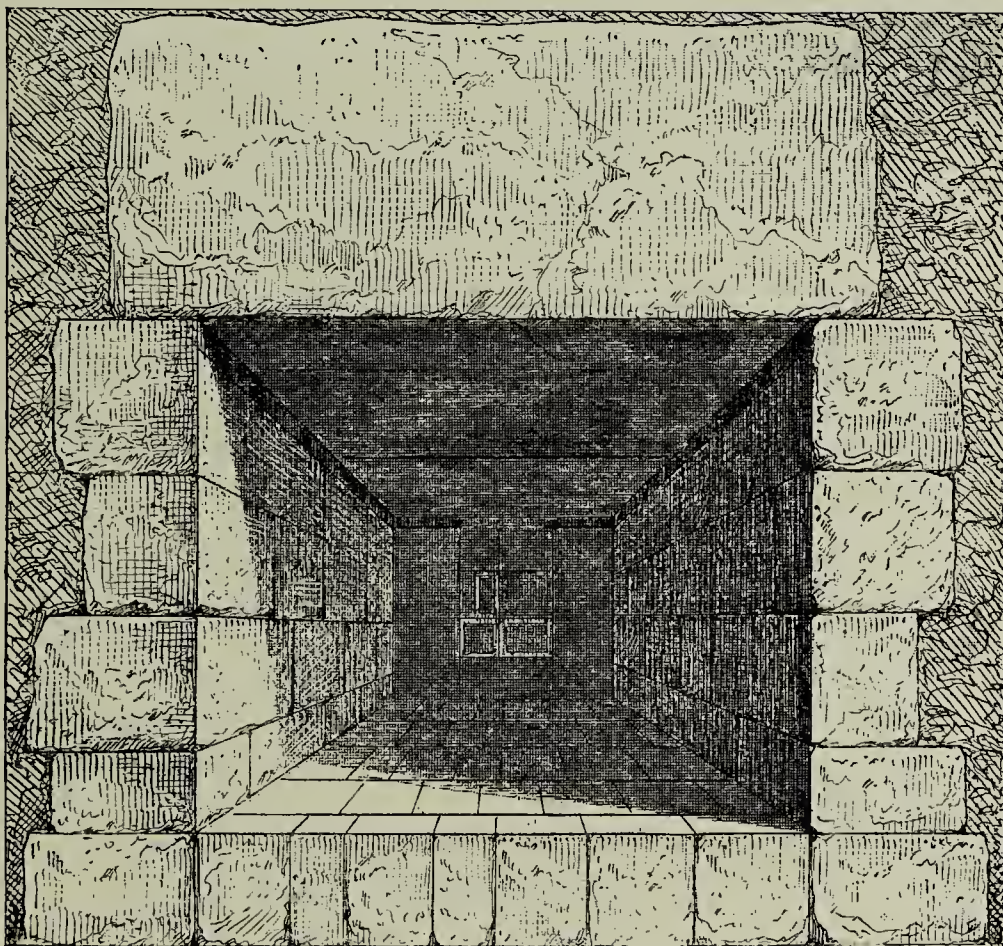

FIG. 160.—Perspective view of the interior of tomb.

seekers (see plan, Fig. 159, A, B). He followed their direction and thus attained his goal.¹

700-702; and in *Abhandlungen* of the same learned society, 1858, pp. 539-556, appeared a memoir, by Von Olfers, entitled "Ueber die Lydischen Koenigsgraeber bei Sardes und der Grabhuegel des Alyattes nach den Bericht des Kaiserlichen Generalconsuls Spiegelthal zu Smyrna," with lithographed plates.

¹ The trench A, B in map (Fig. 159) was opened by Von Olfers, when he came upon galleries that had been excavated by treasure-seekers. By clearing and following them, he reached the mortuary chamber.

The situation of the vault is fifty metres south-west from the centre. The walls are built of large blocks of grey marble, smoothed over and finely cut, and held together by leaden dovetails (Fig. 160). But right at the top, beneath the ceiling, runs a band, forming a kind of frieze, which was left in the rough. After the deposition of the body, the door was closed with marble slabs, smoothed away at the edges, whilst the rest is rough-cut (Fig. 161). In front of the door is a passage, which was entered

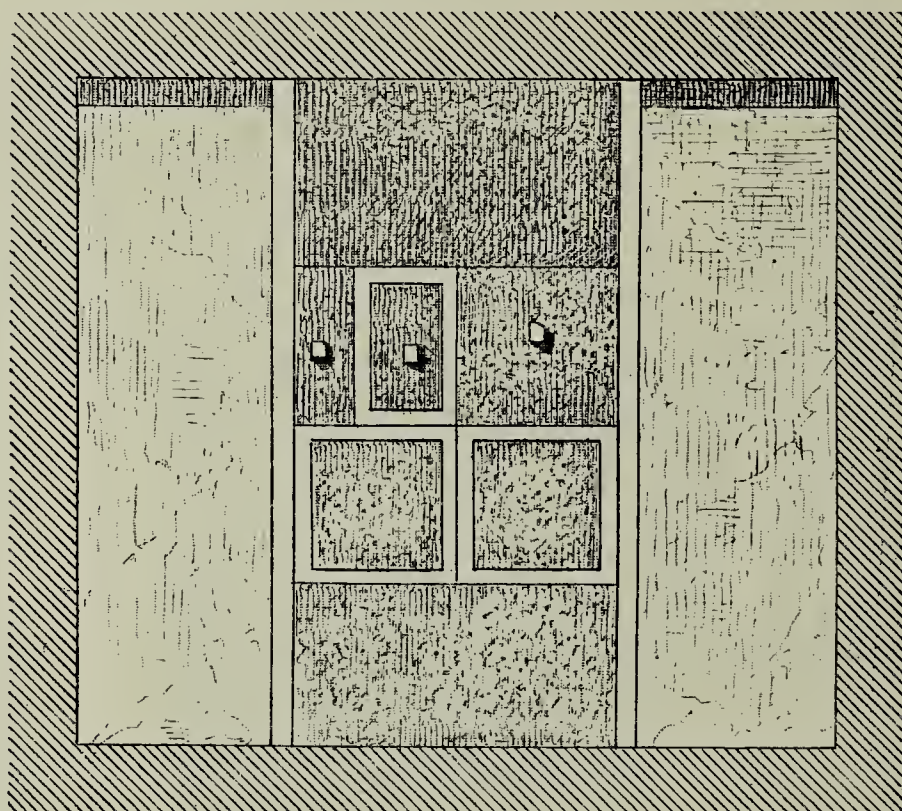

0 5 10 15 M^{es}

FIG. 161.—Doorway. Inner view of vault. Von Olfers, Plate IV.

from the south, looking towards Sardes (Fig. 162). Its walls are of square blocks of the same marble; they appear channelled, and contrast with the plain faces and framing, scarcely touched by the chisel. As soon as the vault was closed, huge stones were rolled and heaped against it, the better to block the passage. The roof is arched, but the vault, though mediocre, has not moved. The covering of the mortuary chamber consisted of horizontal slabs, some of which have been displaced by earthquakes. No trace of the sarcophagus was found; it doubtless was of wood, and destroyed by the first treasure-finders. On the other hand, numerous fragments of vases of Oriental alabaster

and of clay were picked up. Above the ceiling of the mortuary chamber, charcoal was discovered heaped up to about two metres—the remains apparently of the temple-store which served to consume funereal sacrifices.

The royal mound consists of two conical masses put one upon the other, each with a truncated summit, the topmost being some-

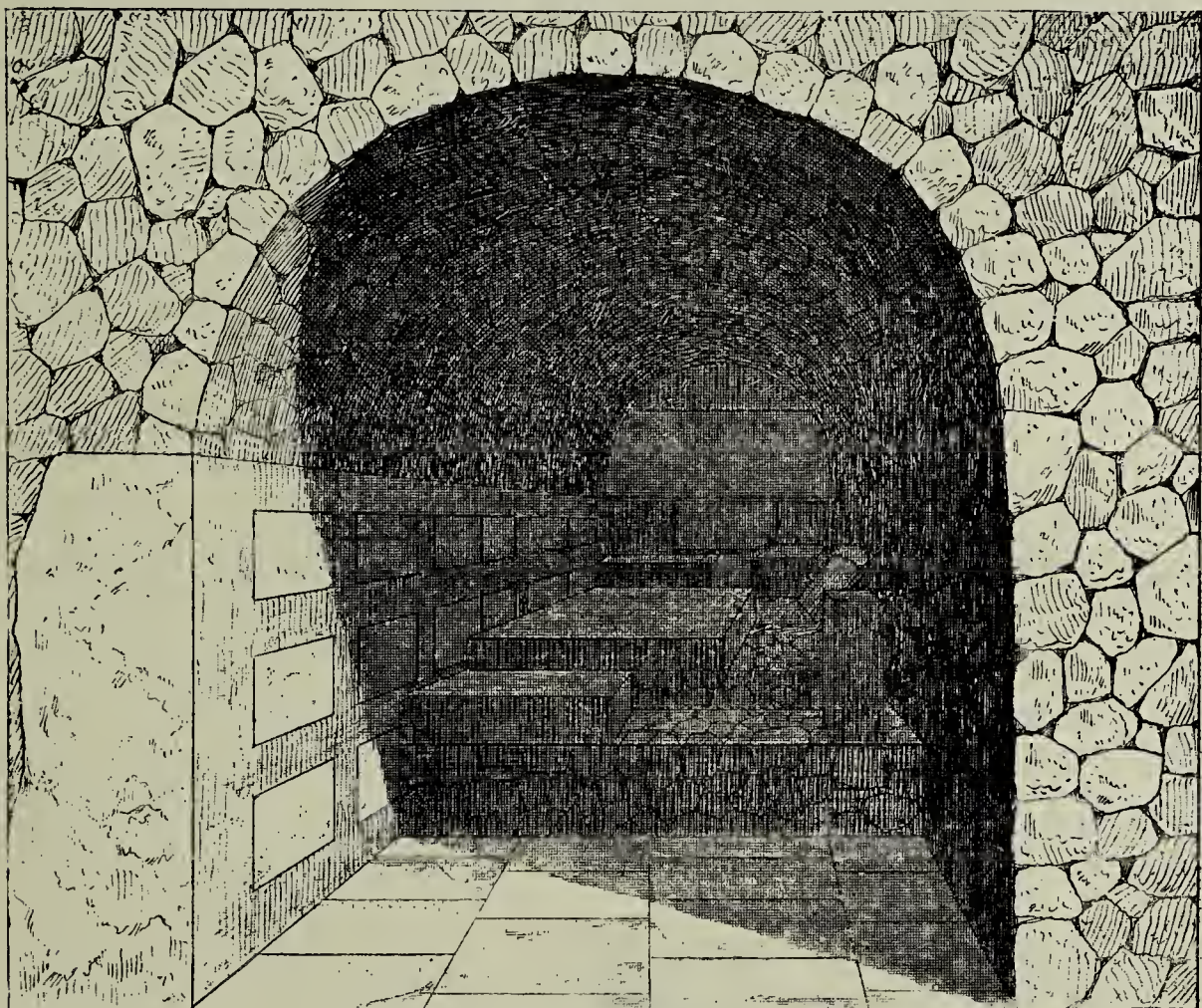

FIG. 162.—Passage. Von Olfers, Plate IV.

what more depressed than the one below (Fig. 163). The lower part of the cone, to the height of eight metres, is native rock; then comes a circular wall of large units, fixed without mortar, which serves to keep in place the earthwork within the circle. The whole may be likened to a pie, of which the wall is the crust.¹ Here and there, the rock shoots up above the surrounding level, and projects internally beyond the wall line into the void, which it helps to fill (see plan, Fig. 159). Between these peaks, the artificial mass was disposed in regular layers, one of clay, one of

¹ The total height of the tumulus is sixty-one metres, and the artificial mound from the top of the built wall, forty-three metres.

yellow mud, and a third of lime mixed up with sand. Measured from the level of the plain, the circular base is twenty-six metres ; it supported the mound properly so called, which had a facing of bricks at least towards the apex (Fig. 164), and ended in a plat-

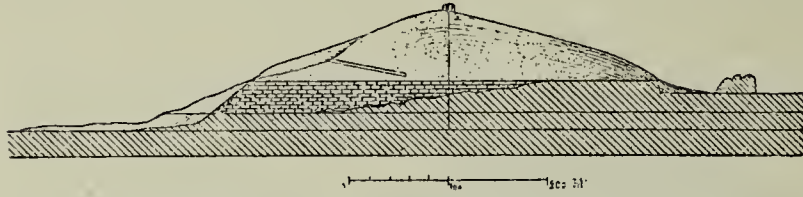

FIG. 163.—Section of tumulus through south-north line. Present state. Von Olfers, Plate II.

form, where the excavators found one of the boundary stones named by Herodotus, lying on one side, but still *in situ*. Its diameter at the base is 2 m. 85 c. (Fig. 165). In it we recognize a phallus akin to those encountered in the Tantaleis necropolis. Another, one-fourth the size of this, was discovered at the foot

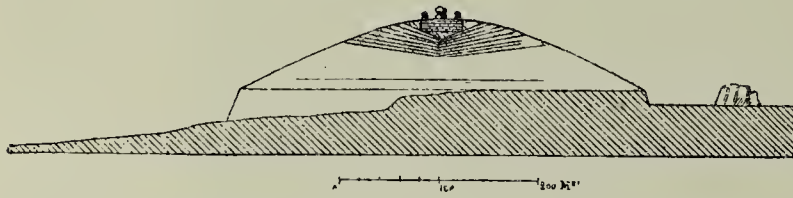

FIG. 164.—Section of restored tumulus. *Ibid.*, Plate IV.

of the mound. To judge from the respective bulk of the two stones, as well as the situation in which they are found, we may conclude that the larger was that which once stood in the centre of the platform, whilst the other was one out of the four distributed around it, and which, being close to the edge, rolled over the talus.

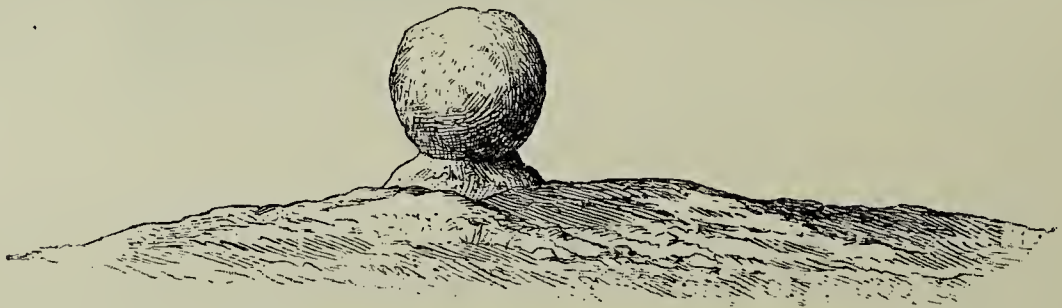

FIG. 165.—One of the stone termini. *Ibid.*, Plate III.

The remaining three cannot be far off, and are, doubtless, buried under accumulated *débris*. There is no trace of an inscription anywhere about the stones. Herodotus did not actually climb the sepulchral mound of Alyattes ; he was content to see it from Sardes. His mention, therefore, of a stela that should have been somewhere on the outside of the monument may be due to one of two causes. Either he was the dupe of his guide, as every

traveller ignorant of the language of the country he happens to visit knows to his own cost, or his memory may have played him false, and made him confuse the said stela with the milestones of the upper platform.

On the other hand, the measurements given by the historian coincide very nearly with those taken on the spot, and must of a necessity relate to the same monument. The one error in his computation is clearly due to his having mistaken the diameter for the circle, since a circle of 1172 m. would yield a diameter of 373 m., and not 403 m. If we take the 373 m., which are the real figures of Herodotus, and compare them with the 355 m. obtained by Spiegelthal for the diameter measured at the foot of the wall, we shall only find a divergence of 18 m. between the two sets of measurements. Accepting Spiegelthal's figures as final, the monument was 1115 m. round.

If these dimensions be set against those of the Cheops Pyramid, they will make one realize how the Lydian monument should have reminded the historian of what he had seen in Egypt and Chaldæa. The Great Pyramid is certainly taller than the tomb of Alyattes, but its circumference is much less, being no more than 935 m. 96 c. Then, too, in its pristine state the Lydian sepulchre must have looked far more imposing than it does now, with its wall buried under rubbish, and its sides deformed by deep furrows or sinkings. The deepest of these looks towards the old capital (Fig. 157). Traces of a carriage-road have been found in the direction of the Hermus and Sardes, with which it communicated either by a bridge or a ford. It led to the necropolis, and thence to a temple of Artemis Coloæ not far distant.

The monument, then, considered as a whole, was not devoid of grandeur, and testified, if nothing else, to a great effort. The tomb of the warlike monarch, who had moved the frontiers of Lydia on to the banks of the Halys, was the principal ornament of a necropolis embracing sepulchres other than royal mausoleums; since no less than a hundred distinct mounds have been made out,¹ whilst in a district where tumuli obtained, we may take it that many more have been destroyed, either by the action of water or the ploughshare.

As stated above, Spiegelthal began by exploring some of the

¹. The figure is that given by Spiegelthal; Hamilton and M. Choisy say about sixty mounds.

smaller tumuli, but the public has not been given the result of his researches. Hence our information in regard to them is derived from a work lately published by M. Choisy, a French traveller, who visited the Lydian necropolis in 1875. When he reached the spot he discovered that several tombs had recently been opened and cleared—by whom no one seemed able or willing to tell—so that he had ample opportunity to study the secondary tumuli, and analyze the character of their architecture.¹

Despite slight differences which it is unnecessary to point out, these tombs may be reduced to one single type (Fig. 166). Thus

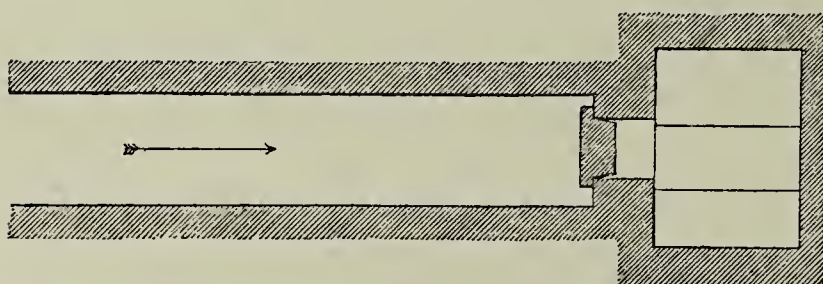

FIG. 166.—Lydian tomb. Plan. CHOISY, *Note*, Fig. 1.

the mortuary chamber beneath the conical mass is a low and tiny apartment flush with the soil, whose dimensions are appreciably uniform, no matter the importance of the covering mound. In round numbers these dimensions are 3 m. 50 c. for the principal face, 2 m. for the opposite side, and 2 m. in height. The direction of the main sides is east and west. The walls are of hewn blocks, with counter-walls of small uncut stones or rubble at the back. Large flags formed the ceiling of the chamber. A door pierced in the southern face was closed by a stone plug that exactly fitted the door-frame. It communicated with a passage that ran for some distance, and was presently lost in the mass itself. The wall-facings of the apartment were left, as a rule, in an incomplete state, whilst the passage is subdivided into sections, added on at different times, whose execution gets ruder in ratio to its distance from the mortuary-chamber. All the details betray evident precipitation.²

M. Choisy completes these general indications with a double set of drawings. The main dimensions of the first tomb (Fig. 164) are the following: length of chamber, 2 m. 94 c.; width, 2 m. 1 c.; height, 2 m. 2 c.

Passage: width, 1 m. 51 c.; height, 1 m. 98 c.

¹ AUGUSTE CHOISY, *Note sur les tombeaux Lydiens de Sardes avec planches et plusieurs figures dans le texte* (*Revue Archéologique*, N.S., tom. xxxii. pp. 73-81).

² *Ibid.*, p. 74.

Fig. 167 gives a perspective view of the slab that served to close the cell, of which a good view is given in plan. Transverse section (Fig. 168) shows the door open. In Fig. 169 we have two sections of the passage, built of well-prepared units; the sections are pieced on, but not united one with the other; the remaining portion of the gallery is of small stones, and the whole surrounded by the earth-work.

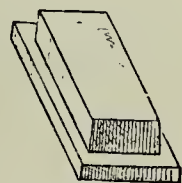

FIG. 167. — Sealing slab. Choisy, Fig. 4.

The next tomb (Figs. 170-173) is a variant of the preceding one. The piers have an inward salience, whose incline is about 20 c. per metre. Dimensions of chamber: length, 2 m. 83 c.; width on the ground plane, 1 m. 94 c.; width flush with the ceiling, 1 m. 52 c.; height, 2 m. Width of passage: 1 m. 29 c.; height, 1 m. 72 c.

The last monument (Figs. 174, 175) is a simple chamber with-

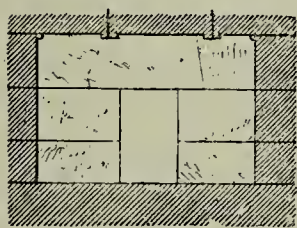

FIG. 168. — Transverse section. *Ibid.*, Fig. 3.

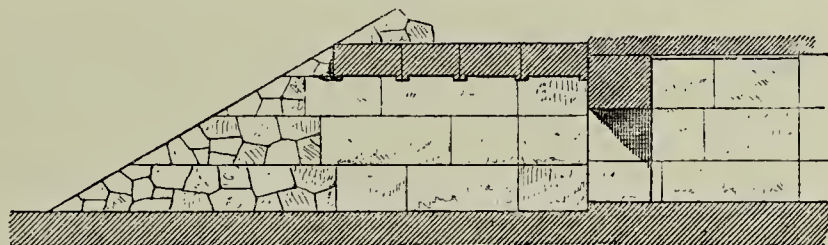

FIG. 169. — Longitudinal section. *Ibid.*, Fig. 2.

out any vestige of a passage, 2 m. 60 c. by 1 m. 65 c., and barely 1 m. 19 c. in height. In Fig. 176 are figured the two sides of the unfinished casing, much enlarged; they are supposed to be raised from the ground and seen from below. Fig. 177 indicates the place usually occupied by the chamber, and the gallery by which it is approached. The earth-work has been obtained by conical layers regularly arranged around the axis of the mound. The lower zones have a steep incline, which grows less with each successive band.

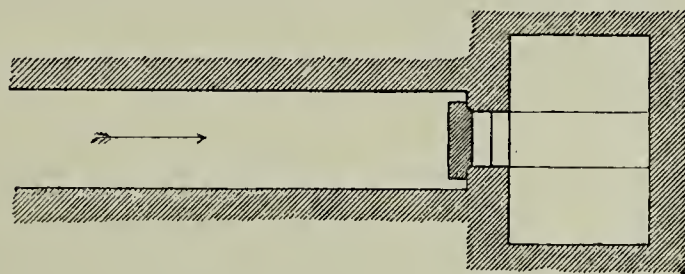

FIG. 170. — Lydian tomb. Plan. *Ibid.*, Fig. 5.

“Indications such as these permit us to understand how the work was carried on. Two gangs were employed at it; one composed of journeymen to raise the earthwork, and the other of masons to build the vault. For the greater convenience of the

two parties, whom close contact would have seriously hindered, the tomb-chamber was built away from the centre, so as to leave here an open space for depositing the material which was to form

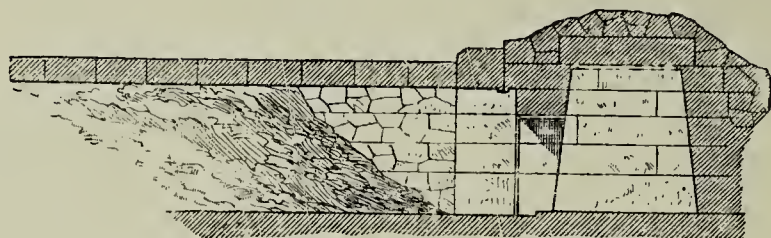

FIG. 171.—Longitudinal section. Choisy, Fig. 6.

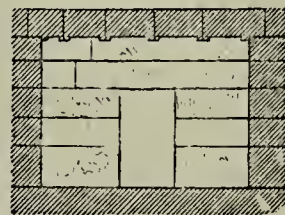

FIG. 172.—Transverse section. *Ibid.*, Fig. 7.

the mound-core. The earthwork went on adding to its size by degrees until it reached the cell which it encompassed, all but a

narrow space reserved for the passage branching off on the south face. As the filling progressed and grew larger, the gallery, whose function was to keep the entrance free, was lengthened out; hence the fragments of masonry everywhere observable about these passages. Here and there even, to save time, dressed stones were abandoned for small units in their native rudeness (Figs. 169, 171). When complete, the body

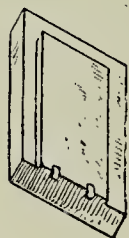
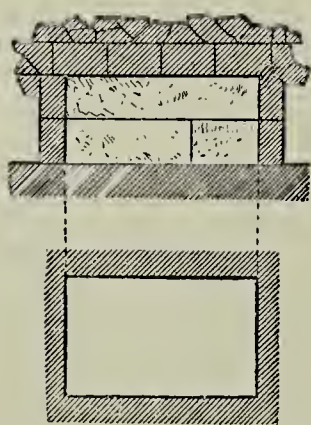

FIG. 173.—Sealing slab. *Ibid.*, Fig. 8.

was deposited in the tomb, the door was sealed, and the cell left to itself amidst its earth surroundings; but its smallness, coupled with careful construction, saved it from being crushed under the enormous pressure.



FIGS. 174, 175.—Lydian tomb. Plan and longitudinal section. *Ibid.*, Figs. 9, 10.

“The galleries by which it was approached, being less firmly constructed, were more liable to give way under superimposing weight; and to prevent so untoward a catastrophe, they were entirely filled inside with earth, proved by the state of absolute obstruction in which they are found, and the absence of an opening of any kind at their extremity.

“Thus the progress of the labour explains itself. If now we look into the processes with which the stones were made ready for use, we shall trace analogies between the methods of the Lydians and those of the Greeks, which cannot assuredly be considered as fortuitous. The blocks are prepared exactly as those of Hellenic monuments of the best epoch. When time

failed for dressing beforehand those intended to line the walls, we find grooves around the unfinished units to guide the stone-cutter in the completion of his work (Fig. 176)—a mode of execution likewise followed in the Propylæa at Athens. But when the blocks were put in place ready cut, near the salient angles and along the edges, seams in relief have been reserved to prevent the effect of violent contact (Figs. 168, 169, 172). Very similar precautions were resorted to at Segesta, in Sicily, in placing the architrave. As with the Greeks, here also, the covering slabs of the chambers are horizontally placed; and the result is a ceiling instead of a vault. When the builder feared to see the slab of his ceilings break under downward weight, he reduced the span by approaching the two supporting walls (Fig. 171). In this way the Greeks perpetually ensured solidity to their platbands; the lintels of their doorways are laid upon piers whose intervening space is less towards the top than at the base.”¹

A curious detail will be observed: wherever the masonry in the galleries is of small units, we find them neither cemented nor set up dry, but imbedded in soft mud; the mark left by the trowel for smoothing it down is still to be seen. No example has been traced of so primitive a mode in the monumental constructions of antiquity.

All the precious objects deposited in these tombs have disappeared. M. Choisy collected on the site chips of resinous wood, probably remains of ancient coffins, along with iron clamps that served to hold them together; fragments of pottery, bits of a fine alabaster vase with an elongated profile, and finally stone beds upon which the Lydians laid their dead. All these couches were cast out of the vaults when the excavations took place; but from the pieces that were then collected, it has been possible to restore a whole bed (Fig. 178). The funereal couch was upheld by two supports of unsquared stone, the upper face of which was slightly sunk, in

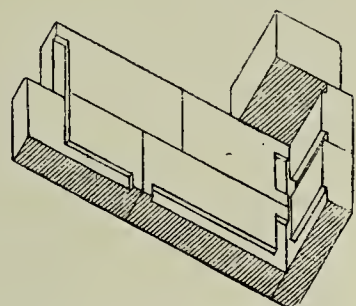

FIG. 176.—Aspect of facing. Choisy, Fig. 11.

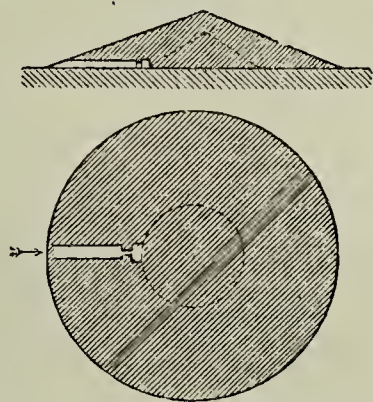

FIG. 177.—Tumulus. Plan and section. *Ibid.*, Fig. 12.

¹ CHOISY, *Note*, pp. 76, 77.

imitation of the depression made by the body upon a mattress, and at either end the corner bulged out with a hollow in the

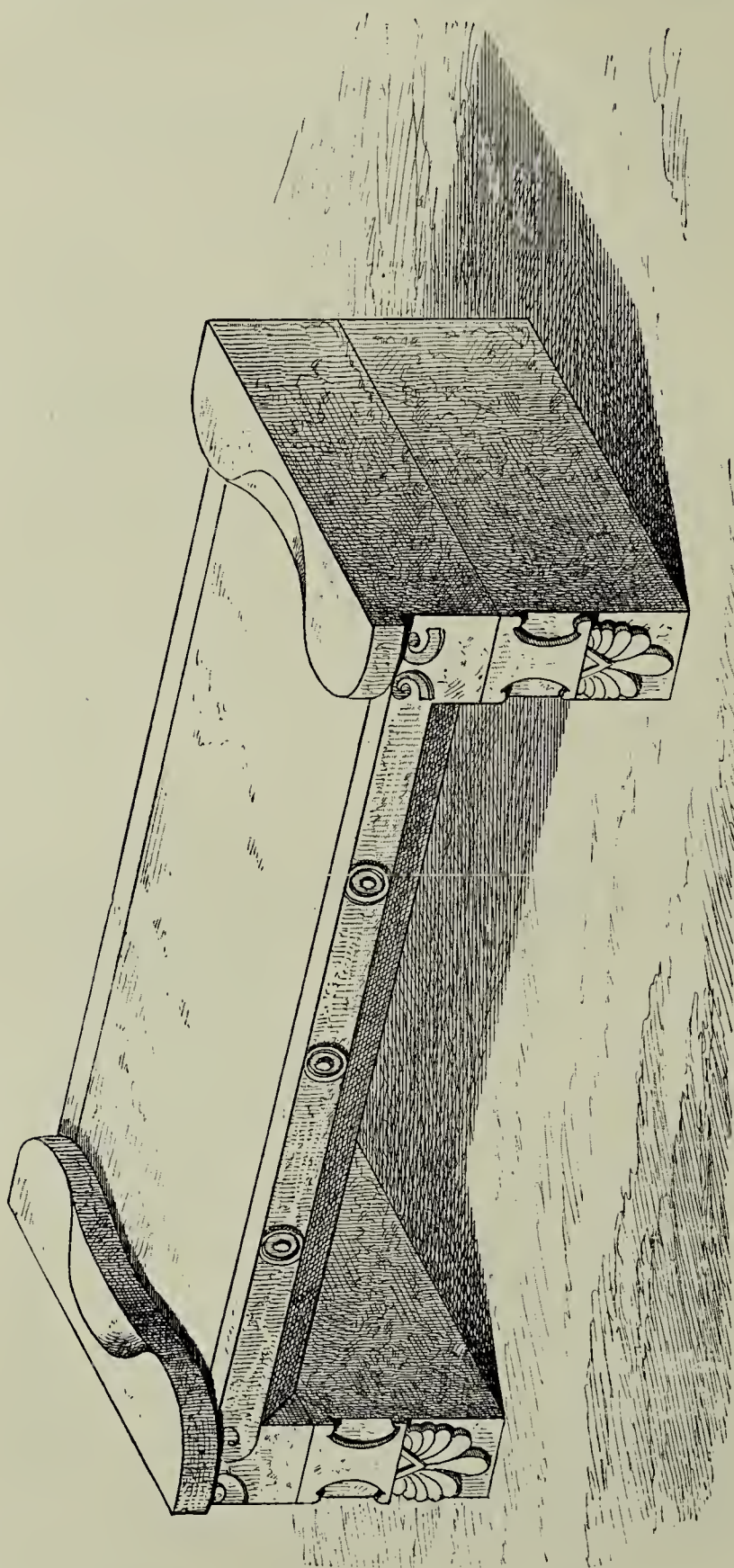

FIG. 178.—Funereal bed. Choisy, Fig. 13.

middle, as would a pillow upon which the head has rested. In the front face of the stone bed is an ornament in the shape of a patera; to judge from the thinness, as well as from the palmette design decorating them, the feet carved on the anterior face of the supporting slabs would appear to be copied from a bronze couch. In many of these beds, when there was not time enough to chisel the stone, the painter's brush was used in the decoration. Vestiges of colour, red and green, are distinguishable on another couch, a transverse section of which is given in

Fig. 179. Thus the Greek key along the edge of the pillow was merely painted; so were the stars decorating the lateral face

of the mattress, the "rays" of which are partly green and partly red. The drawing of these stars is inaccurate and bad, and indications of hurry, we might say precipitation, are patent everywhere. But all the same, the design and ornament of this piece of furniture bespeak the frank and firm treatment of a late period. On the other hand, no tombs with Greek inscriptions have been discovered in this plain. The Hellenicized Sardes of the Achæmenidæ, of the Seleucidæ, and of the kings of Pergamus, had her cemeteries closer at hand. In Bin Tepe we have the ancient Lydian necropolis, that in which the heads of the great families had wished to repose beside their kings; but there are no data to warrant the supposition that, as time went on, people continued to be buried there. Consequently we may regard these tombs as anterior to the defeat of Cræsus; the more recent would date from the first half of the sixth

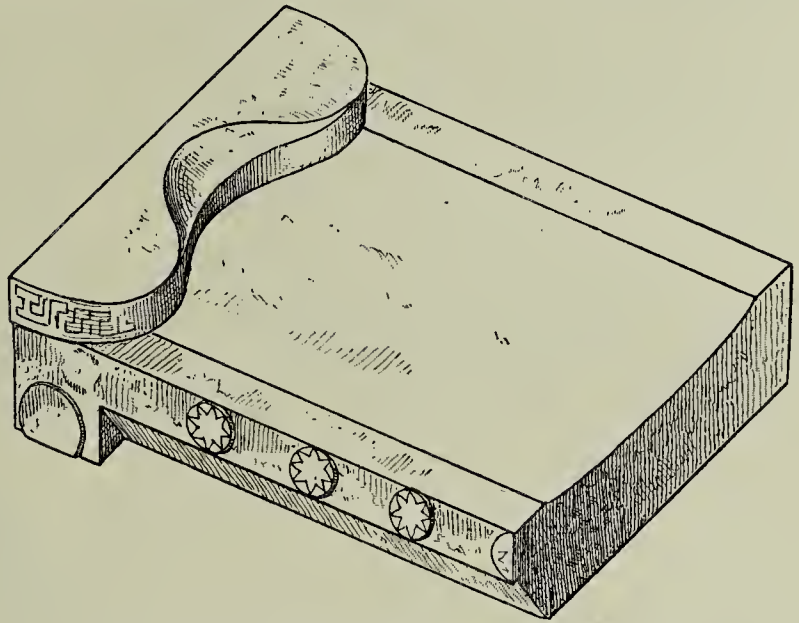

FIG. 179.—Funereal bed, with painted ornaments.
Choisy, Plate XIII. A.

century B.C. This hypothesis is not belied by the style of the mouldings, or the aspect of the many fragments picked up during the excavations in this field of the dead.

The tumuli situate near Lake Coloæ were not the sole instances to be found in this district. A fragmentary text of Hipponax, unfortunately very much corrupted, describes a number of similar monuments, which the traveller met with on the road to Smyrna leading across the Lydian territory.¹ If we suppose the above highway to be that which ran from Ephesus to Smyrna (Hipponax was a native of the former city), we might recognize as one of the tumuli specified by the poet that to which a great expert in matters relating to this region has drawn the attention of the learned world.² It stands about two miles northward of Ephesus, in the

¹ Hipponax, Frag. 15 (BERGK, *Pœtæ lyrici Græci*, tom. iii).

² G. WEBER, *Tumulus et hiéron de Bélèvi, sur l'ancienne route d'Éphèse à Sardes*,

valley of the Cayster, near a rocky hillock in which was excavated a primitive sanctuary; apparently replaced under the Roman dominion by an Ionic temple, the remains of which strew the ground. Some hundred and twenty yards from these ruins, in a westward direction, rises a hill whose top was transformed into a tumulus, which rules the valley. The result was obtained

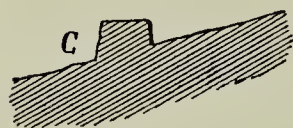

FIG. 180.—Tumulus at Belevi. Notch in rock. Weber, Plate I. Fig. 2.

was to build a retaining wall at the foot of the hill, which effectually prevented the slipping of loose soil over the talus and preserved the integrity of the mound. The masonry of this wall is more regular than that of the tombs around Sardes. It is made up of alternating courses of varying height, which bring to mind what is called Hellenic stone-work. The blocks, set out without mortar, are “bossed” and show careful execution. An ingenious contrivance was resorted to in order to guard against the sliding of stones consequent upon a lateral thrust (Fig. 180). At twenty-five centimetres from the external border of the unit,



FIG. 181.—General view of tumulus. Weber, Plate I. Fig. 2.

was cut a groove or notch eleven centimetres deep, which exactly fitted a seam in relief cut in the upper stone; so that it was able to oppose the utmost resistance to pressure acting from the apex of the tumulus towards the circumference. The best view of the whole tumulus and of the substructure is obtained from the south side (Fig. 181), where stood the entrance (Fig. 182, o). This, to

8vo, 16 pages and two plates. The village is marked in Kiepert's map under the slightly changed name of Beledi.

judge from the arrangement of the wall, was not likely to be distinguished by any architectural devices. At the top of the mound, which is slightly rounded, a few blocks of limestone are sprinkled about; remains, it may be, of a crowning respecting which no opinion can be advanced.

The action of rain water has nearly blocked up the opening of the passage, which can only be entered by crawling on all fours (Fig. 183). It is roofed over with large slabs of limestone, and is very low to about eight metres from the threshold, when it suddenly slopes upwards to a height of close upon two metres, to sink very gradually again. The gallery leads to a series of chambers, whose level is sunk one metre (see plan, Fig. 184). The first is little more than a widening of the passage. Its walls, as those of the other two apartments,

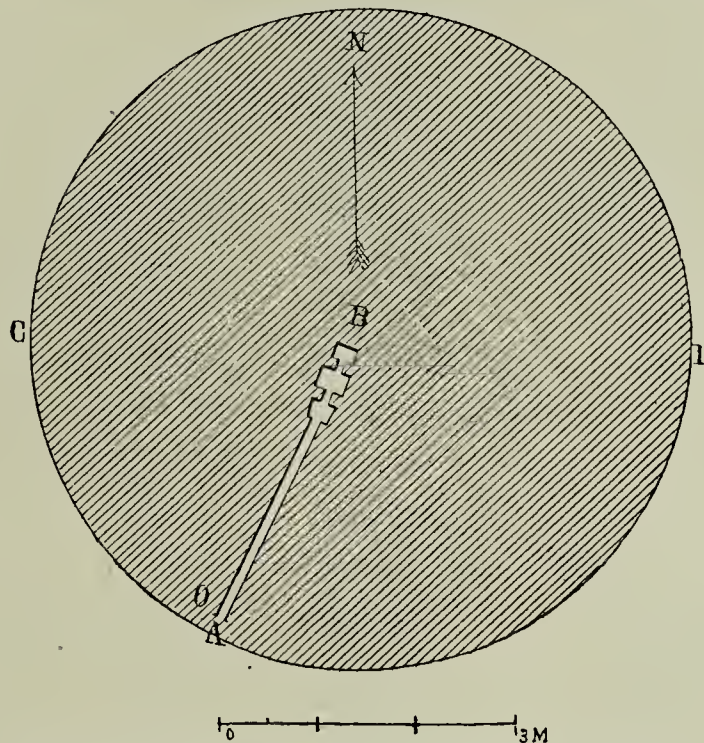

FIG. 182.—Plan of tumulus. Weber, Plate I. Fig. 3.

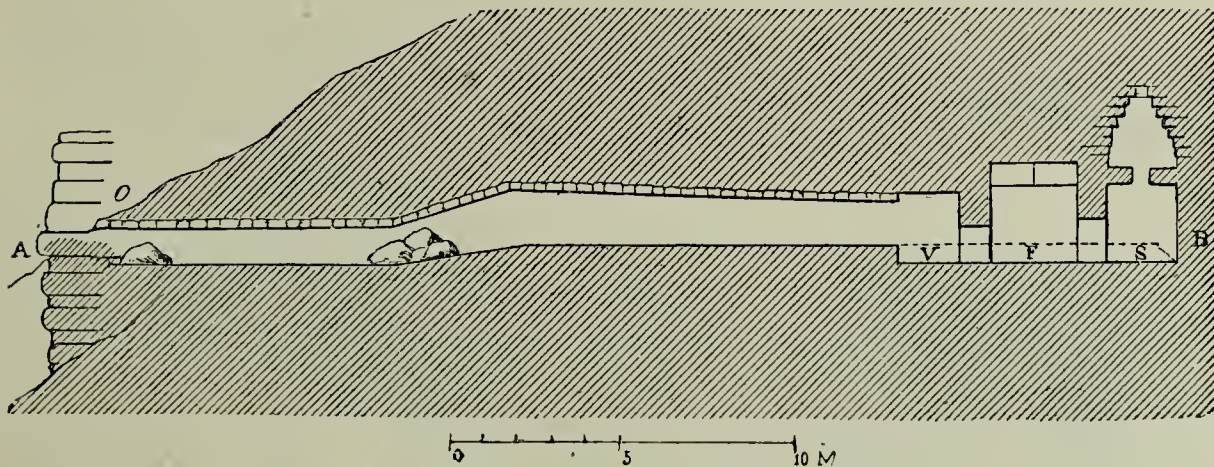

FIG. 183.—Longitudinal section. Weber, Plate I. Fig. 3.

are made of stones of large calibre, smoothed over with care. The next room is 2 m. 50 c. by 2 m. 70 c. wide. Here the builder found the space to be covered much too large for the materials at hand; to get over the difficulty he put triangular

blocks at the four corners of the chambers, thus making a rectangle within a rectangle and reducing the opening. The only

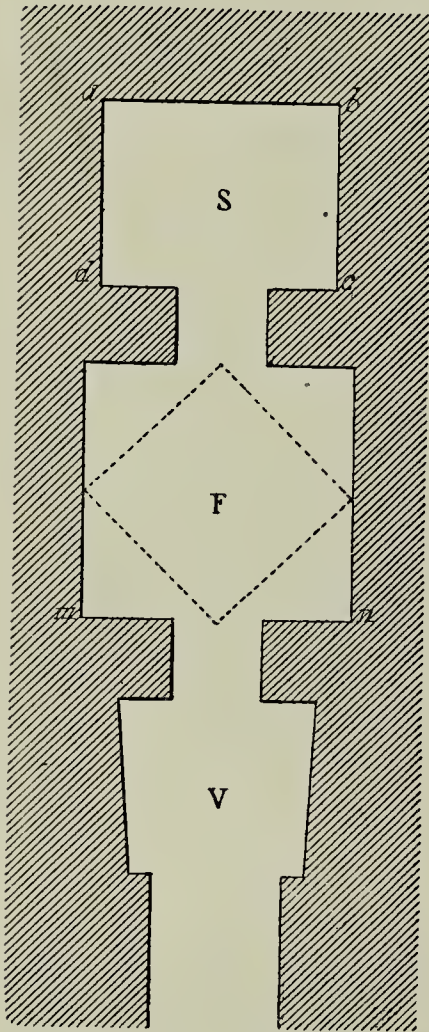

FIG. 184.—Plan of chambers.
Weber, Plate I. Fig. 7.

attempt to decorate the bare surface of the walls is found in a tiny cornice, a simple quarter round, which surrounds the roof of the vault (Fig. 185).

The eastern and western walls are straight, as in the Tantaleis tomb of Smyrna (Fig. 186). Springing from the other walls, at a height of 1 m. 55 c., is a corbel arch, made of two courses of four blocks, two on each side (Fig. 187). Fearing that the system would yield under the weight of accumulated earth, the builder placed a discharging chamber above the roof, which is entered by an opening pierced in the vault. The material employed in the building of this loft was not prepared with the same care as in the other sections of the structure; nevertheless the end aimed at was obtained by setting the courses slightly in advance one of the other, thus narrowing by degrees a space of more than two metres in height.

The fact that the tomb has been opened for centuries, explains the absence of a funereal bed and of any fragment by which it might be approximately dated. The explorer who has described it insists

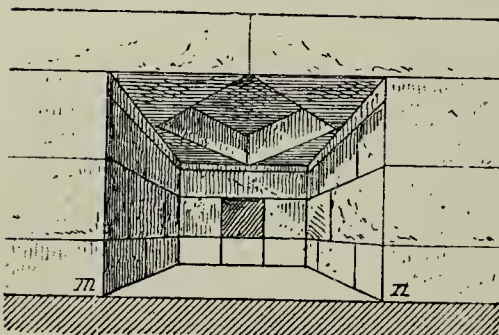

FIG. 185.—Perspective view of second chamber, F. *Ibid.*, Fig. 5.

on the regularity of the material employed, and is led to infer from it that the tomb was erected under Greek influence, at an age when the taste was felt for a better and more perfect art than could have been known to the contemporaries of Alyattes and Cræsus. The drawings he has furnished are inadequate,

however, and on too small a scale to permit us properly to judge of the difference between the two sets of monuments.

But we may remark that regular courses are the rule about the walls of the tumuli at Bin Tepe; whilst tall and low courses, which are pointed out as characteristic of Hellenic masonry, are seen in the Tantaleis tomb (Figs. 16, 17). The method is identical in both; and if in this solitary instance the execution is better, the fact may be due to its having been erected at greater leisure. It is just possible, therefore, that the tomb under discussion may be anterior to the Persian rule; as it is quite as likely to have been constructed at a later age, for a wealthy Lydian, a tyrant of Ephesus, in imitation of the old royal tombs. This type of burial is very similar to that of the tumuli of the Troad, within which Achilles and Ajax were supposed to rest; it brought to mind the heroes of the *Iliad*, along with the kings of the old local dynasties, Gyges and Crœsus, whose names stirred and filled the imagination of men with legends no less remarkable than those connected with the epos. The effect of these reminiscences and the ideas they brought in their train was seen in the funereal architecture, which here and there harked back to ancestral models, as late as the third century of our era,¹ in the full swing of Alexandrian culture. About the Belevi monument, however, are data that make it unnecessary, nay forbid, our travelling so far down; instanced in the awkward expedients resorted to for covering the two main chambers, which betray the gropings of inexperience and unskilfulness. What seems most probable is that the tomb is not much later than those around Sardes, and that, like them, it was allied to the traditions still current in the country at the time of its erection. Hence we shall not greatly err in ascribing it to the latter half of the sixth century B.C. This it is that has led us to put it to the account of Lydian art.

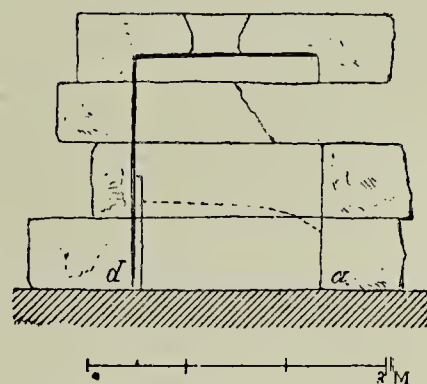

FIG. 186.—Third chamber, s, section through a, d. Weber, Plate I. Fig. 6.

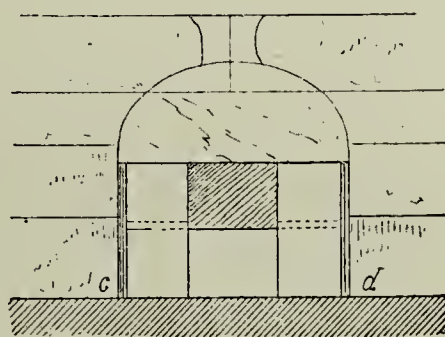

FIG. 187.—Third chamber, s; section through c, d.

¹ See *Beitraege zur Geschichte und Topographie Kleinasiens*, Curtius, p. 53, note by Adler; *Klaessische Baudenkmale zu Pergamon*, pp. 55, 56, with drawings from Plate III.

Considered as a whole, the dispositions of the tombs we have just surveyed belong to the type encountered everywhere in the Smyrna necropolis. Nevertheless, when placed side by side and looked into critically, slight differences become apparent. Thus the internal arrangement of the Tantaleis tumulus is a dry stone-work of small units (Figs. 14, 15). Around Sardes the pebbles are replaced by a system of radiating and concentric walls, and superimposed layers of earth and concrete rammed in as tight as possible. In Lydia the base of the tumulus is a truncated cone; it is barrel-shaped at Smyrna. Here, too, the sepulchral chambers are found in the centre of the mound; but at Belevi, in the royal necropolis of the Mermnadæ, they never occupy that situation. The resemblances between the two groups of funereal edifices are sufficiently marked to justify the conclusion that they are the work of one race, a race which, on the slopes of Sipylus, as at the foot of Tmolus, were faithful to habits taken up, perhaps, in their cradle-land, and brought with them from Europe to Asia. But different hands worked at the two sets of buildings. On the other hand, differences are striking enough in the arrangement of the plan as well as the processes of execution, to induce the belief that they were due to two people and two different ages. This hypothesis is in harmony with our knowledge of the history of the Lydians and the Phrygians, their original affinities, and the difference of their ultimate fate.

Funereal architecture is the only branch of that noble art which has left traces on the Lydian soil. On many a point of Lydia were sanctuaries, whose foundation and repute led back to the far-off days of national independence. Such would be the temple of Cybele at Sardes, and that of Artemis Gygæa, hard by the lake from which she was called. It is highly probable that here, as at Ephesus, the name of Artemis covers that other name of Anahith, so soon forgotten, or one or other of those goddesses who, in the eyes of Asiatics, personified the creative power of nature—the power that calls forth beings into existence, to destroy them when their hour is come to make way for new generations. The site of both edifices is thought to have been identified; what remains, however, or rather all that is found above ground, belongs to very late reconstructions. The two Ionic columns still standing on the right bank of the Pactolus, and fragments of an entablature lying on the ground beside them, were part of an

edifice certainly not older than the Seleucidæ,¹ perhaps even later (Fig. 154).

Of the temple of Artemis Gygæa, or Colonæ, only three Doric columns are left, along with remains of a frieze on which appears a lion's head, and an archer with a pointed cap. Details are wanting; but the very fact that forms belonging to one of the canonic orders have been employed suffices to show that here also we have a building Hellenic in character.² Examinations made at this point might yield interesting results; for the temple in the day of Strabo was one of the most honoured in Asia, and we know that the veneration which attaches to sacred places is in direct proportion to the antiquity ascribed thereto.³ Marble was used in rebuilding these temples, but we have proofs that bricks, in the reigns of the Lydian kings, were likewise employed in edifices of great size. Under the action of air and water, formations such as gneiss, the main constituent of the Tmolus mass, crumble away and furnish an excellent clay. The fact that Lydia in old days gave her name to a special type of bricks suggests the notion that they were manufactured on a large scale for exportation. Thus in Italy clay units one foot and a half by one in width were called "Lydian bricks."⁴ Nor have bricks ever gone out of fashion in Lydia; their usage is universal at the present day for house covering. The excellent quality of the native clay led Lydian builders to apply it to ornamental purposes, in the same way as the Chaldæan masons had done before them; but it never entered into the scheme of the Greek architect. A German traveller⁵ mentions having seen, on the right bank of the Pactoclus at Sardes, colossal drums in terra-cotta lying on the ground amidst accumulated rubbish. In the days of Augustus there was here an old brick building called *the Palace of Cræsus*,

¹ CURTIUS, *Beitræge*, pp. 87, 88, Adler. STARK (*Nach dem griechischen Orient*, p. 394) shows very forcibly that it by no means follows that the two Ionic columns represent the temple of Cybele, a temple which, according to Herodotus, disappeared in the general conflagration of Sardes. We have no information as to the site of this temple, and a city of the importance and magnitude of Sardes must have had other sanctuaries, notably in the Græco-Roman period.

² The only data we possess in regard to these ruins were borrowed by E. Curtius from the notes of Spiegelthal (*Artemis Gygæia, und die Lydischen Fuerstengraeber*, *Archæ. Zeitung*, 1853, pp. 148-161, more particularly p. 152).

³ Strabo, XIII. iv. 5.

⁴ PLINY, *Hist. Natur.*, xxxv. 49.

⁵ GREGOROVIVS, *Kleine Schriften*, tom. i. p. 15.

within which the elders withdrew themselves on market days, to avoid the turmoil and bustle going on around them. To have fulfilled the condition of a place of rest, the house must have stood in the lower city ; for requiring old men to climb up the high and steep hill upon which the citadel was perched, would have been anything but a relief to their shaky aged limbs. The foundations at least of this important edifice must still exist, and would in all likelihood be found on one of the platforms staged between the flat level and the precipices terminating the Acropolis on the north.

The fact that the palace lasted more than five centuries, is strong evidence that it was built of bricks baked in the kiln. Raw bricks were largely employed in the building of private houses ; these, if we are to believe Herodotus, 500 B.C., were nothing more than huts thatched with reeds ; and even in those instances when the walls were made of brick, the roof was invariably thatched ;¹ hence it was that one of these ephemeral huts having been set on fire, the flames soon spread to the whole town and brought about its destruction. Until the Persian conquest (divided from the Ionian rebellion by a little over forty years), buildings of great importance, as the tomb of Alyattes and the palace, were only erected by the kings and grandees of Lydia ; so that the town, which was open, had the appearance of a huge village.

SCULPTURE AND NUMISMATICS.

If not a single sculptured work remains which may be attributed to the Lydians with any reasonableness, this is to be accounted for in their marked preference for built tombs, those in which the vault is hidden away in the depths of the tumulus. Had they, like the Phrygians and the Paphlagonians, hollowed the sepulchres of their kings in the living rock, bas-reliefs would have been preserved about Tmolus and the neighbouring hills, akin to those we have met on the central plateau. But rock-sculptures are rare within the Lydian territory, and, to judge from their execution, they clearly belong to the time of the Roman dominion.²

¹ VITRUVIUS, *De Architectura*, ii. 10 ; PLINY, *loc. cit.*, xxxv. 49.

² In *Voyage Archéologique* of Le Bas, Plate LV., "Itinéraire," are reproduced three bas-reliefs, the originals of which are found at Ammam, in the Upper Hermus,

If under the circumstances we could not expect to see figures flung athwart the face of the stony cliff, we had hopes that the tombs of Lydia would yield small objects, such as bronzes and terra-cottas; those that have been opened, however, have revealed nothing of the kind, whilst the small figures sold by dealers of curios at Constantinople and Smyrna are almost always of uncertain origin. Reference was made a little while ago to a quadrangular stone covered with writing on three of its faces,¹ which was discovered at Ak-Hissar (ancient Thyatira). On the fourth face was incised a man's figure, whose head and bust are completely obliterated; the legs, which are inwardly bent and wide apart, are alone preserved,² so that little is to be made out of the monument.

Coins are the only instances left to us from which to obtain some notion of the way the Lydians understood and rendered the human form. The pieces in electrum, divided into two different systems, are the oldest creations of the coiner's art in Lydia; both of which had their origin in Mesopotamia. In the one which is generally called Babylonian, the unit of weight is a mine of 505 grammes, divisible into 60 parts of 8 grammes 415 c. each; in the other, known as Græco-Asiatic or Phœnician, the mine is equal to 1010 grammes, and its sixtieth part is 16 grammes 13 c. The lighter mine would seem to have been introduced in the interior of Asia Minor, by the Syro-Cappadocians and the Phrygians; whilst the heavier mine was carried to the coasts and the islands of the Ægean, and thence to continental Greece, by the Phœnicians. We do not propose entering into details as to the expedients which followed the invention of coinage, and which were taken up by the Lydians and Ionians in order to fix the relation between the three precious metals employed in succession in the issue of money. Any one interested in the subject should consult a standard work in which are duly set forth the different cuts that were adopted for each of the metals, and the simultaneous introduction of the sexagesimal

north-east of Kulah, on the Ghedissū; that is to say, in the district formerly called Mæonia. The sculptures are descriptive of religious scenes connected with the cultus of Atys. In the one he is seen under a pine, a tree sacred to him; in the next he is surrounded by a pack of hounds; whilst in the third, he is borne in the arms of his worshippers, who are about to lay him in the tomb.

¹ *History of Art*, tom. v. p. 242, note 1.

² A squeeze due to M. S. Reinach has been deposited in the Bibliothèque de l'Institut.

and decimal division, by means of which the end aimed at was more easily reached.¹ The important thing to be remembered is the fact that the lighter pieces were struck at Sardes to facilitate the caravan traffic carried on between the Euphrates valley and Lydia; whilst the larger, heavier mine would seem to have been more particularly employed in the commercial transactions of the Mermnadæ with the Greeks of the seaboard. The interest these pieces have in our estimation does not reside in their specific weight, but in their form and the image impressed thereon; we

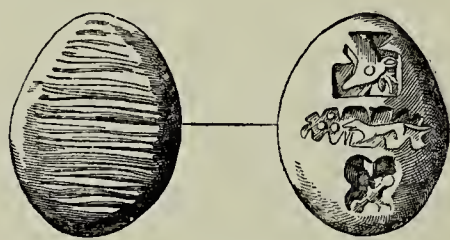

FIG. 188.—Lydian coin. Electrum.
British Museum.

study them as monuments of the arts of design. The moneys attributed to the age of Gyges and Ardys are all in electrum. On one side are markings or striæ, but no impression made with the die; on the reverse, three deep indentations, oblong in the middle, square on either side. In these hol-

lows are symbols in relief, sometimes very indistinct. The most curious is seen in Fig. 188, exhibiting a running fox within the narrow slit cut right across the piece. Here and there, despite the smallness of the image, the animal is distinguishable and easily recognized;² in the majority of cases, however, it is guesswork rather than vision. On the smaller ingots, as the half and other fractions of the stater, the markings of the punches are more or less rude and irregular.

The Greeks of Miletus, Ephesus, Cymæ, and Phocæa, who had in very early days adopted the electrum, then the gold coinage of Lydia, showed no less alacrity in making their own the new invention, the advantages of which were patent to all. But they soon improved upon the medals they had borrowed from the Lydians, and made a great step onward when they took the image out of the bed in which it lay in shadow, and set it up in the light of day, on one of the faces. To this progressive stage already belongs a specimen attributed with a great degree of probability to

¹ See FR. LENORMANT, *Monnaies royales de la Lydie*, pp. 184-196; BARCLAY V. HEAD, *Coinage of Lydia and Persia*, pp. 1-7; *Hist. Num.*, "Introduction," pp. xxviii.-xxxvi.

² Some have denied the existence of the fox in the situation referred to in the text; but it is plain enough in Fig. 188, which was drawn by M. St. Elme Gautier, from an impression kindly forwarded to us by Mr. Barclay V. Head of the British Museum.

Sandyattes or Alyattes (Fig. 189). On one side are seen the foreparts of a lion and a bull, back to back, or rather neck to neck;¹ on the other, a square hollow produced by the relief of some hard substance, upon which was placed the blank piece of metal to be struck by the hammer. At the first blows the pattern on the die enters the metal and prevents it moving out of place. We propose to assign the same origin and date to another stater, bear-

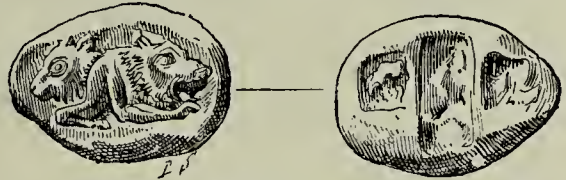

FIG. 189.—Lydian coin. Electrum. Cabinet des Médailles.

ing the head of a lion turned to the left, with open mouth and protruding tongue (Fig. 190). The reverse of certain pieces, with a lion couchant on the obverse, and head turned away to the left, is like that of the earliest coins ever issued, proving that old puncheons were used over again (Fig. 191).²

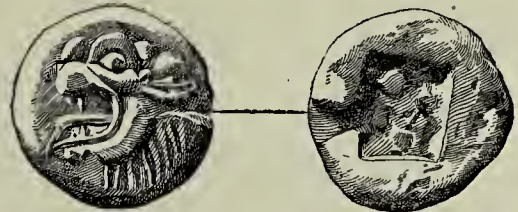

FIG. 190.—Lydian coin. Electrum. British Museum.

As stated, Crœsus appears in history as a monetary reformer. Now, the Greek cities of Miletus, Ephesus, and Phocœa began to issue staters and fractions of the same, in pure gold, as early as the reigns of Alyattes and Sandyattes, the father and grandfather of Crœsus. In the lifetime of Alyattes, Crœsus was made governor of Mysia, and was thus for years a near neighbour of Phocœa, a circumstance calculated to bring home to him the many advantages of the new coinage, whose standard was more closely defined than that of the electrum pieces struck by his predecessors. On his ascending the throne, therefore, he ceased to coin electrum, and put in circulation new pieces of gold and silver. He is fathered with two gold staters, of varying weight,



FIG. 191.—Lydian coin. Electrum. British Museum.

¹ The images are so blurred as to challenge the question whether we should not rather see in them bulls; but arguing from the pieces ascribed to Crœsus, in which the lion and the bull are quite distinguishable, has led to the conclusion that in this instance also the coiner meant to depict the two inimical animals.

² It is uncertain whether the coins in question should be ascribed to Sardes or Miletus (BARCLAY V. HEAD, *Hist. Numorum*, p. 545). The balance is in favour of Sardes from the fact that the fox appears on them, an image not seen on the later pieces of Miletus.

corresponding with the two systems current in Lydia proper and the neighbouring provinces. As to the silver stater issued by this prince, it was the tenth part of his gold stater. Thanks to these wise measures, Lydian pieces were readily accepted, not only throughout the empire, from the Halys to the Ægean, but outside the frontiers as well; whilst in every market of the seaboard they more than held their own against the coinage struck by the Ionian cities.

No matter the metal of which the coins were made, whether large or small, all that came out of the royal mint at Sardes have one uniform type: the foreparts of a lion and a bull face to face, the former with open mouth, the latter with protruding horn (Fig. 192); on the reverse, two hollow squares, made by two dies with rude irregular surface.



FIG. 192.—Gold Lydian coin.
Cabinet des Médailles.

Of the types that appear on these coins, the lion and the group made up of the lion and the bull, alone belong to the “common properties” of Oriental art. The lion seems to have held in the national myths of Lydia as large a place as in Cappadocia and Phrygia.¹ As to the manipulation of all these pieces, it is in perfect harmony with the origin and the date we ascribe to them; the forms of the animal have the somewhat rigid precision which we found everywhere to be the characteristics of analogous works, from the palaces of Assyria to the Phrygian necropoles. It is not to be denied that the Lydian staters, with types on relief, have little to differentiate them from those that were struck nearly at the same time by the cities of the seaboard; a resemblance, than which no more likely hypothesis can be adduced than that Ionian engravers were called to Sardes by Alyattes and Cræsus. In the sixth century B.C., Ephesus and Miletus would not have condescended to take their types from people they called *Barbarians*; the art of Ionia was too far advanced; it moved from progress to progress with too bold and independent a mien, to have permitted her to look beyond her frontiers for such borrowings as these. On the other hand, at that time Greek sculpture, in its representation of the animal form, notably the lion, was still archaic and a slavish imitator of Oriental models; it needed no effort nor shifting of its lines to enable it to turn out images for the Mermnadæ in perfect

¹ See *Hist. of Art*, tom. v. p. 262.

accord with those with which the country was familiar. One would be tempted, however, to exclude from coins of this kind that with a lion's head (Fig. 190), where details are imbued with a certain degree of heaviness and exaggeration, that remind one of the workmanship of the Phrygian necropolis (Figs. 64, 120).

INDUSTRIAL ARTS.

The capital potter's clay that made the fortune of the Lydian bricks was equally fitted to taking any form the potter at his wheel chose to impress upon it. Ceramic industry, to take the word in its widest sense, seems to have been very flourishing in Lydia. Certain types of drinking-cups were said to be of Lydian invention.¹ The fragments of vases collected by Spiegelthal in the mortuary chamber of Alyattes, including remains of flasks in Oriental alabaster, do not belong to the high-class objects above mentioned, but to the common everyday earthenware (Fig. 193). Nevertheless, not one of these pieces, even the plainest without a trace of ornament (Figs. 194, 195), but testifies to advanced technique. The paste, when broken, is light red and of very fine texture; it has been well potted, and so nicely turned on the wheel as to have yielded a contour of the utmost regularity.²

Parallel bands running round the body are the sole decoration of the most carefully fashioned vases (Fig. 196). On another fragment, dots arranged in circles appear between the bands (Fig. 198); whilst concentric circles are exhibited inside the bowls (Fig. 199). A drinking cup, of which only a tantalizing small piece remains, was furnished with a handle whose design and attachment were not void of elegance (Fig. 197). Variety, whether of tone or designs, is sadly to seek. The ornamentist used little more than whites or yellow ochres or both combined, of varying depth, which he opposed to dull browns. Precisely similar in character are a



FIG. 193. — Alabastron. Third of actual size. Von Olfers, Plate V. Fig. 10.

¹ Critias, cited by Athenæus, x. p. 432, D. It is regrettable that the passage should have been tampered with.

² VON OLFERS, *Ueber die Lydischen Königsgräber bei Sardes*, pp. 549, 550.

few tiny bits picked up in another tumulus of this same necropolis (Figs. 200-202).¹ The largest of these (Fig. 200) has beautiful black lines on a field of reddish yellow. If, as far as we can judge from these much too rare and minute fragments, the ceramists of the age of Alyattes were thoroughly masters



FIG. 194.—Vase found in tomb of Alyattes, Third of actual size. Von Olfers, Plate V. Fig. 7.



FIG. 195.—Vase found in tomb of Alyattes. Third of actual size. *Ibid.*

of the secrets of their art, it must be confessed that they were deficient in imagination. It was not at their school that the Greek potters of the maritime cities could learn to paint figures on their vases. No terra-cotta statuettes or small bronze figures have been found in Lydia up to the moment we write; the soil



FIGS. 196-199.—Fragments of vases found in tomb of Alyattes. Third of actual size. Von Olfers, Plate V. Figs. 2, 3, 6.

of Sardes still awaits to be stirred from its very depths. Professor Sayce, who explored its ruins, "satisfied himself that the remains of the old Lydian city in the valley of the Pactolus lie at a depth of more than forty feet, both below and above the temple of

¹ In regard to the vase-fragments figured in next page, the result of Dennis's excavations, see the critical account from the pen of Cecil Smith (*Classical Review*, 1887, tom. i. p. 82).

Cybele.”¹ It is matter for surprise that excavations offering no difficulty should not yet have been made.

In that Lydia whose wealth was the admiration of her neighbours, the art of working metals cannot but have kept pace with

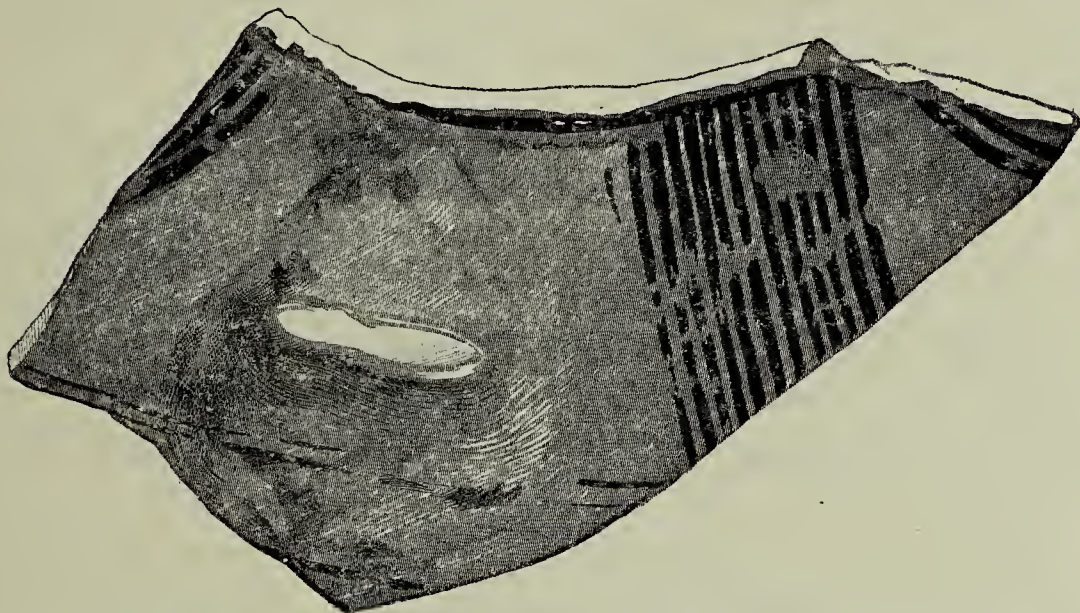

FIG. 200.—Fragment of vase from Bin Tepe. Third of actual size. British Museum.

ceramic industry. Within a region where gold and silver were found in abundance, trinkets of the precious metals must have been made and worn. As samples of Lydian jewellery should be



FIGS. 201, 202.—Fragments of vases from Bin Tepe. Actual size.

mentioned the remarkably fine personal ornaments in pure gold, now in the Louvre (Figs. 203–208). They were found in the vicinity of Aidin (ancient Tralles), *e.g.* on the boundary line between Lydia and Caria.² Professor Ramsay, in one of his many visits to the

¹ SAYCE, *Notes from Journeys in the Troad and Lydia*, p. 86 (*Hell. Studies*, 1880).

² A. DUMONT, “Note sur des bijoux trouvés en Lydie” (*Bulletin de correspondance hellénique*, 1879, pp. 129, 130). The trinkets in question are fully described in the

country, was told that the trinkets in question had been taken out of a tumulus—a not improbable statement; for if nothing of the kind has been discovered in the tomb of Alyattes, the fact is due to its having been rifled in antiquity; whilst the score or so of tumuli that have been recently opened in Southern Caria have yielded a variety of gold objects, jewels, tubes, pieces that were sewn on dresses, spirals, rings, fibulæ.¹

“The main piece is a thick gold slab or plaque, shaped into a semicircle; a horizontal tube, held in place by four rings, divides

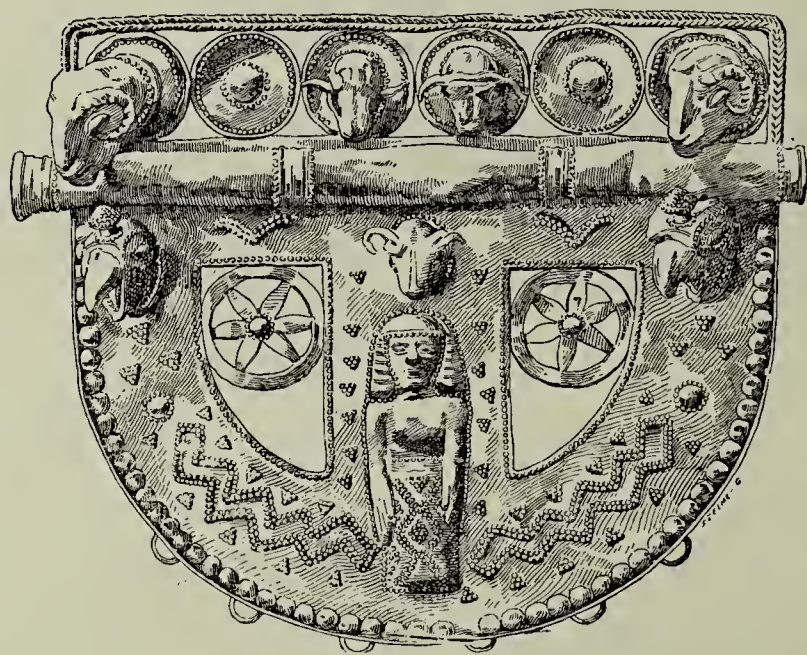

FIG. 203.—Lydian plaque. Height, 68 c.; length, 77 c. Louvre. Drawn by St. Elme Gautier.

the field into two unequal sections; above is a narrow band whose space is entirely taken up by a row of discs, ornamented, like the rings, with a beaded edge (Fig. 203). A double twist surrounds the sides and the top of the oblong panel. Diminutive bulls' heads stamped on gold leaf appear in the two central discs; a navel is the only decoration of Nos. 2 and 5, whilst the remaining ones at either end exhibit two huge rams' heads. Below the cylinder, towards the top of the semicircle, are three heads of different animals; a bull in the centre, flanked by hawks of considerable size. Each of these discs has a central hole into which is let the neck of the animal. The way it was secured at the back was not by soldering, but by turning down the end piece (see Fig. 204). Below, in the middle of the slab, is a small female figure in slight relief, whose hieratic pose, dress, and hair arranged

Catalogue des objets d'art antiques, terres cuites, bijoux, verrerie, made by M. Froehner for the sale of the Hoffman collection (May 26, 27, 1886). The letterpress is accompanied by a capital coloured plate, 4to, 1886, Plate XX. Its only drawback is that the objects appear too fresh and new.

¹ PATON, *Excavations in Caria*, pp. 68, 69 (*Journal of Hell. Studies*, 1887).

in true Egyptian fashion seem to indicate a goddess. The arms, which are bare, hang close to her sides; she is nude down to the waist; from it the body is wrapped in drapery entirely covered with a beaded pattern, of great fineness and



FIG. 204.—Back view of Lydian trinkets. *Bulletin de correspondance hellénique*, 1882, Plate V.

delicacy, made up of lozenges and triangles. A double row of beaded chevrons, and a pearl border running round the edge of the semicircle, complete this rich ornamentation. Nor should the six loops fixed at the back, below the lower rim, destined to receive pendants, go unnoticed.”¹

The next is an oblong slab, likewise topped by a tube, with

¹ FROEHNER, *Catalogue*, pp. 49, 50.

two masks, very similar in style to the goddess, separated by a rosette encircled within a narrow band (Fig. 205); above the tube,

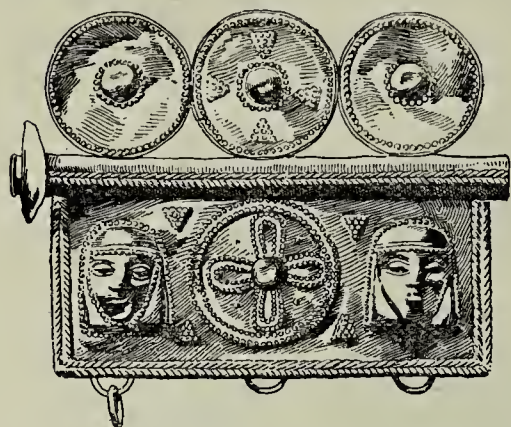

FIG. 205.—Lydian trinket. Height, 35 c.; length, 89 c. Louvre. Drawn by St. Elme Gautier.

are three discs with central navel, and granulated work. Many of these ornaments of double gold leaf have a vertical tube; they are simpler in plan and execution than the preceding, and are cut in the shape of a double-edged axe (Fig. 206). The largest specimens have a pearl border, and the crescents terminate in a fluted knob or button, one on each side. More pearls are arranged cross-wise in the field. In another

plaque, precisely similar but smaller, the pearls are replaced by filigree work. Other two discs are juxtaposed and surmounted

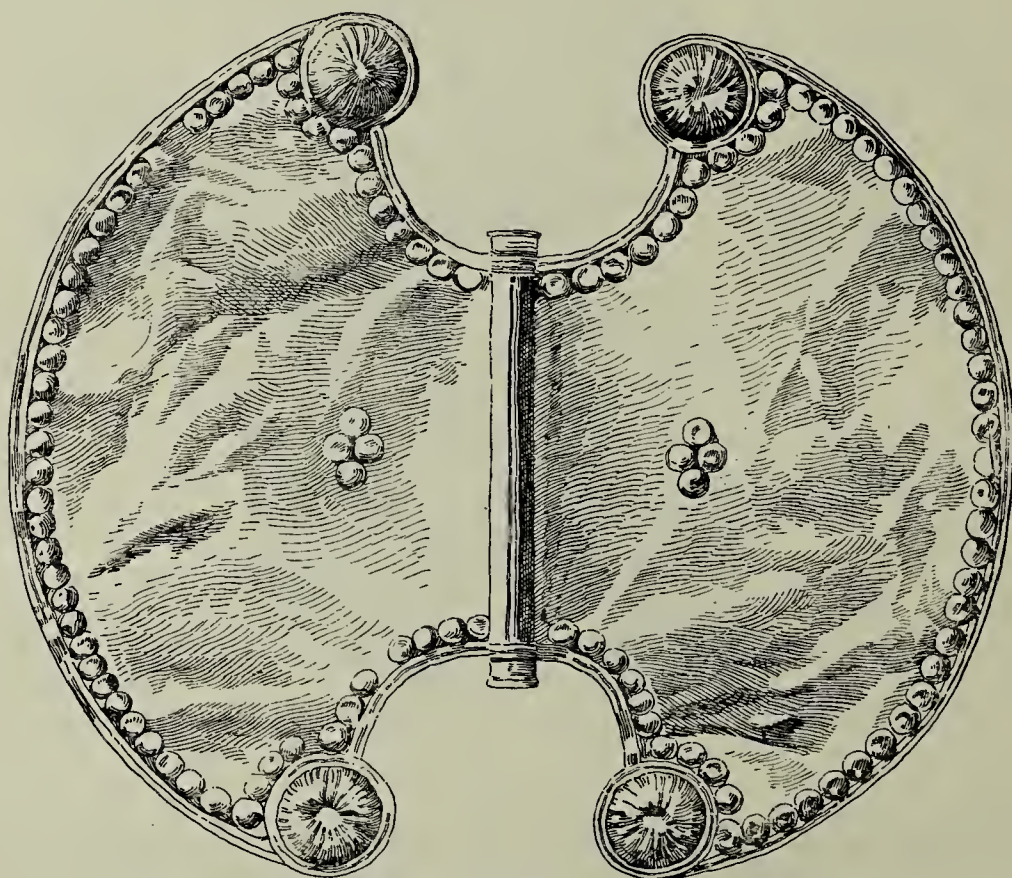

FIG. 206.—Lydian trinket. Height, 99 c.; length, 89 c. Louvre. Drawn by St. Elme Gautier.

by a tube, adorned by three sets of rings and a granulated edge (Fig. 207). They are followed by two more discs of exactly the same type, but without tube, and sixteen ornaments semi-cylin-

dricul in shape, or annulated, with staples at the back for attachment (Fig. 208). The last object is a simple twist of gold thread of considerable size, with an oblong hole at one end. The twenty-five pieces which made up the treasure, have all the appearance of having come out of one workshop, and of being the work of one hand. We have here the remains of one or two sets of ornaments. Thanks to the tube on which the gold plaques are mounted, the perforations that appear on them, and the hooks at the back, they could be easily secured to the dress; here and there, too, are very tiny holes for the passage of thread. The mingling of two processes, which, as a rule, exclude each other, will be observed. The artificer who wrought these ornaments knew how to solder gold; for in this way were fixed every one of the minute granules that form an ornament of astonishing fineness; at the same time, when he wished to insert and secure the heads of the animals in the field of his principal plaque, he went to work as one ignorant of the first principles of his craft, and found no better contrivance than letting down the end piece at the back, rivet-wise (Fig. 204).

That these jewels are the outcome of an advanced art is proved, both by the plaques of metal beaten out into great thinness with the mallet, and the *repoussé* work done with the graver; it testifies to an art that makes light of difficulties, and knows how to turn out forms and ornament pleasing to an educated eye. If these trinkets are from the hand of a Lydian, they must have been wrought in the time of Gyges or one of his successors. The heads of the animals adorning them recall those on Lydian coins of the same period, characterized by firm vigorous make. On the other hand, if we find here elements borrowed from Egypt, their presence is to be accounted for in the relations entered into between the Lydian empire and Egypt from the advent of the Mermnadæ, the latter furnishing Egypt with those Carian mercenaries, whose profession took them backwards and forwards

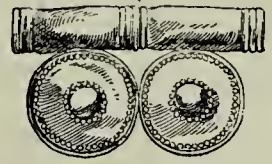

FIG. 207. — Lydian trinket. Height, 16 c.; length, 26 c. Louvre. Drawn by St. Elme Gautier.

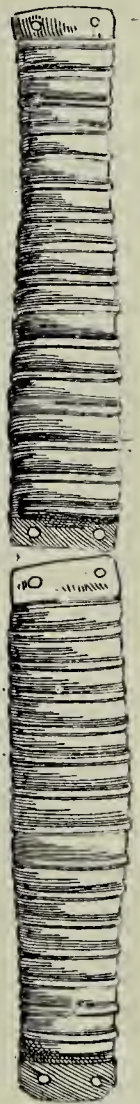

FIG. 208. — Lydian trinket. Length of either cylinder, 48 c. Louvre. Drawn by St. Elme Gautier.

between the two countries. In the preceding period, Lydia had been unacquainted with the Delta, and her art had no other repertory to draw from than that of Syro-Cappadocia. Another hypothesis which has nothing improbable about it may still be adduced; namely, that the jewellery we are considering might, after all, be of Punic fabrication. The points of resemblance it presents with those admirable pieces that came out of a tomb at Camiros are both striking and numerous.¹ There is the same mingling of human and animal forms, of heads wreathed in the *klaft*; whilst the situation given to the female image on one of the pieces from Camiros and another from Aidin, is precisely similar to that of our goddess, save that there it is full face, quite nude, and half dressed here. The image is supposed to be the Asiatic goddess Qadesh, who appears on Egyptian monuments with so peculiar a physiognomy.²

Whether these ornaments were fashioned in the kingdom of Cræsus, or brought by an adventurer from Syria or Egypt, matters little, and does not preclude the fact that their exquisitely fine workmanship could not but render them objects as rare as they were costly. Long before Lydian craftsmen were capable of executing pieces as complicated as these, jewellery whose chief value resided in the material of which it was made, must have been turned out by much simpler and more expeditious methods. By means of a mould of some hard stone, personal ornaments, pieces to be sewn on to garments, small figures or amulets, could be cast in vast numbers. The mould of serpentine figured on next page was used for making pieces of this kind (Fig. 209). It was found a few years ago near Thyatira, and placed in the Louvre collection.³

That the slab, 15 centimetres thick, is a jeweller's mould, is proved from the fact of the gutters that appear upon it, and which can only have been used to receive or drain the liquid metal. Similar moulds have been found in Assyria; but the interest that attaches to this particular one is the size and character of the

¹ The gold objects in question are due to the excavations of M. Salzmänn. They form part of the Louvre collection, and an account of them will be found in *Revue arché.*, 2^e Série, tom. viii. pp. 1-6, Plate X.

² PIERRET, *Le Panthéon égyptien*, p. 46.

³ A circumstantial account of the mould in question, discovered by M. S. Reinach, may be read in his paper, "Deux moules asiatiques en serpentine" (*Revue arché.*, 3^e Série, 1885, tom. v. pp. 54-61). The memoir has been republished in a separate volume, under the title *Esquisses archéologiques* (8vo, Leroux, 1888), pp. 44-51.

figures that make up the pattern. One is a nude woman; the hands point to her breast, and the abdomen and the pelvis are rendered with gross realism. Examples of this clumsy insistence have already been figured in this history, in reference to the terra-cottas of Susiana and the ivories of Assyria.¹ Left of this personage is another somewhat smaller, robed in the long tunic of a Chaldæan priest, with six flounces of crimped work. The



FIG. 209.—Mould of serpentine. Actual size. Louvre. Drawn by Wallet.

characteristic gesture of the female figure, the absence of any drapery, proclaim the goddess-mother, Istar or Anahith, of the religions of Anterior Asia.² From the fact that the dressed personage has no special attribute, we find greater difficulty in giving him a name; one is tempted to recognize in him a god rather than a priest, since the images produced by the mould would be meaningless, unless they were portable puppet-gods or Lares.

The other subjects incised on the slab of serpentine are less

¹ *Hist. of Art*, tom. ii. Figs. 16, 231, 232.

² *Ibid.*, pp. 82, 505, 507, 606; tom. iii. pp. 419, 450, 455, 610, 783; tom. iv. pp. 532, 808.

important. The lion on the right, with a ring on his back, recalls those that were discovered at Nineveh,¹ and which served as weights. We may take it as a sure sign that the pattern was most in favour and widely diffused. The singular part about it is the stick he holds between his paws. Next to Anahith, on the left, appears an altar, or four-storied tabernacle; the two uprights at the sides spread palm-wise into six points or fingers, whilst between them protrudes a semi-circular form. Very similar tabernacles are depicted on a certain class of Mesopotamian monuments.² The globular shape brings to mind the round stela which crowns the stone-cut sanctuaries in Midas city (Figs. 103, 104, 106). As to the diminutive circular shield and the rectangle that take up the rest of the field, all that can be made of them is that they are large-headed buttons, whose function was to put the finishing touch to dress or furniture. The left disc, in the lower corner, looks like a six-rayed star.³

The divine types and subsidiary devices which accompany them so closely resemble those of Chaldæan tradition, as to challenge the query whether the mould may not, after all, have been brought from Mesopotamia to Asia Minor, by one of those strolling jewellers one often meets in the East in the present day, at long distances from their native place.⁴ On the other hand, the work is so exceedingly coarse and rude, the design hard and conventional, that it would reflect the greatest discredit on the technique of Chaldæan artists to father it upon them. On the contrary, if we suppose a people inferior to the Chaldæans from a cultured standpoint, whose mediocre engravers copied mechanically foreign models, coarse, heavy manipulation will no longer surprise us, but will appear quite natural. No matter what the rights of the case may be, it is none the less hard to believe that uncouth works such as these were fabricated in the age of the Mermnadæ, under whose rule Lydia was in direct relationship with Egypt and Assyria on the one side, whilst on the other she was beginning to feel the influence of Ionian art, which at that time was fast progressing towards perfection. As far as workmanship will enable us to judge, the slab would seem to be many

¹ *Hist. of Art*, tom. ii. Plate XI.

² *Ibid.*, Figs. 68, 79, 233, 301.

³ Compare the sidereal shapes figured on Chaldæan stelae, *Ibid.*, Fig. 10.

⁴ *Ibid.*, tom. iii. p. 448.

centuries older, perhaps, than the reign of Gyges; and would, therefore, lead back to the period when the only intercourse Lydia had with the great civilized nations of Anterior Asia was through the intermediary of the Syro-Cappadocians, when Greece was not. What the images engraved upon it specially recall are the most barbarous works of what we have called Hittite art; for example, the bas-reliefs of the Eyuk palace.¹

The cabinet of antiquities of the Bibliothèque Nationale has another mould of serpentine, the origin of which is unknown (Fig. 210). It represents a man and a woman standing side by side.

His dress is a short tunic falling short much above the knee, and a mantle thrown over one shoulder, leaving apparently the other arm and the legs exposed. He wears a long thick beard, and his head is covered with a kind of pointed helmet. The arms are bent and rest upon the chest, a movement repeated by his companion, whose fingers point to, but do not close upon her breasts. Her arms and bust are frankly nude, but the skirt, her only item of dress, reaches to her ankles. Upon her crescent-shaped head-dress are traced geometric characters. Her luxuriant hair falls in thick ringlets on either side of her face. The two bars rising obliquely on each side of her, may perhaps be explained as remains of the apparatus required for casting the figure.

When the mould under notice was discovered some twenty years ago, and attention drawn to it, it was attributed to the twelfth century A.D. and described as an image of *Baphomet*, to which the Templars, said their enemies, were wont to offer idolatrous homage.² At that time, however, the ancient art of Asia was so imperfectly known as to render the mistake excusable. Our better informed judgment cannot hesitate to recognize in it a monument precisely



FIG. 210.—Mould of serpentine. Actual size. Cabinet des Antiques.

¹ *Hist. of Art*, tom. iv. Figs. 328–338.

² CHARBOUILLET, *Catalogue général et raisonné des camées et pierres gravées de la Bibliothèque impériale*, 8vo, 1858, No. 2255.

similar to those that have been collected in Assyria and Asia Minor. It is made of the same material as these, and certain details are amazingly alike. If the execution betrays a lighter hand than appears in the Louvre specimen, there is no doubt as to the treatment of the dress having been copied on the same models, instanced in the horizontal bands which make up the flounced skirt, and the markings of the same in imitation of crimped work. Broadly speaking, the details that distinguish the female figure under consideration from that of the Lydian mould are but trifling; if she is partly dressed, if her gesture is somewhat modified, the divine type and characteristic attitude are exactly alike. As to the male figure, his head-covering is the pointed cap so often seen on the rock-cut bas-reliefs of Asia Minor, and the seals of her primitive inhabitants.¹ The two horn-like appendages flanking the helmet resemble the uræus-shaped ornament about the cap of the chief personage in the bas-relief at Ghiaour-Kalessi.² Finally, at the sides, on a line with the brow, there seems to be a holed (two?) salience, akin to that which appears in the same situation about a bronze figurine from Central Anatolia.³

The instances that have been adduced render it highly probable that both the smaller and the larger slab are from Asia Minor. In the former exemplar, the figures are less removed from reality; there is more precision and sureness of hand than can be claimed for the Louvre mould, but it exhibits a certain degree of dryness, which, it has been justly observed, seems to indicate that its fabricator was accustomed to metal engraving. Taken altogether, it looks less ancient than the Thyatira intaglio, but this notable difference may be due to another cause; it is just possible that the monument originated from a more important centre, whose craftsmen had better patterns to work from and better training.

If there are reasonable grounds for believing that the use of high-class jewellery was in great favour in that Lydia so rich in precious metals, it is likely that the demand for luxurious art furniture and fine apparel, soft tissues for furnishing the palaces of princes and the houses of people of distinction, was fully as great. Thus the stone-beds of the Lydian tombs are more ornate than those of the Phrygian necropoles. Observe how much simpler in composition is the specimen we described in one of the vaults at

¹ *Hist. of Art*, tom. iv. pp. 546, 562, 692, 722, 744, 760.

² *Ibid.*, Fig. 352.

³ *Ibid.*, Fig. 367.

Doghanlou Deresi (Fig. 211),¹ as compared with the fragments that came out of the tumuli at Bin Tepe (Figs. 178, 179). Fine clothes were part of the "soft vanities" which the wise Greek philosopher, Xenophanes of Colophon, rebuked his countrymen as having learnt of the Lydians.² From their neighbours of Sardes, says the poet, "the Ionians had borrowed those robes of purple in which they were wont to appear in the agora, those gold ornaments that glittered in their profusely scented hair."³ Data such as these suggest the idea of an existence at once luxurious and brilliant, well calculated to dazzle and charm the Greeks of the coast. It was at Sardes more particularly that they beheld and admired those many-coloured robes, whose elegant and varied designs the

vase-painters of a later period were to introduce in their pictures of Oriental and mythical personages, Priam and Paris, Atys and Midas, the Amazons and Omphales. Textiles were among the early industrial

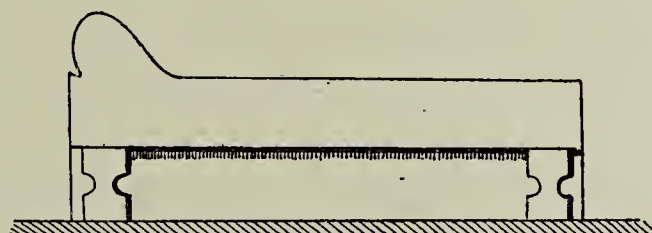

FIG. 211.—Funereal Phrygian couch. Drawn by G. Guillaume.

products that found favour and flourished in Lydia, and, despite the many vicissitudes and political changes that have swept over the country, they have ever continued to be made with taste and success. Sardes was justly proud of her short-nap carpets, for which high prices were paid.⁴ At the present day the so-called Smyrna carpets are manufactured at Gherdiz (ancient Gordis) and Ushak, on the Upper Hermus; that is to say, within the limits of ancient Lydia.

Fine beautiful work done by Lydian women was not confined to weaving and embroidery. There were other handicrafts they carried on with equal skill and patient labour. Of these one is incidentally mentioned in the *Iliad*, where Homer sees the white skin of one of his heroes suddenly stained with blood, and turning

¹ The bed in question is found in the tomb described, pp. 121, 122, Figs. 72-74. See Heuzey.

² Xenophanes, Fr. 3: 'Αδροσύνας δὲ μαθόντες ἀνωφελέας παρὰ Λυδῶν (BERGK, *Fragm. Lyr. Græc.*, tom. ii.).

³ Προήεσαν διησκημένοι τὰς κόμας χρυσῷ κόσμῳ, says Athenæus (xii. p. 526, A). His reading (doubtless after Phylarchus, whose witness he invokes) of Xenophanes's line is thus rendered in our text: ἀρχαλέοι χαίτησιν ἀγαλλόμενοι εὐπρεπέεσσιν.

⁴ They were designated as ψιλόταπις or ψιλόδαπις (Athenæus, vi. p. 255, E).

red around the wound inflicted by the sword. He compares it with ivory dyed with purple by the hand of a Lydian or Carian woman, as she sits at her work and decorates the bridle destined for the war-horse of the king, a bridle that all the other warriors will covet.¹ The harness of the famous Lydian cavalry was doubtless ornamented with inlay, a mode of enrichment that has never been out of fashion in the East, abundantly proved by the specimens exposed for sale in the bazaars of Bagdad and Cairo.

GENERAL CHARACTERISTICS OF LYDIAN CIVILIZATION.

The task we have taken upon ourselves involves the collecting of the minutest remains in which the hand of the Lydians may be traced, together with the most casual literary mention having reference to their art and industry. Nevertheless, if our attention had no other criterion outside the monuments that exist above ground to guide it, there is no doubt but that Phrygia would appear worthy of a larger place than Lydia in this history of civilization. But, though specious, the conclusion would be unsound, and in danger of being upset in favour of the Lydians, whenever explorations among the ruins of Sardes—which cannot be long delayed—shall furnish proofs of the constructive and industrial superiority of Lydian craftsmen. Besides, even now, before the discoveries are made, traditions that have come down to us testify to a country whose political and international action was far in advance of anything Phrygia can show. The Phrygians were above all tillers of the ground; they raised cereals, reared cattle and sheep. Agriculture was equally in favour with the Lydians; their meadow land nourished kine as numerous, and a breed of horses which for the space of a hundred years and more made their cavalry the best in the Oriental world. Their practical turn of mind and trading propensities, however, found uses for their horses other than those of war. Long processions were to be seen slowly trending their way along the paths that follow the course of the Hermus, the Caÿster, and the Mæander, laden with fruit from field and orchard; merchandise obtained from their Asiatic or Greek neighbours, as well as the manifold productions of their workshops; woven fabrics and carpets, tiles and vases of home manufacture; gold won from the depths of Tmolus, which the

¹ HOMER, *Iliad*, iv. 141-145.

crucible had converted into portable bars. The productive activity of the colonist, the artisan, and merchant had more to do with creating the wealth of Lydia, than all the washings of her auriferous sands, the contemplation of which gave the Greeks their first insight into the power of capital.

In a restricted sense, a phenomenon of a similar nature had already taken place in Phrygia. The Greeks nowhere extracted the noble metals from their soil; they only obtained them by way of exchange. This it was which caused their lively imagination to exaggerate the importance of the gold fields the Phrygians were supposed to possess in the flanks of their mountains, and the beds of their torrents; they invented tales which, sprung from childish credulity and wonderment, a later age endowed with moral and philosophical import. The untold wealth of Midas had been no good to him; it disappeared along with that of the country, both during the Cimmerian invasion and the wars that had to be carried on against the Medes and the Lydians. The affairs of Lydia took a different turn, and she retained her autonomy for another hundred years. In the meanwhile, her military preponderance caused a large proportion of the capital, that had accumulated for centuries in the most thriving parts of the peninsula, to flow in the royal treasury. Thanks to her commerce and industry, the difference of exchange was always to her benefit, so that whatever gold came out of the soil circulated within the territory, either for the use of her princes and merchants or that of the country generally. The superabundance and plethora of the noble metal suggested the first idea of an invention which will ever shed lustre on the Lydian name.

The glory of Phœnicia is to have made the civilized world richer with an alphabetical writing; that of Lydia to have given it a monetary system. This she did when she put a stamp upon her ingots, thereby endowing them with a fixed official value, that made them acceptable and things to be desired throughout the vast empire, which had Sardes for its capital.

In the sequel of this history, we shall show what splendid use the art of Greece and Rome made of the double field yielded by the two faces of the coin, and how medal-engraving became one of the most flourishing branches of sculpture, one that was productive of the richest and most exquisite harvest. No effort of plastic genius conveys, in the same degree, the impression of

stupendous difficulties overcome, as a certain class of pieces that wring our admiration at the way the engraver managed to introduce in so limited a space an image which, however reduced, is endowed with a breadth only to be found in the noblest statue. We marvel how, with so feeble a relief, he was able to put every feature in its plan, and faithfully render the modelling of the face, the roundness of the living form. If of a truth we are right—and we think we are—in believing that to the practical and ingenious mind of the Lydians we are indebted for an invention that was forthwith taken up by the Greeks, in whose hands types created by statuary were multiplied and sown broadcast, this is sufficient reason why history should be interested in the Lydian people, and should feel in duty bound carefully to seek and describe the scanty remains of their civilization.

Nor is this the only thing which entitles Lydia to be considered as worthy of solicitous regard. The phenomena we have observed in Phrygia are likewise manifested here, but with much greater intensity. We allude to the ascendancy which, towards the end of the seventh century B.C., the genius of Hellas began to exercise over that Asia of which she had at first and for centuries been the client and disciple, when, with a sudden reversing of the parts, she not only carried her interference on the eastern coasts of the Mediterranean, but some way inland as well, and penetrated with each succeeding age further into the interior of a continent her hosts were to conquer under the leadership of Alexander.

If the action of Hellenic civilization was felt with even greater energy within the boundaries of Lydia than in those of Phrygia, it was because Sardes is closer to the sea than Pessinus and Ancyra, because contact between Lydians and Ionians was direct and uninterrupted, and mutual intercourse more rapid and intimate. Whilst monarchical Lydia, by sheer superiority of arms, reduced the Ionians to a state of vassalage, these turned the tables upon their masters and morally subdued the kingdom. When Cræsus fell, he was on the point of declaring himself a Greek prince; he was already in the enjoyment of the rights belonging to a Delphian citizen,¹ and had he lived, he would, doubtless, have obtained the privilege of sending his horses to run the races at the great public games of Greece, and Pindar would have celebrated the victories of one of his successors, as he did those of Gelon, Hiero, and

¹ Herodotus, i. 54.

Arcesilas. In time the Mermnadæ would have acquired on the east of the Ægean Sea a situation analogous to that which the Philips and the Alexanders won for themselves on the north of this same sea. All that would have been required of a Mermnad prince, to be accepted on equal terms into the body of the Hellenic nation, would have been to trump up a pedigree connecting him with the mythic lover of Omphales, or some equally famous hero. Had history taken that turn, the world would have been given the spectacle of an Asiatic Macedon, in which the great natural gifts of the Hellenic race, her energy and intelligence, her love of liberty, which had been fostered by municipal franchise of long standing, all would have been placed at the service of a great military power. Greek culture would have spread to the Halys, and perhaps beyond the Taurus range, two hundred years earlier than it actually did.

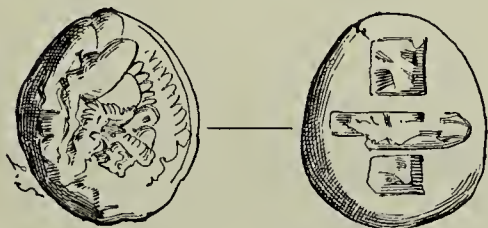

CHAPTER III.

CARIA.

HISTORY OF THE CARIANS.

THE name of Caria was applied in antiquity to a hilly district, southward of Asia Minor, which stretches between the mouth of the Mæander and the impetuous stream called the Indos (Doloman Tshai). The latter descends from Cibyratides and falls into the sea opposite Rhodes. It is a country bounded by the mountain chains of the Messogis, the Cadmos, and the Salbacos, which serve to separate it from Lydia on the north, and Southern Phrygia on the east; whilst the lofty mountains of Lycia oppose a formidable barrier on the south-east.¹ Caria belongs almost entirely to the Mæander basin; its shores are broken up throughout into very salient peninsulas and deep gulfs; but whilst the maritime frontage of Lydia and Mysia fell into the hands of the Ionian and Mysian Greeks, the Carian population managed to retain most of their coast line. The province counted little more than three important Greek centres, of which two rose at the extremity of long promontories in touch with the continent by a narrow tongue. These, to take them in their order from north to south, were potent Miletus, the acknowledged queen of Ionia until the day when her well-sheltered roadstead, which served her as harbour, was silted up by the deposits of the Mæander; next came Halicarnassus and Dorian Cnidus. Veritable ships riding at anchor, these cities derived their main resources from maritime enterprise; hence they were content with suburbs of no great extent, and, except in their immediate neighbourhood, all the rest, dominated by the crested heights of Latmos, was occupied as of

¹ Strabo, XIV. ii. 1.

yore by the Carians. It was a coast whose every winding formed a safe anchorage, whilst behind each jutting cape or slit in the mountain, were narrow creeks in which the mariner could find shelter, and when all was snug the crew could drop on the fine sanded beach.

Caria was conquered by the Mermnadæ, and became a mere dependency of Lydia; before the fortune of war, however, had brought about the reunion of the twin nations, the kinship existing between them had been fully recognized. Thus, when the Carians were asked as to their origin, they told Herodotus that their ancestors, as those of the Lydians and Mysians, were brothers of the respective names of Car, Lydos, and Mysos. It was owing to this primitive affinity, they said, that the Lydians were permitted to pay homage to their national deity on the same footing as themselves.¹ The god in question, whom the Greeks identified with Zeus, was worshipped under the name of Labrayndos, Labraundeus, Labradenos, near Mylasa, where he had a temple. The qualificative was not a local proper name, but derived from *λάβρις*, the Lydian word for "axe," which he carried in his hand (see tail-piece, end of chapter).²

Proper Carian appellatives, whether of individuals or places, have naught that is Semitic about them; ³ nor are the few common nouns preserved in the glossaries of lexicographers to be explained

¹ Herodotus, i. 171; Strabo, XIV. ii. 23.

² *Λυδοὶ λάβρυν τὸν πέλεκυν ὀνομάζουσι* (PLUTARCH, *Gr. Questions*, 45). Many other words are put forward as common to Lydian and Carian, or at least sufficiently near one to another as to yield, when submitted to analysis, identical roots (see glosses bearing upon *γλοῦς*, thief; *Μάσαρις*, or *Μάρσαρις*, a surname of Dionysios among the Carians, which appears to be a dialectical variant of the Lydian *Βασσαρεύς*; *Κανήβιον*, "dog-city," a Carian centre, with the initial *καν* is likewise found with the same signification, in the Lydian name *Κανδαύλης*. The double-edged axe often appears engraved, as a kind of coat of arms, above the Greek inscription of Caria (*Bull. de corr. hell.*, xi. p. 310).

³ See the list drawn up by Haussullier (*Bull. de corr. hell.*, 1880, iv. pp. 315-320) and Sayce ("The Karian Language and Inscriptions," *Trans. Bibl. and Archæ. Soc.*, vol. ix. part i., 1887). The only local Carian name that looks Semitic is that applied to Mount Cadmos, rising to the eastward of the Mæander valley. In the first syllable may be easily recognized *kadem*, east. We can well understand how the Phœnicians, as they ran along the coast of the Ægean, on the tract of their counting-houses and mines, should so have designated a conspicuous landmark bounding their horizon in the east. The fact that the appellation has survived them may have been due to the natives having caught it up of the Phœnicians, with whom they were in perpetual intercourse.

by Semitic methods, whilst a certain proportion are easily traceable to Aryan roots.¹ In the seventh century B.C. the Lydian language was written with an alphabet of from thirty-three to thirty-five letters.² Of these the vast majority was derived, through the intermediary of the Doric syllabary, from Phœnician characters, whilst the remaining signs had their origin in one or other of those older systems we have called Asianic alphabets, and which, by way of reduction and abbreviation, came out of Hittite hieroglyphs, so as to express sounds proper to Carian.³ Caria, up to the present hour, has yielded but one inscription written with the syllabary under notice, so that our knowledge of it is chiefly derived from

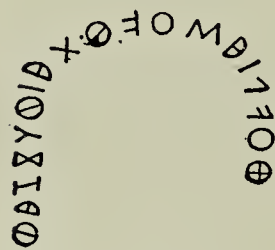

FIG. 212.—Carian inscription. Zagazig, Egypt. Sayce, Plate I., No. III.

Egyptian *graffiti* (Fig. 212).⁴ The texts are all very short, and, as a rule, consist almost entirely of proper names; nevertheless there are a few nominal and verbal forms which seem susceptible of being inflected and conjugated as the nouns and verbs of the Indo-Germanic languages.

We know next to nothing of the religion of the Carians; at least, what we know is taken from documents relating to an age when the Carians used Greek as their speaking language. It is generally acknowledged that the Carian religion admitted of orgiastic and bloody rites, of the nature of those enacted in honour of Cybele and Atys;⁵ that, as in Lydia and Phrygia, the plaintive, soul-moving melodies of the flute likewise obtained here.⁶ From such indications as these we surmise a people addicted to the worship of the great goddess of nature, whom the Greeks of Asia Minor designated in places as Cybele, whilst elsewhere they confounded her with Artemis;⁷ but the cult which more than any other left traces

¹ DE LAGARDE, *Gesammelte Abhandlungen*, pp. 267–270; SAYCE, *The Carian Language*, pp. 5–9.

² See Plate I. Sayce's memoir, in which all the characters, with their certain or probable values, are duly set forth.

³ *Hist. of Art*, tom. iv. p. 95; tom. v. p. 218.

⁴ Professor Sayce's memoir, dated 1887, has a complete collection of all the inscriptions which may reasonably be regarded as Carian, and three plates containing fac-simile reproductions and transcriptions, including explanatory notes of the texts.

⁵ Herodotus, ii. 61.

⁶ Eustathius, commentary to verse 791 of Denys Periegetes.

⁷ The Hecates of Lagina, near Stratonice, where she had a temple, was perhaps no more than a Greek form of the Asiatic deity (TACITUS, *Annals*, iii. 62). In regard to the public rites of which she was the object, consult the inscriptions

and authentic monuments of its existence is that of the supreme god, honoured not only within the territory of Mylasa, but on many a point of Caria, where sanctuaries, each the centre of a local confederation, were in high repute as late as Roman times.¹ Of the different names used by epigraphic texts to designate this deity, who seems to have been endowed everywhere with pretty much the same character, two are specially deserving our attention, namely, Ὀσογῶς, an epithet applied to the Carian Zeus, and which certainly covers a word of the ancient native idiom ;² and the title of Ζηνοποσειδών, which again and again occurs in the inscriptions of Mylasa.³ The term seems to indicate that the great deity of the Carians was both god of heaven and of the sea. Thus, at certain seasons, the paving-stones of the temple at Mylasa were supposed to be washed by sea waves, although a distance of eighty stadia (twelve kilometres) separated it from its seaport.⁴ Nothing of the kind has been discovered in Lydia ; nevertheless, in the time of the Mermnadæ, she had annexed to her dominions the whole of the western coast. These conquests, however, had come too late to effect any permanent influence on her religious and social condition. Her gods, as those of Phrygia, dwelt on lofty summits and in gloomy forests ; they were indifferent to storms, which they did nothing to raise or quell, and the worshippers that frequented their shrines were ploughmen, horsemen, artisans, and caravan-traders.

collected by Sir C. Newton (*A History of Discoveries at Cnidus, Halicarnassus, and Branchidæ*, ch. 24, and Appendix, tom. ii. pp. 780-803), as also those published by the syndicate of the French School at Athens, brought back from a recent visit to Caria (*Bull. de corr. hell.*, tom. v. pp. 185-191 ; tom. xi. pp. 3-30, 145-162). The Hecates under notice had her "mysteries," a fact which suggests ceremonies akin to those that distinguished the Phrygian cult. We should like to hear something more about the "key pageant" (κλειδὸς πομπή, or ἀγωγή), which, from the sacred precincts, repaired to the neighbouring town of Idrias, subsequently called Stratonice, amidst an immense concourse of people (*Bull.*, xi. p. 47).

¹ Within the territory of Mylasa alone were three temples in honour of Zeus, *i.e.* one to Zeus Carios, common to Carians, Lydians, and Mysians ; another to Zeus Osogos, and the third to Zeus Stratios, also called Labrandeus, from the name of the mountain crest, where it rose about midway between Mylasa and Alabanda (Strabo, XIV. ii. 23). With regard to Zeus Panamaros, the tutelar deity of Idrias, see Deschamps and Cousin, *Bulletin*, xi. pp. 373-391 ; xii. pp. 82-104.

² Osogos is sometimes met with in an undeclined form, as ὄσογῶα, and at other times we find it inflected. Consult Waddington's Commentary, No. 361, Part v. ; *Voy. Arché.* of Le Bas ; and *Bulletin*, xii. pp. 13-14.

³ Bœckh, *C. i. gr.*, No. 2700 ; Le Bas, *Voy. Arché.*, Part i. No. 361.

⁴ Pausanias, VIII. x. 4.

Wholly different was the temper of the Carians; when they appear on the historical scene, set up by Greek genius, they could already boast a long past spent in maritime adventure; and though details escape us, reminiscences of their former deeds lingered for centuries in the eastern basin of the Mediterranean. They themselves preserved the traditions of a time when they had overrun the Ægean as their special property on their voyages round their settlements, in and out of the isles speckling her vast bosom, as well as certain points of the Greek mainland, where they founded Hermione, Epidaurus, and others of minor fame.¹ In that remote period they had been accompanied in their daring enterprises by the mysterious Leleges, whose love of adventure or booty was in unison with theirs. It would appear that whilst the Leleges established themselves in Laconia, Bœotia, and Megarides, the Carians, true to their maritime instincts, occupied Argolid,² and spread along the coast line which later was called Ionia and Æolia, where they selected the sites and built the first dwellings of those cities which, under the name of Ephesus and Miletus, were to attain so brilliant a destiny.³ To what stock belonged the Leleges, and what language did they speak, are questions it is impossible to answer; since when Greek historians first began to write, they were already forgotten, and had disappeared without leaving a trace. Nevertheless, popular tradition persistently allied their name with the antique tombs and fortresses with which Caria was interspersed;⁴ it further stated that in order to people his newly built capital, Mausolus, the famous Carian dynast, had forcibly carried off the inhabitants of six villages of the Halicarnassian peninsula.⁵ If the ancients were unable to solve the problem as to the nature of the link which had formerly bound Carian and Lelege, it is not likely to be settled by modern research. The view of Herodotus, or rather Pherecydes, and many other writers, to the effect that the name of Leleges was one of the many designations by which the Carians were known,

¹ Herodotus, i. 171; Thucydides, i. 8; Aristotle, cited by Strabo, VIII. vi. 15; Strabo, XIV. ii. 2.

² Aristotle, cited by Strabo, VII. vii. 2; Pausanias, III. i. 1; IV. i. 2.

³ Strabo, VII. vii. 2; XIII. i. 59; XIV. i. 21.

⁴ *Ibid.*, VII. vii. 2; XIII. i. 29.

⁵ *Ibid.*, XIII. i. 59. PLINY (*Hist. Nat.*, v. 29) ascribes, doubtless from lack of memory, this same measure to Alexander the Great.

the distinctive of a tribe belonging to the Carian group, is, on the whole, that which seems most probable.¹

Be that as it may, under one name or another, the Leleges certainly played an important part in those far-off days, which merge and disappear in the cloudland preceding the Homeric horizon. Along with the Carians, they would seem to have been the first who boldly turned their light skiffs towards the Sporades and the Cyclades, over the space stretching from Asia Minor to Crete and the more distant coast of the Hellenic peninsula;² the first, in fact, who opened up relations between these many lands, which once set on foot were to go on to the end of time. Traders and pirates as occasion served, they sailed, as the Phœnicians had done before them, from Asia to Europe, and from Europe to Asia. Their cargoes consisted of the products of the soil, of fabricated goods, and slaves; women they had surprised at the public fountain, labourers snatched from their field occupations. The bands would land at night, conceal themselves in the neighbouring thicket or a rocky cave, and emerge from their ambush with the first morning light, when, falling upon whatever they found within reach, they carried all on board ere time was given for sounding the alarm. It was a violent procedure, yet, strange as it may seem, productive of the happiest results, in that it brought together people who, but for these compulsive displacements, would ever have remained estranged one from another. Interchange, whether of ideas or beliefs, or of outward symbols consequent on the latter, would have been impossible; nor would instruction of a more practical nature, crafts, and industrial secrets peculiar to each have been learnt.

The date when the Carians first began to lose ground may be put at the first appearance of the Punic galleys in the Ægean; for, as pupils of Egypt and Chaldæa, and intermediaries between these and the countries bordering on the Mediterranean, the

¹ Herodotus, i. 171.

² Strabo, XII. i. 59; XIV. i. 3; Pausanias, VII. ii. 8. Homer (*Iliad*, x. 428), in his enumeration of the Trojan allies, distinguishes Carians from Lelegians, the fact in itself does not in any way invalidate the conclusion that the twin groups had originally sprung from the same family. A native historian of Caria, Phillippos of Syangela, states that the Leleges occupied towards the Carians a position akin to that of the Helots towards the Lacedæmonians, and the Penestes to the Thessalians (*Athenæus*, vi. 271, B.). A passage in Plutarch (*Quæst. Græc.*, 46) would seem to bear out the assertion.

Phœnicians represented a culture superior to that of Caria. Then came by turn Greeks, Ionians, and Dorians, who in their progressive stages gradually drove the Carians out of the island, or became fused with such of them as had not been expelled or annihilated. Hence it came to pass that in or about the eighth century B.C. the Carians ceased to exist as a compact and distinct group, save in that province of Asia Minor which has preserved their name. But although they had long been playing a losing game, and had been obliged to withdraw more and more before the invader, they had lost none of their roving proclivities, and their name as soldiers stood as high as ever. Herodotus credits the Carians with three inventions that were afterwards adopted by the Greeks;¹ namely, the fashion of putting plumes about their helmets, and ornamental figures on their shields, which they shifted and kept in place by means of a leather strap slung over the neck and left shoulder, and also fitted with a handle; for until then, every one who made use of a shield carried it without a handle.”²

We must turn to Caria, therefore, for the prototype of the Greek hoplite; as also for the example she gave to the sons of Hellas, of selling their services to Asiatic and Egyptian monarchs.³ Both Carians and Ionians penetrated into Egypt as early as the reign of Psammeticus I., and henceforward the flow never ceased.⁴ Better armed and of a more bellicose disposition than the natives of the Delta, thoroughly versed, too, in their profession, they formed, under commanders selected from their own ranks, the main force of the armies the Saït Pharaohs moved in the field. These had established them in what were called “The Camps,” on the Pelusiatic branch of the Nile; whilst the Ionians occupied the other side of the river. Somewhat later, in the reign of Amasis, quarters were also given them at Memphis.⁵ Of these mercenaries, whom age or wounds had unfitted for active service,

¹ Critias, a poet of the fifth century B.C., referring to the inventions due to different nations and different cities, expresses himself as follows:—

Θήβη δ' ἄρματόεντα δίφρον συνεπήξατο πρώτη,
φορηγούς δ' ἀκάτους Κᾶρες ἀλὸς ταμιαί.

² Herodotus, i. 171.

³ To talk of a Carian, in the seventh century B.C., was synonymous with soldier of fortune. Thus Archilochus (BERGK, *Poetæ lyrici græci*, Frag. 24): Καὶ δὴ 'πίκουρος ὥστε Κάρ κεκλήσομαι.

⁴ Herodotus, ii. 152.

⁵ *Ibid.*, 154.

all did not return home; many found it so snug that they permanently settled in Egypt, where they became dragomans, like the Greeks and Maltese at the present day.¹ The bronze statuette of Apis, in the Boulak Museum,² with a bilingual inscription on its base (in Egyptian hieroglyphs and Carian letters), is not the only instance which testifies to the part the Carians played in Egypt; even without the great authority of Herodotus, the notes they have left behind them would have led us to guess as much. Thus, from Ipsamboul to Memphis, their names are incised on the rocks of the Nile valley and the walls of temples, side by side with those of Greek or Syrian adventurers and Punic traders. Professor Sayce has collected and transcribed fifty Carian *graffiti*, and fresh researches cannot but add to the number. Of these, forty or thereabouts were discovered at Abydos.

If the language and writing of the Carians have left most traces in the Nile valley, monuments, architectural and artistic, which may be ascribed to this people, have not been found outside Caria. Do all such monuments lead back to the period of the independence of Caria? Did they witness the rise and fall of the Mermnadæ, the conquest of the Persians? We do not care to commit ourselves to a decided opinion; besides, it matters little. The inscriptions seen about the principal sanctuaries tell us plainly how faithful were the Carians to their gods and local cults, even in the full swing of Roman dominion; hence we cannot admit that change of masters induced them easily to change their methods, whether in their constructions, mode of burial, vase types, jewellery, and so forth, with which they had long been familiar. All the monuments, therefore, encountered on native soil, wherein Grecian style and Grecian taste are non-apparent, may be considered as Carian.

FUNERAL ARCHITECTURE.

Those tombs which in the time of Strabo were pointed out as being due to the Leleges, have seemingly been identified by modern travellers on different points of the Carian coast. A few, simple in construction, belong to the neighbourhood of Iasus. They are chambers built of schistose blocks set up exactly as they

¹ Herodotus, ii. 154.

² The Egyptian text reads thus: "To the life-giving Apis, Prâm interpreter" (SAYCE, *The Karian Language*, pp. 15, 35).

came from the quarry (Fig. 213), the larger units having been reserved for the ceiling. These chambers are, as a rule, half embedded in the ground, and vary in size according as they were to receive one or several bodies.¹

Towards the extreme end of the peninsula of Halicarnassus,

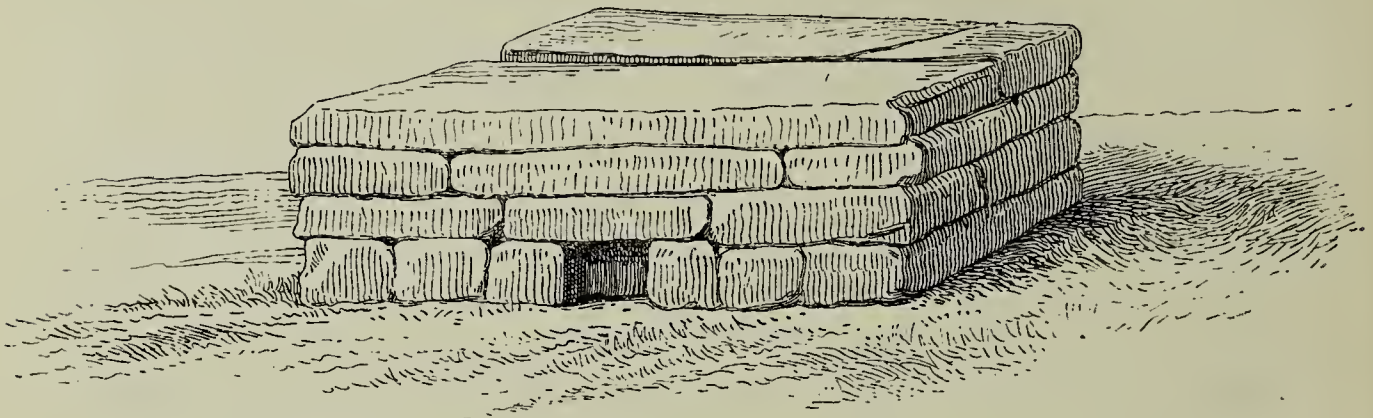

FIG. 213.—Tomb near Iasus. Téxier, tom. iii. Plate CXLVI, Fig. 8.

bearing to the southward, rises the Acropolis now called Assarlik ; and whether it corresponds to Syangela or Termera, there is no doubt as to its marking the site of one of those Carian or Lelegian cities whose importance, towards the fourth century B.C., gave way before Halicarnassus, one of the most flourishing centres of

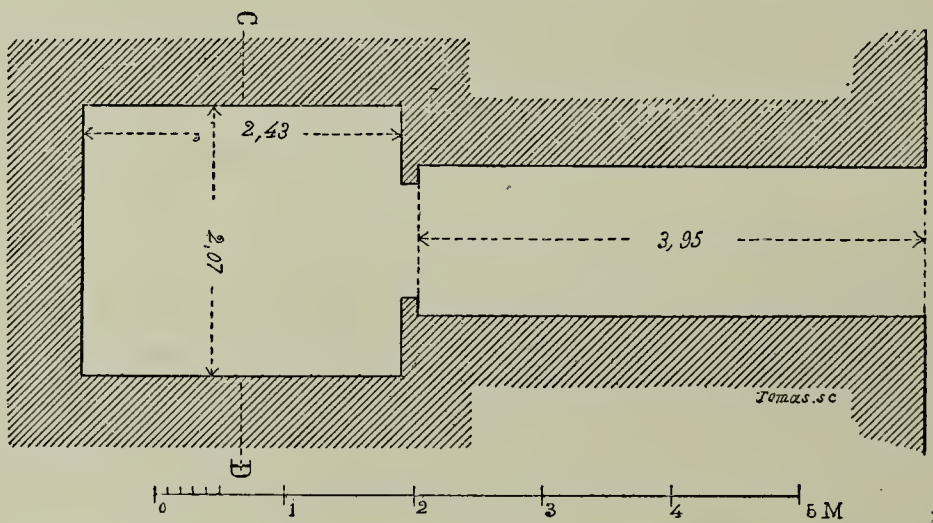

FIG. 214.—Tumulus at Assarlik. Plan. PATON, *Excavations*, p. 67.

Asia Minor, during the reign of Hekatomnos and his successors. Near the citadel is a necropolis of considerable size, which attracted the attention of Sir Charles Newton some thirty years ago,² and which has been more recently studied by M. Paton,

¹ TÉXIER, *Description*, fol., tom. iii. p. 141 ; explanatory of Plates, 146.

² NEWTON, *A Hist. of Discoveries at Halicarnassus, Cnidus, and Branchidæ*, p. 583.

who made excavations among the tumuli;¹ his drawings for the most part, however, are so imperfect as not to deserve reproduction.

Some of these tombs, commanding as a rule an elevated

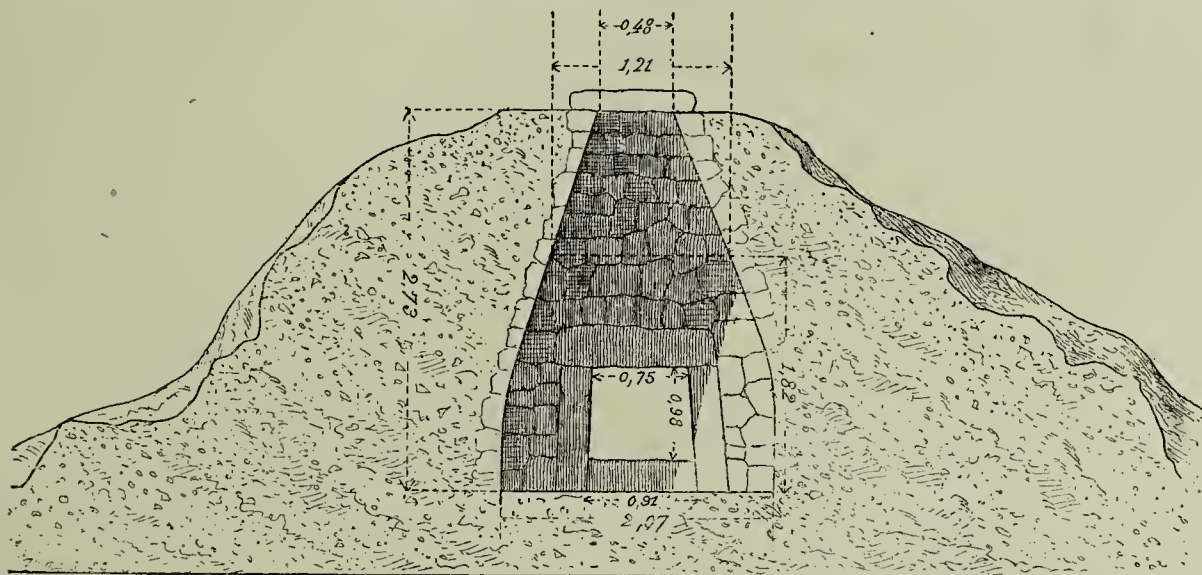

FIG. 215.—Tumulus at Assarlik. Transverse section. PATON, *Excavations*, p. 67.

position, belong to the tumulus-type, examples of which are so plentiful throughout Lydia. Thus, Fig. 214 shows a vault entered by a covered passage, roofed by large slabs; both it and the chamber are hidden under a mound made up of earth and

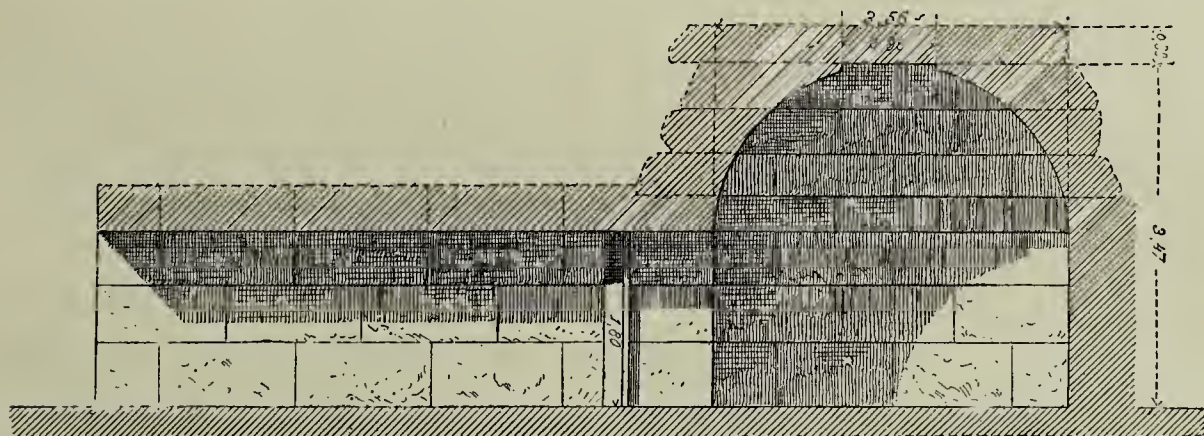

FIG. 216.—Tumulus at Gheresi. *Ibid.*, p. 80.

small stones. Above the grave-apartment the end stones of each course are corbelled out beyond one another, thus producing the effect of an arch (Fig. 215). In another of these tombs, which has had more care bestowed upon it, the hollow at the top was closed by an enormous stone, at least 4 m. 35 c. long (Fig. 216). A plan

¹ W. R. PATON, *Excavations in Caria* (*Hell. Studies*, tom. viii. pp. 64–82).

of the tumulus will be found in Fig. 217. But the circular wall that surrounds the mound at a distance, and forms a kind of sacred

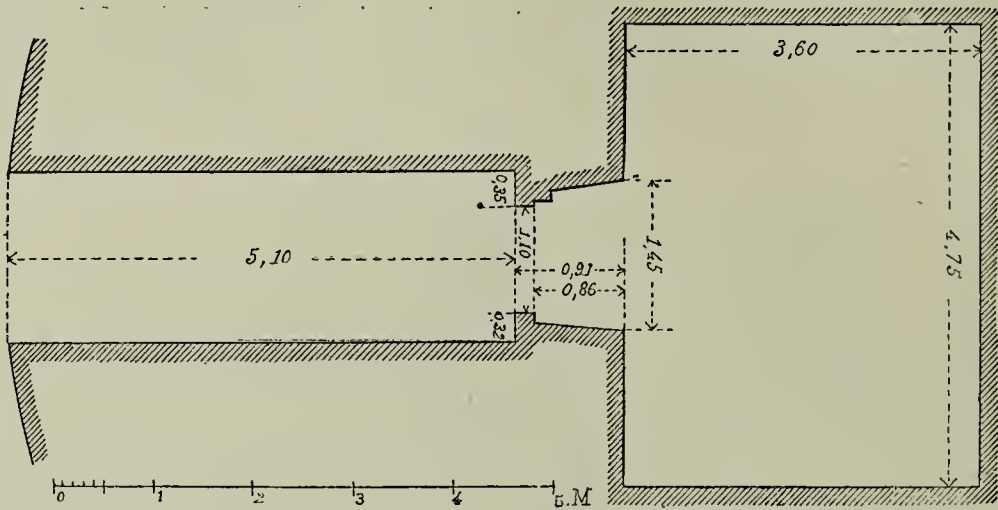

FIG. 217.—Tumulus at Gheresi. Plan. PATON, *Excavations*, p. 80.

area, is peculiar to these monuments and is never met with in Lydia (Fig. 218).

Of the vast majority of the tombs that certainly existed here, nothing remains but a low, ill-constructed wall of two or three irregular courses, which bounded the tumulus and upheld the mass. Lack of a casing to protect and support these walls is cause that the rains have penetrated the tumulus and carried down stones and earth, heaping them upon the ground.

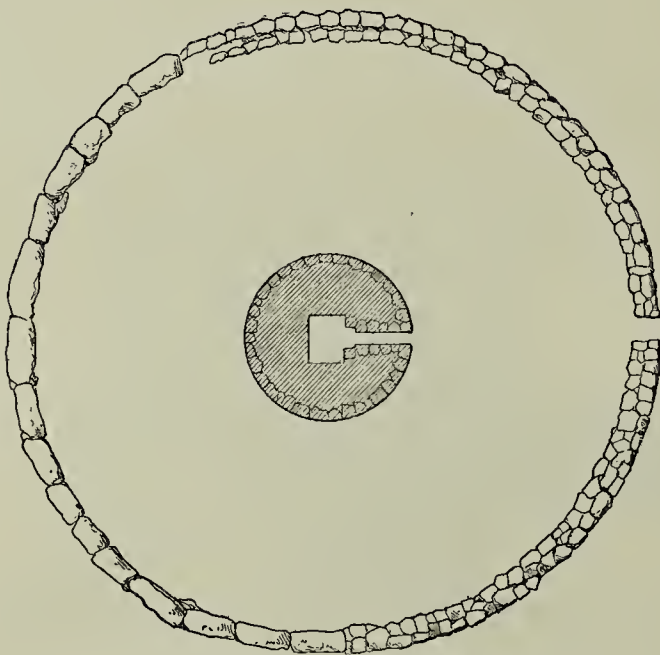

FIG. 218.—Tumulus with its circular wall.
Plan. *Ibid.*

The fact that no funereal beds have been found here, akin to those of Phrygia and Lydia, is pretty convincing proof that the Carians practised incineration.

The tombs in this necropolis were not all of the same size and on the same pattern, for, side by side with those of a certain importance, we come upon quite a large number of small, unpretending graves, mostly put within rectangular recesses which are fenced by a low wall. The tower-like structure

(Fig. 219) belongs to a necropolis some three miles southward of Halicarnassus. Its discovery is due to MM. Winter and Judeich. It is obvious that we are confronted here by a sepulchral *enceinte*, respecting which unusual precautions were taken to protect the dead against the living: instanced in several ditches surrounding it, as well as huge blocks set up around the graves, the larger stone being placed lintel-wise over the entrance. A doorway lower than this appears at the further side; the wall out of which it opens is built of stones of the smallest pattern. It may be modern, and have been used to pen cattle.¹ The

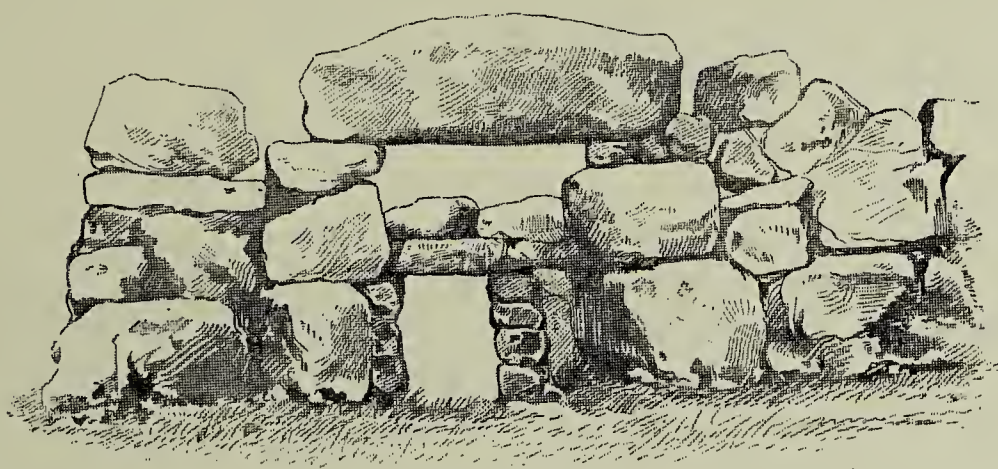

FIG. 219.—Funereal enceinte. Caria. *Mittheilungen*, xii. p. 225.

tombs found within *enceintes* of this description were mere hollows, and recall those at Iasus; they are fenced round now by huge tiles, one for each side, now by the same number of stones. A larger unit, rounded and flattened towards the edges, serves as lid. Such contrivances are no more than boxes, some 30 c. wide by 45 c. Bodies could not lie at length in them. They were meant to receive the ashes of the dead, which have been found either on the bare earth, more often in a terra-cotta vase, a large pithos with pointed base. Nor were urns the only pieces of furniture about these tombs; smaller vases of more varied shape, arms, and personal ornaments are often met with, both within the vaults of tumuli and the receptacles sunk in the surface of the soil.

¹ WINTER, *Vasen aus Karien*, pp. 224, 225; in *Mittheilungen des K. d. Instituts, Athenische Abtheilung*, tom. xii. pp. 223, 224.

RELIGIOUS AND MILITARY ARCHITECTURE.

The temples of Caria, as those of Lydia, were all rebuilt after the fourth century B.C., on the actual sites of the primitive ones. The public ritual which had marked the old religion was continued without a break in the new buildings; so that they retained, for example at Lagina, a very distinct physiognomy. At the present day, however, all that remains are Corinthian and Ionian capitals of mediocre workmanship, fragments of friezes carved by second-rate Greek artists; in which dry, finicky make are the distinguishing features, as indeed in all buildings erected by the successors of Alexander and the Roman proconsuls.¹ These unlovely *débris*, which commonplace ornament does nothing to redeem, may perhaps conceal remains of primal structures which excavations, that should go deep enough, would bring to light; when, who knows but that we might come upon ex-votos that Carian soldiers had offered to their "god of hosts," or their Zeus Stratios, on their return home after the many adventures and hardships they had experienced with Psammeticus, in his distant campaigns up the Nile as far as Nubia, or the expeditions Alyattes and Cræsus had carried across the Halys, against Medes and Persians? *Per contra*, on the crested heights where the primitive inhabitants built their first cities, more than one wall fragment is seen with no resemblance to Hellenic work.

If there is a monument more likely than another to tempt one to seek in it a very old specimen, such as popular fancy, in the day of Strabo, connected with the early owners of the soil, it assuredly is the singular rampart discovered by Têxier near Iasus, and which he calls "Leleges' Wall." Its length is several kilometres; and its trace on the mainland is within a certain distance of the shore, and contiguous to the islet bearing the Greek city; it runs over a broken uncultivated tract, without trace of habitation. The fact that the defences, towers, and resaults of the wall under notice are turned towards the sea, forbids seeking in it advanced works of the Iasians to protect their suburbs against invasions from the interior. The notion that it was intended to cover the territory of a city on the main-

¹ As regards the remains of the temple of Lagina, see NEWTON, *A Hist. of Discoveries*, Atlas, Plate LXXVII.

land, to prevent a landing, which city may have been Miletus, whose southern limit joined on that of Iasus, would seem to be the more likely, but for the other fact that this formidable rampart could be attacked on another point of the gulf, and taken from the rear. Consequently we are left to wonder why so great an effort should have been made for so small and uncertain a result. Moreover, the dispositions exhibited in the trace of the wall are very dissimilar from those of Greek fortifications (Fig. 220); nor does the masonry, in which stones of enormous calibre and

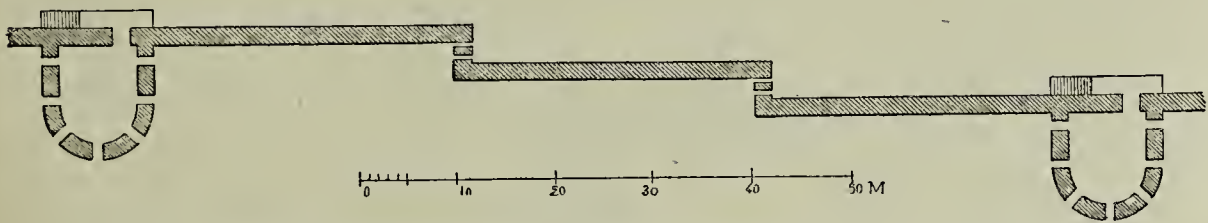

FIG. 220.—Plan of the Leleges' Wall. TÉXIER, *Description*, tom. iii. Plate CXLVII.

irregular courses obtain, in any way resemble that of structures of the Argian colony at Iasus, for example, the continuous rampart set up around their islet. The latter, along with its square towers, is built of great blocks of white marble, "bossed," 70 c. in height;¹ whilst the outer face of the wall on the mainland is barely touched by the chisel (Fig. 221). Téxier was the first to draw attention to the Leleges' Wall, to call it by the name he gave it, which well deserves to be studied with more care than it has as yet received; and it is matter for surprise that, of the many travellers who have visited Caria since the French explorer, not one should have responded to the appeal he directed to his successors.² It is just

¹ TÉXIER, *Description*, tom. iii. p. 137. In respect to the Greek city of Iasus, see E. L. HICKS, *Iasus* (*Hell. Studies*, viii. pp. 83-118).

² The architect Huyot, and after him Alexandre and Léon de Laborde, had visited Iasus before Téxier; the result of Huyot's researches were not given to the world. Made aware by a passage of Laborde (*Voy. de l'Asie Mineure*, fol., p. 93) of the interest of Huyot's notes and drawings deposited in the Manuscripts Cabinet of the Bibliothèque Nationale, I lost no time in consulting them. They are headed: "*Notes d'un voyage de Paris à Smyrne, 1817-1821, autographe, Fonds français, nouvelles acquisitions, 664; 2 vols. in-fol., de planches 5080, 5081.*" No sketch of the wall on *terra ferma*; but the problem propounded by the gigantic construction seems to have excited Huyot's curiosity, as will appear from his own words, p. 236: "On the mainland, on the other side of the small harbour, skirting the seashore, runs a low mountain chain. A long wall, with towers flanking it on the land side, descends, ascends, and runs out to a considerable distance. Main entrance in the valley. Facing the gate, a platform upon which may have been a temple. This wall is a stupendous structure which embraces nothing but bare rocks, and no trace

possible that, were a complete tracing of the rampart made, some sort of guess might be hazarded as to the intentions of the forgotten authors of a work which, though rude, they endowed with a certain degree of grandeur by sheer massiveness and extent. The towers, distributed over the length of the rampart at about



FIG. 221.—Gateway in the Leleges' Wall. TÉXIER, *Description*, Plate CXLVII.

100 m. one from the other, form a semi-circular salience over the curtain (Fig. 222); their thickness, at the height of the window, is 4 m.; that of the wall, 3 m.; and the height of the courses averages 1 m. (Fig. 223).

of other buildings, nor would it have been possible to erect any save within a few narrow corners. Nevertheless there must have been here a large population. The construction of the wall is good. At stated intervals are round towers, furnished with small doorways. Between the towers, results and the same kind of openings. Both gates and results seem to have been provided for the double purpose of facilitating sorties and preventing the enemy approaching the wall. Here and there, pierced towards the top of the wall, are openings level with the ground on the city side, but at a considerable height towards the plain."

The wall of another Carian city, Alinda, whose ruins cover a considerable area, should be noticed. "The towers which flanked the rampart of both Acropolis and city are almost entire. They

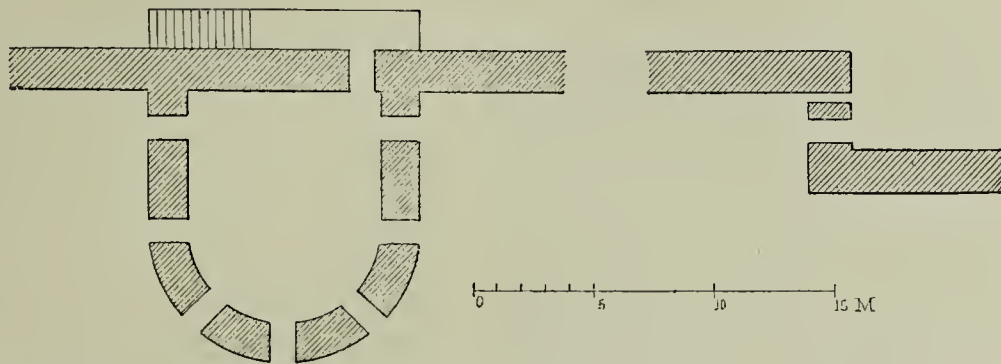

FIG. 222.—Leleges' Wall. Plan of tower and adjacent rampart. TÉXIER, *Description*, Plate CXLVII.

were provided with banquettes and loopholes for the defence. Above them, on a peaked rock that dominated the town and even the Acropolis, rose a fortified tower, whose function was to guard

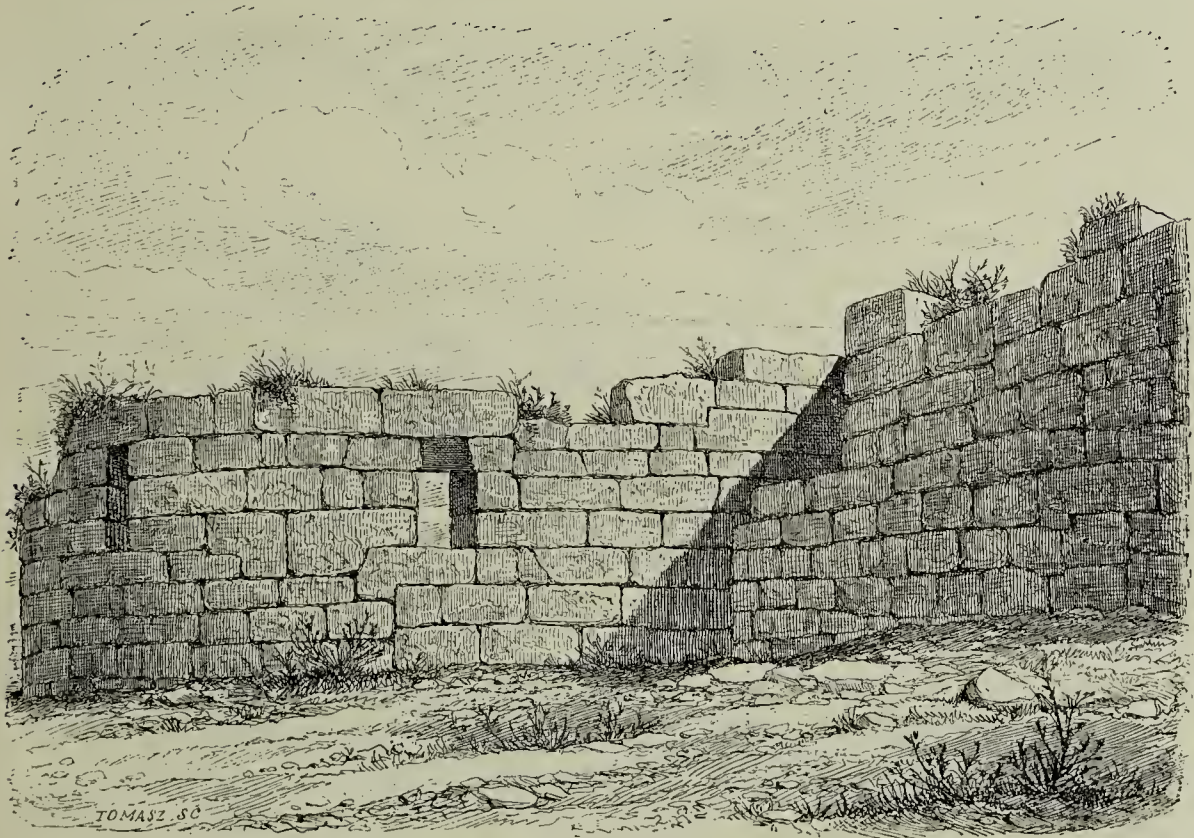

FIG. 223.—Leleges' Wall. View of tower. *Ibid.*, Plate CXLIX.

so important a point."¹ Fig. 224, after M. Trémaux' plan, shows the direction of the wall and the towers distributed about it. It will be observed that its most oblique course is from the first to

¹ TRÉMAUX, *Exploration arché. en Asie Mineure*, fol.

the second tower, planted on the culminating point of the Acropolis.¹ Farther on, in front, appears a detached tower, a phrourion (guarded post) (Fig. 224).

The city wall at Assarlik, of which Sir C. Newton made a drawing, offers pretty much the same aspect as that near Iasus;² there is great tendency to regular courses and vertical joints. It is probable that we have here the most perfect style of masonry achieved by the primitive inhabitants, ere they put themselves under Greek tuition; whilst their first constructive attempts may be sought in a wall of this same district. It runs along the rock that forms the crest of

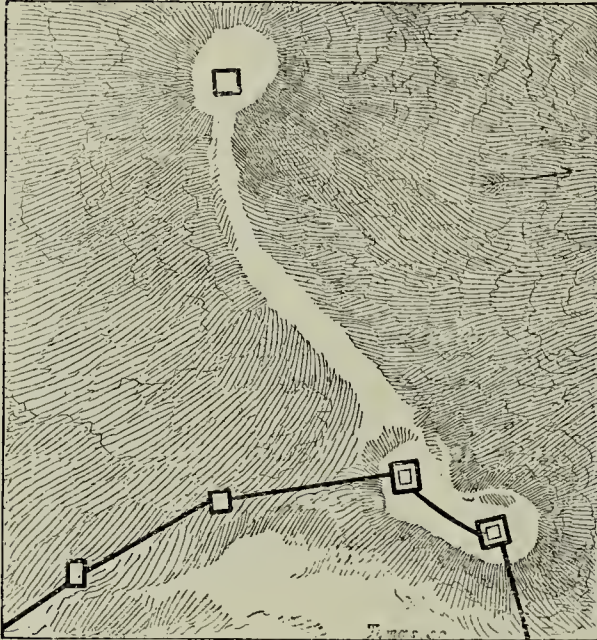

FIG. 224. —Portion of plan of Alinda.



FIG. 225.—Wall near Myndus. PATON, *Excavations*, p. 66.

the peninsula, west of Myndus harbour, and descends to the sea edge (Fig. 225).

¹ Cf. PHILON, *Traité de fortification*, viii. 6 and 13, in the translation of M. de Rochas d'Aiglun, *Principes de la fortification antique*, 8vo, Duchar, 1881.

² NEWTON, *A Hist. of Discoveries*, pp. 503-586.

It would be vain to multiply examples of this kind; those we have cited suffice to show that if the Carians and Leleges were not solicitous, as only the Greeks have been, to impress upon whatever work came from their hands, even to a simple wall, a mark of beauty and grace, they nevertheless knew how to use materials of such size and solidity, as to have withstood the neglect of thousands of years.

INDUSTRIAL ARTS.

The physical formation of Caria is very similar to that of Lydia, and potter's clay of equally excellent quality is plentiful; hence, one of its towns, Tralles, was famous for its pottery, which it largely exported.¹ Pliny wrote that in his time the brick palaces of Attalus and Mausolus were still standing; the former in this same city of Tralles, the latter at Halicarnassus.² Recent excavations have confirmed the testimony of the Roman writer; they have proved that baked clay was applied in this district to many and diverse uses—that they were not content to fashion vases of every size and shape for domestic purposes, but had their coffins made out of it as well. Thus, within recently explored necropoles, we sometimes find ashes in large clay jars ending almost in a point below, and at other times in chests or sarcophagi of the same substance.³ But whether these vases were put within jars and sarcophagi, or set in the tumulus-chamber or the grave against the coffin, a sufficient number has been found to enable us to gain some idea as to the habits and taste of the Carian potters.

As in Lydia, the clay is a rich reddish yellow, fine in texture and well prepared. The lightness of the handles and the variety of types show that the artisan was already proficient in his craft. The vast majority of vases were decorated, and the form is obviously meant in those whose surface is covered with a coating of a dark brown pigment; such would be a kind of bowl which, along with other vases, came out of a necropolis hard by Tshangli, near, it is supposed, the ancient site of Panionion (Fig. 226). Most of the pieces have ornamental designs, composed of ring-

¹ PLINY, *Hist. Nat.*, xxxv. 46.

² *Ibid.*, 49.

³ W. R. PATON, *Excavations in Caria*, pp. 70, 73, 75-79; F. WINTER, *Vasen aus Karien*, pp. 226, 227.

like bands turning round the body (Fig. 227); the lines sometimes intersect concentric circles that are parallel to the main axis of the vase (Fig. 228); sometimes, in the blank spaces about the

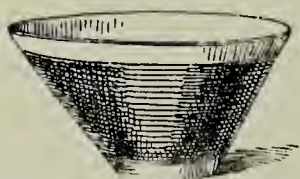

FIG. 226.—Carian pottery.
Winter, p. 229.

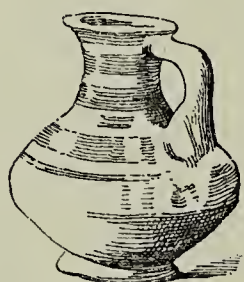

FIG. 227.—Carian pottery.
Ibid.

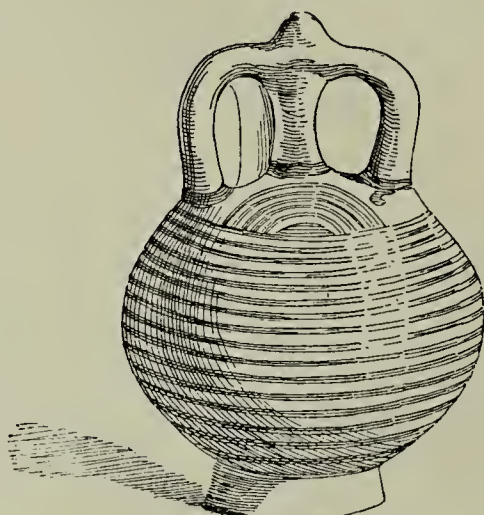

FIG. 228.—Carian pottery. Paton,
p. 74.

middle, we find triangles whose apex is turned towards the neck (Fig. 229); whilst the spiral device, that distinguishing feature



FIG. 229.—Carian pottery. Winter, p. 229.



FIG. 230.—Carian pottery. *Ibid.*, 230.

of Mycenaean ornament, appears upon a vase now at Smyrna, and which is said to have come from Mylasa (Fig. 230).

The decoration of these and other pieces of the same nature is purely geometrical; nevertheless we have indications that the

Carian artist sometimes aspired to a higher standard, in at least two vases of the same fabrication, wherein are introduced shapes borrowed from the living world.¹ They came out of a tomb near Idrias, where they had lain along with human ashes in a huge funerary jar, resembling at all points the examples of the Assarlik necropolis. To name them in their ascending scale, the less important is a two-handled bowl (Fig. 231). The band below the rim stands out in light against the dark ground, and between the vertical bars, dividing it into a number of panels, the brush has traced roughly suggested birds. These, though imperfectly seen in our illustration, thanks to the bits of colour that still adhere to the piece, are quite distinct in the original. The second vase is

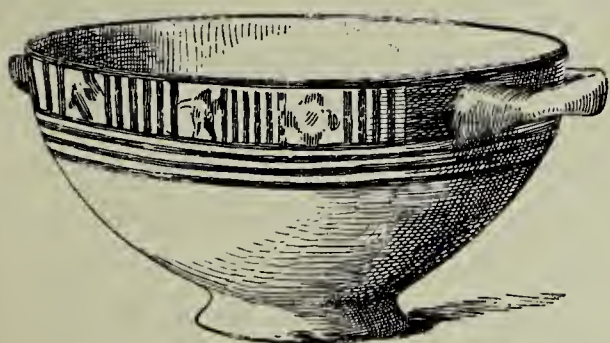

FIG. 231.—Vase from Idrias. Winter, p. 226.

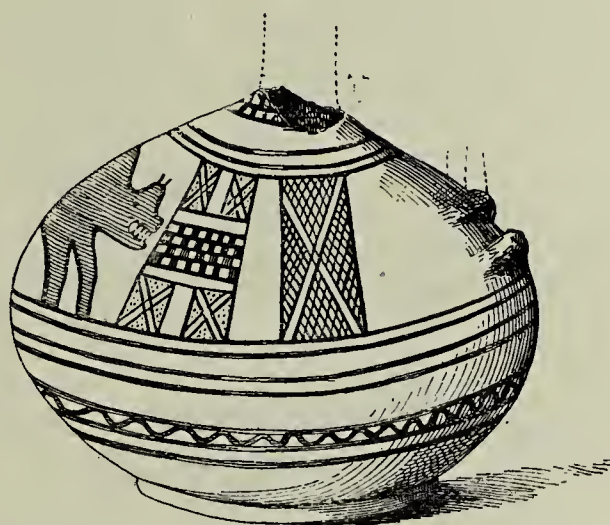

FIG. 232.—Vase from Idrias. *Ibid.*

exceedingly curious. It has a very protuberant contour, but its long narrow neck and handle are broken (Fig. 232). The markings of the latter are plainly seen on the body.

The decoration consisted in part of bands, turning round the body at irregular intervals; but a more complicated arrangement than any from the same workshop is found in the lines that appear in the centre (Fig. 233). The meanders and oblique lines cross each other at acute angles, and form triangles, the surface of which is now sprinkled with dots, now taken up with fine trellis-work, now with the checker-pattern, which we observed in Cyprus, and which likewise occurs on countless Greek vases of the archaic period. The special interest which attaches to this piece is the figure introduced at the side of the

¹ WINTER, *Vasen aus Karien*, pp. 226, 227, 232-234.

ewer, opposite the handle. Though roughly outlined, the double row of pointed teeth is distinct enough to suggest a carnivorous and ferocious animal; as to the genus to which it belongs, it would be hard to say. The lion is out of the running; his physiognomy was too familiar to make it possible for any Oriental artist to have so disfigured it. Stress is laid by some on the hump which appears on the back, and which is proper to one kind of bull as well as the bear; the teeth of the former, however, are not nail-shaped, but large and flat. At first sight, there would seem to be a greater degree of probability in recognizing here a Bruin, an animal found in the Taurus range at the present day, and which formerly may have haunted the then well-timbered ravines of Tmolus and Latmos. There is nothing to forbid the conjecture; yet certain details, the disposition of the teeth, length of tail, and elongated body, ill agree with the bear hypothesis;

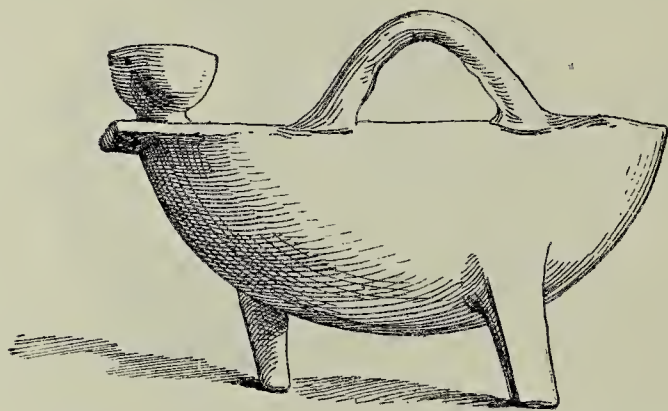

FIG. 234.—Carian pottery. Paton, p. 74.

but if we suppose that the unskilful artist intended to portray a hyena, all difficulties would seem to vanish. Thus, when moving, the hyena arches her back as in our illustration; nevertheless, it is hard to explain that if a hyena was indeed meant, the artist should have omitted to in-

dicating the characteristic and abnormal length of the fore-legs of the animal, that make it look when at rest as if standing on its hind legs.

The pigments used in the decoration of these vases are of that dull opaque colour encountered on very antique Greek vases. Here black and white bands stand out on a light-yellow ground; there the form is painted in with a brownish-red colour. In the largest specimen (Fig. 233), the form is in three tones; the lines are dark violet, the animal and the bands round the body brick-red, whilst the dots scattered over the field of the triangles are light green. Colours of this kind were not fast, and are easily rubbed off; so that great care has to be exercised in cleaning the pieces. The shapes are generally very simple, and not devoid of elegance; that of the three-footed specimen, with a single



FIG. 233.—Vase from Idrias. Showing detail of ornament. Actual size. Winter, Plate VI.

handle at the side and spout in front, recalling the aspect of a lamp, is somewhat more complicated (Fig. 234). Medium-size or small vases were hand-painted; whilst the large jars and the slabs, out of which sarcophagi were made, had the ornament stamped in, impressed on the wheel whilst the clay was wet and soft. Spirals (Fig. 235) that remind one of the stelas at Mycenæ, chevrons, and a rudely chalked-in ovolo device are the due accompaniment of pithoi (Fig. 236). As to the slabs of terra-cotta that formed the walls of the sarcophagi, besides the usual meander, we find rosette devices very similar to those seen on Mycenaean pieces of jewellery (Fig. 237). Of these, the simplest is a star composed of eight rays or bars (Fig. 238). Elsewhere it has but six points, but the intervening space is filled in with the tooth device (Fig. 239). A decided step in advance is observable in the ornament of the two remaining



FIG. 235.—Fragment of pithos.
After Paton, p. 71.

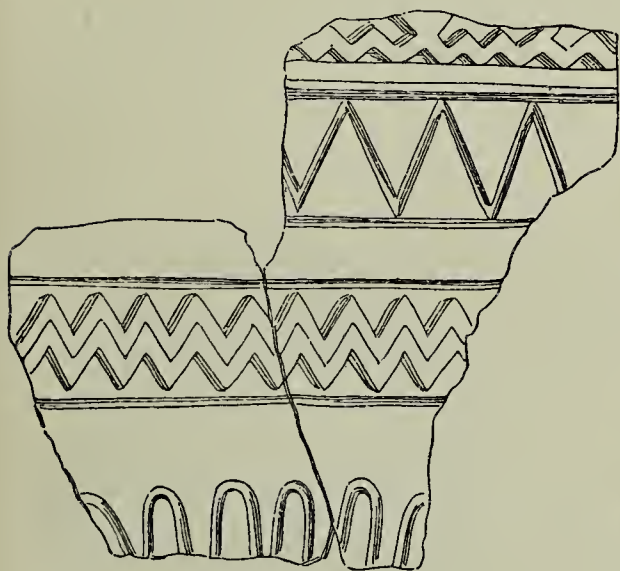

FIG. 236.—Fragment of pithos.
Ibid., p. 79.



FIG. 237.—Slab from sarcophagus. One-fourth of its actual size. *Ibid.*, p. 75.

slabs. In the one two zones of chevrons, frankly separated by concentric rings, surround the central star (Fig. 240). No star appears in the other, the space being wholly taken up by the willow pattern, which is made to radiate around a central ring, and is intersected by five presiding lines, dividing the circle into six

equal segments (Fig. 241). The arrangement of the rosettes is felicitous. As we observed before, it proves that the artist was no mere tyro, but one who could skilfully handle the elements of design to decorate his surfaces.

The remark holds good in respect to the indus-

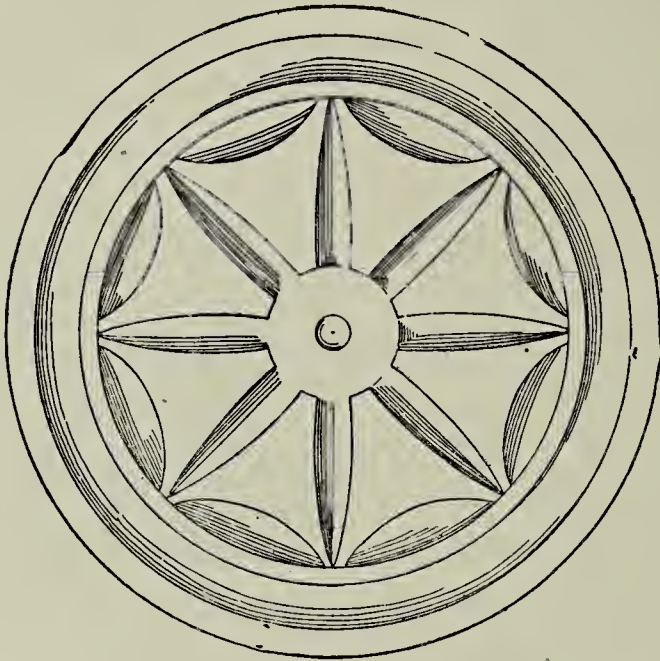

FIG. 238.—Slab from sarcophagus. One-fourth of actual size. After Paton, p. 76.

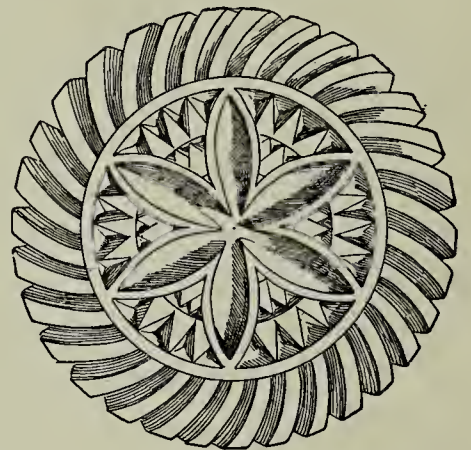

FIG. 239.—Slab from sarcophagus. One-fourth of actual size. *Ibid.*, Paton, p. 75.

trial objects that have been found in the Assarlik necropolis. They are fragments of gold twist, of which one was a light ring; and plaques of the same precious metal, with very simple



FIG. 240.—Slab from sarcophagus. One-fourth of actual size. *Ibid.*, p. 75.

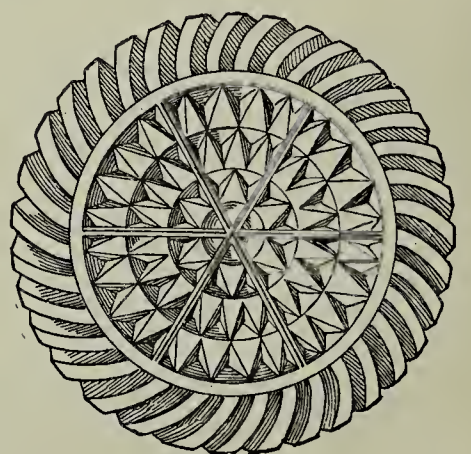

FIG. 241.—Slab from sarcophagus. One-fourth of actual size. *Ibid.*, p. 77.

ornament made up of lines beaten out. A specimen shows a hole at both ends, large enough for the passage of a very slender nail or thread; hence it could be applied or sewn on to a

garment.¹ Bracelets, spirals, and bronze fibulæ are not rare. The only specimen which is intact will be found at Fig. 242.

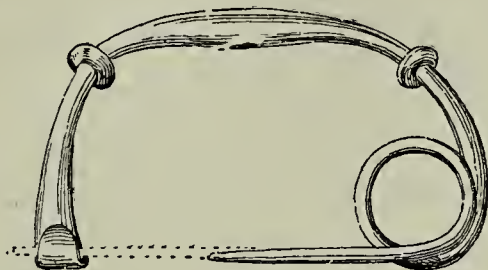

FIG. 242.—Bronze fibula. Actual size. After Paton, p. 74.

On the other hand, defensive arms, spear-heads, knife-blades, with point often twisted, are all of iron.

GENERAL CHARACTERISTICS OF CARIAN CIVILIZATION.

We have endeavoured to give as complete an inventory as possible of Carian culture, but the results we have reached are far from satisfying our curiosity. Nevertheless we will point out the most salient features, such as are likely to linger in the memory.

The constructive methods of the Carians had nothing to distinguish them from those of the other nations of the peninsula. Like these, the materials they employ are varied, and are the natural outcome of the progress of time and advance in manual arts. To walls built of roughly squared blocks there succeeded others in which units were still put one upon another without mortar, with courses more or less regular, precisely as in Cappadocia, Phrygia, and Lydia. On the other hand, the arrangement observable in the sepulchral architecture of Caria is also met with in Lydia, but nowhere else. Both south of the Mæander and in the valley of the Hermus, the shape to which preference is given in tombs of some importance is the tumulus type, along with a covered passage and internal chambered grave. There is another correspondence: owing to the superior quality of their clay, Carians and Lydians alike largely built in brick, and were noted for their skill as potters. The resemblance between fragments of vases collected in the royal necropolis at Sardes with those that came out of Carian sepulchres is truly remarkable. Forms and colours are identical, and the principle applied to the

¹ PATON, *Excavations*, pp. 68 and 70, Figs. 7, 11-13.

ornament is the same in both. True, a couple of vases have been picked up in Caria which testify to the effort the artist made in order to step beyond a simple combination of lines, and draw his inspirations from living nature, whilst Lydian ceramic industry affords no example of so ambitious an aim. This, we maintain, is purely accidental: a lucky hit which attended on the Carian excavations. In fact, it would be preposterous to assume that what was achieved at Idrias and Mylasa was impossible in a capital such as Sardes; the more so that the same taste and the same methods obtained throughout the south-western part of this region. The remark applies in full to jewellery. Thus golden plaques, hammer beaten, have been found as plentifully in Caria as in Lydia, proving, moreover, that here as there the precious metal was put to the same uses. The human and animal form appear only on a brace of vases that were dug up with others at Tralles; all the specimens from the environs of Halicarnassus have no other than geometric forms. The only sensible conclusion to be drawn therefrom is that certain pieces were more elaborately wrought than others, and that forms of a higher order were selected for the decoration. On the other hand, it should be borne in mind that Tralles stands on the border between Lydia and Caria; hence the personal ornaments that have been brought to light there may be carried to the account of either indifferently. If we have assigned them to Lydia, it was because their elegance and richness awoke in our mind the remembrance of the proverbial opulence tradition ascribed to the subjects of Cræsus.

No traces of sculpture have been discovered in Caria or Lydia. Some authorities hold that the lacuna could be easily filled up. Not a few of the archæologists who have busied themselves with the origins of Grecian art are inclined to attribute to the Carians those tiny, shapeless statuettes that are found in vast numbers in and out of the Cyclades (Fig. 243).¹ According to them, such pieces are the work of the Leleges and the Carians, and date from those far-off days when these people sailed over the Ægean in every direction, and peopled its islands and the coasts of Peloponnesus as well. We will confine ourselves for the present to the following prejudicial remark:—Cappadocia, Paphlagonia,

¹ Tiesch was the first to broach the notion ("Ueber Paros und Parische Inschriften" in *Abhandlungen der Muenchener-Akademie*, 1834, p. 585, P. A.). Cf. L. Ross, *Archæ. Aufsætzte*, tom. i. p. 855; *Vorgriechisches Græber*, pp. 52, 53.

Phrygia, and the region of Sipylus offer countless rock-sculptures to the gaze of the traveller, but not one instance has been reported from Caria. The excavations that have been made in the Carian necropoles have yielded naught beyond vases and jewels; small figures, whether of stone, bronze, or terra-cotta, that might in any way remind us of the primitive statuettes of the Archipelago are non-existent. To admit that the Carians fabricated the figures in question, we must suppose that they did so before they migrated to Asia Minor, since

as soon as they were in possession of the province that goes by their name, contact with the Phrygians on the one hand, and the Lydians on the other, was a daily occurrence. The art of these was sufficiently advanced to serve as model to the Carians, who then ceased to reproduce types puerile and barbarous in the extreme, when the same order of ideas prompted them to adopt the tumulus-type as mode of entombment—a type absent in the Archipelago, but of which multitudinous specimens exist in Lydia. The hypothesis is a fascinating one, and has the merit to remove many difficulties; its greater or less degree of probability, however, is dependent on ulterior discoveries which should reveal monuments in Asia Minor akin to the oldest tombs of the Cyclades. Then, and only then, we should be in a position to follow the track of this restless wandering people, even as we followed that of the Phœnicians, from their native coast of Palestine on to those of Spain; then only would it be legitimate to recognize in the incipient fabricators of these coarse idols the primeval inhabitants of the Greek islands on the one hand, and on the other the ancestors of those Hellenes who, in the day of Homer and afterwards, occupied the region south of the Mæander. Until this comes to pass the question under notice must at least remain doubtful.

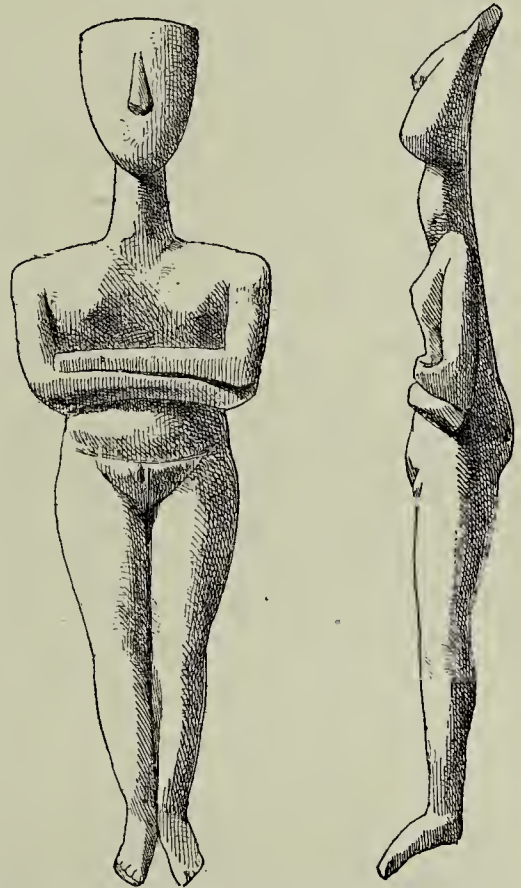

FIG. 243.—Stone statuettes. Actual size. LE BAS, *Voyage Arché.*, "Monuments figurés," Plate CXXXIII.

On the other hand, if we maintain a prudent reserve, and give up attempting to reach the cloudland where the insular Carians are lost to our gaze, if we forbear crediting them with works which tell us nothing as to their authors, it will simplify matters not a little, in that it will leave nothing more than a stay-at-home people, with a language and religion closely allied to those of the Lydians, from whom they are henceforth (the sixth century B.C.) inseparable. Nevertheless, the situation of many of their centres within deep bays, or at the extremity of jutting headlands, as well as their worship of a sea-god, whom the Lydians knew not, distinguished them from the latter. Then, too, even after the loss of their autonomy they still retained something of their wandering habits, which they satisfied by enrolling themselves as mercenaries and 'dragomans'; in which capacities they visited Syria, and especially Egypt, where many remained in respectable positions. Such expeditions imply voyages from the Nile valley to that of the Mæander, and during one of these, perhaps, the Carians may have carried to Lydia the pieces of jewellery found at Tralles. The fact that their love of adventure and turbulent disposition lived with them even when they inhabited cities they had raised, along with temples in close proximity to the necropoles in which their dead reposed, is confirmatory of the legend that told of the part played by the Carians in pre-historic times, and of their maritime sway.

The historian is thus brought round to an hypothesis from which at first his prudence recoiled, and which he now refrains examining in detail until the day when he shall be in a situation to compare on the one side the monuments collected in the Cyclades with those dug up at Hissarlik and Thera, and on the other hand the instances representing the culture of Mycenæ.



LYCIA.



CHAPTER I.

THE LYCIANS—THEIR COUNTRY, HISTORY, AND RELIGION.

THE COUNTRY.

LYCIA is a country of Asia Minor, bounded on the south by the Mediterranean, Caria, and the deep gulf now called Macri on the west, Pamphylia and the open roadstead of Adalia on the east. Its line of coast towards the south is nearly as marked as that of Cilicia, Tracheia or the rough, and is constituted by the powerful spurs which Taurus throws out in this direction. Their broad base covers the whole surface of the province, and in antiquity each mount had a particular name. From west to east was, first, Anticragos, which rose high above Telmessus (Macri); and Cragos, a mere prolongation of the first, stretching close up to the sea, where it terminated in formidable escarps. Then came Massikyτος, some of whose numerous peaks rose far above those of the mountains along the coast, being more than three thousand metres in height, that is to say, the region of everlasting snow.¹ It is now called Ak-Dagh (Mont Blanc), and, like this, is the central knot of the somewhat complicated system of the mountains in which it stands. It is connected with Mount Solyma by the Susuz-Dagh; but Takalu-Dagh, to the south-westward of the province, in the rear of the ancient site of trading Phaselis, reaches an altitude of two thousand four hundred metres; further north, the long ridge of *Klimax* (the "Ladder") leaves no more than

¹ The snow disappears on the southern slopes during the months of July and August, but it remains throughout the year on those looking north.

a footpath between its precipitous sides and the sea, which disappears under the flood as often as a sea wind prevails. In Mount Solyma is seen the subterraneous fire which gave rise to the fable of the Chimæra;¹ the shepherds round about utilize the flames that leap out of a slit in the rock to cook their dinner.

Lycia can boast of but one valley really deserving the name, open enough and spacious enough to have been split up into several divisions, each with an important centre embosomed amidst gardens and well-watered fields, which covered the gentle slopes of the last counter-forts of the mountain towards the plain, and supported houses, public edifices, and acropolises. The valley is known as Sibros or Xanthus (Eshen-Tshai) (Fig. 244); its length from the sea where it abuts to the rocky gully out of which the river escapes is about fourteen leagues; its mean width is from three to five kilometres, whilst its direction, in a straight line from north to south, affords the shortest and most convenient route to those making their way inland. The other valleys of Lycia, —Myros (Dembre-Tshai), Arycandos (Bashkoz-Tshai), Limyros (Alaghir-Tshai)—are little more than gaps hollowed out in the rock by water agency. Flat level is seldom found except at the mouth of streams, where a narrow strip exists between the sea and the heights, due to the deposit of ages. Then, too, higher up the mountains, dominating numerous havens formed by the indentations of this jagged, rugged coast, appear here and there levelled spaces, just broad enough to afford a foothold to man between the escarpments of the cliff and the gentler slopes, which he covered with vineyards and fine plantations of olive. As time went on lack of room induced him to utilize the tiniest eyelets, lost in the depths of the mountain—such as Phellus, for example. Beyond the snowy peaks eastward of Xanthus, which the traveller descries from the sea, the aspect changes, for here vast plateaux with a

¹ In regard to the orography of Lycia, and the correspondence to be established between ancient and modern denominations, we have relied on Kiepert's map, in *Reisen in Süd-westlichen Kleinasien*, fol., Vienna, tom. i.; *Reisen in Lykien und Karien*, described by Otto Benndorf and Georg Niemann, 1884, with forty-nine plates in photogravure and eighty-nine figures in the text, tom. ii.; *Reisen in Lykien, Milyas, und Kibyrtis*, published by Eugen Petersen and Felix Luschan, 1888, forty plates in photogravure and eighty-six figures. A much reduced copy of this same map will be found in *Geschichte der Lykier*, by Oscar Treuber (12mo, 1887, Stuttgart). The work is a brief but exact summary of the best-known writings bearing upon the geography and history of Lycia.

mean elevation of a thousand to twelve hundred metres¹ (Fig. 245) stretch away to enormous distances. Properly speaking, however, these uplands no longer belong to Lycia.

The waters drained by these plateaux, after many a long winding,



FIG. 244.—Valley of Xanthus.² From the *Nouvelle Géographie*, by Elisée Reclus.

fall into the Mediterranean or spread themselves into inland lakes, whose overplus escapes through subterraneous abysses; but the

¹ The name geographers give to the plateau under notice is Elmalu, from a bustling modern town, the largest and most important in Lycia.

² The names of ancient towns in this and the next chart (Fig. 245) are more lightly marked so as to distinguish them from modern centres.

high plains themselves are allied to those of Cabalia, of Cibyratides, and of Southern Pisidia, which they continue with hardly any change of level, whilst on the Mediterranean side they are reached by long steep ascents and passes closed during the winter months. Lycia, on the contrary, is well timbered throughout, so that it offers little opportunity for the raising of corn. The lower slopes are covered with green patches of maple and fine oaks (*Quercus ægilops*), and towards the bottom of the valley torrents disappear

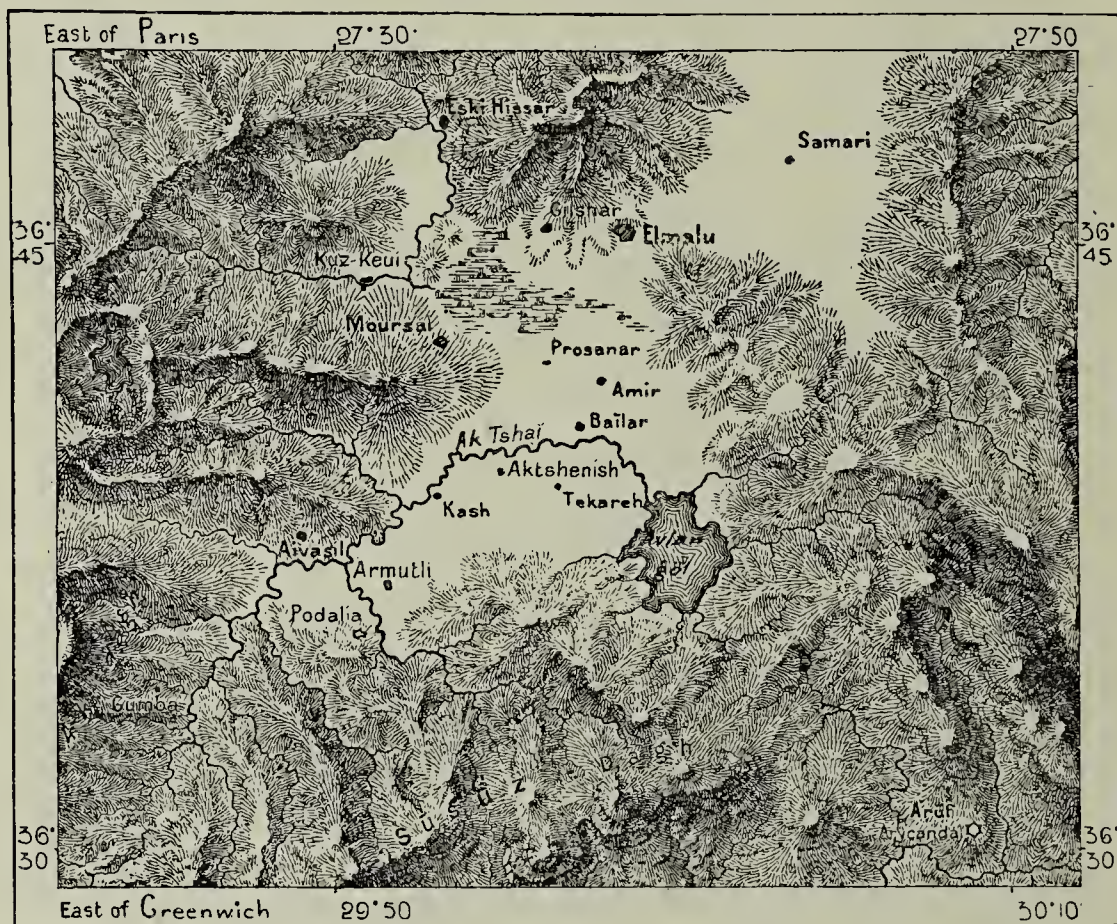

FIG. 245.—Plateau of Elmalu. After the *Nouvelle Géographie* of Elisée Reclus.

under the wide-spreading branches of planes which form a perfect arcade over them, and, as you follow the trend of the coast, high up in the flank of precipitous cliffs, out of every fissure in the rock are pines, which look as if suspended in mid air. Farther inland they appear in great clustering groups. And higher up still, in the vicinity of snow are met trees of a different kind, such as delight in cold—dark zones of firs and the yet gloomier cedar. Thus it will be seen that forests, which in many other parts of Asia have been utterly destroyed, here have battled with success against the neglect and waste of centuries.

One of the distinguishing features of Lycia, is the marked con-

trast of climate and the variety of vegetation which meet the traveller as he goes up the valleys abutting to the sea. Along the shore he sees none but lemon and orange groves, the monotony of whose line is broken by pyramid-like cypresses and tall feathery palms. A few hours' walk brings him to a colder zone, where the walnut, cherry, pear, and apple—in fact, all the trees of Europe—grow in abundance. A day of this continuous ascent amidst hill and dale, his ear caressed the while by the refreshing sound of the waterfall below, lands him in Alpine scenery, which vividly recalls Switzerland and Tyrol.¹ In such conditions as these, all that is needed to escape the extreme of heat or cold is a simple shifting of abode. The seasons, which here may be expected with the regularity of clockwork, give the signal for the start. Twice a year, spring and autumn, the whole population is on foot. Every lowland village owns, somewhere in the highlands, its *ayala*, or summer encampment, generally situated in the clearing of a forest or on its outskirts. Towards the end of May, all the roads are covered with the migratory population, driving before them their flocks and herds, when the stranger who happens to be travelling on these roads must needs stand aside many times in the day, to let them file past. All are eager to escape from the pestilential, burning shore, where every green leaf has withered under the scorching rays of the sun, to go and live three or four months in the cool atmosphere of the hills, near living springs, under the grateful shade of trees, where, too, their animals will find an abundance of grass. Even the most frequented ports are ere long abandoned by all except half a dozen or so of poor wretches, custom officers and shopkeepers, compelled by their professional duties or interests to remain; the former have to keep an eye over the sailors belonging to the ships stationed on the coast, whilst the latter are busy administering to their creature comforts. The example is catching, and more than one mountaineer forsakes his alpine hut for the plain, so that many villages in the higher uplands are deprived of part of their population during the winter months. A few possess on the seaboard a plantation of olives whose berries are ready to be gathered, or a plot of ground that needs sowing, whilst others will go on the farms as shepherds and journeymen.

¹ The distance, as a bird flies, between the spot where the Xanthus breaks through the rocky wall of the Cibyratides plateau, and where it reaches its lower valley, is but some ten kilometres; the difference of level, however, is eight hundred metres.

When the country was sprinkled with flourishing cities teeming with population, the Lycians must have been less prone to move from place to place than their descendants. Within the towns were buildings with very thick walls, roomy houses of great solidity, standing in shady gardens kept green by irrigation ; nor was the air along the shore rendered deadly by pestilential miasmas, rising from the harbours (as at Patara, for example), which now are turned into so many swamps. Hence, whether along the sea edge or in the towns of the lower valleys, a large proportion of the inhabitants were stationary. Nevertheless, habits such as these so naturally find their explanation in climatic exigencies as to make it difficult to imagine that they do not travel back, at least within certain limits, to antiquity itself.¹ The hills are everywhere so near the plain, the slopes so steep and rugged, that one and all of these tiny communities doubtless found within their own territory the needful summer station.

If climate and vegetation are not constant in Lycia, its physical formation, on the other hand, is pretty much the same everywhere. The breccia and facillite found in the lowlands were detached from the mountains above, and precipitated down there. Formations of schist and serpentine occur to the south-eastward, in the mountain chain that skirts the Bay of Adalia ; the rest of the thick mass is a calcareous stone, which shoots up into perpendicular walls above ravine and valley. Its degree of compactness varies in places, yet it lends itself everywhere to be cut with ease ; whilst its texture is fine enough and hard enough to have kept the shapes and inscriptions traced upon it by the chisel, infinitely better than the vast majority of the tufaceous rocks of Phrygia. Its colour is generally milky-white, like marble ; hence it is that travellers have often been deceived by its aspect, unmindful of the fact that no marble exists in Lycia. The rare monuments of that material encountered in the country are of foreign origin.²

¹ What makes one suspect that at that time social and religious existence was momentarily suspended, at least in the maritime cities, is a passage of Herodotus in reference to the oracle of Apollo at Patara, to the effect that he was silent during the summer months (i. 182 ; SERVIUS, *ad Æneida*, iv. 143). Again we read (Herodotus, i. 176) that when Xanthus fell to the hand of the Persians, eighty families were out of town (ἐτυχον τημικὰντα ἐκδημέουσαι)—a circumstance which suggests the idea that the households in question had left the city for their summer station before it was surrounded by the enemy.

² BENNDORF, *Reisen*, tom. i. p. 39.

The soil of Lycia is frequently agitated by earthquakes,¹ as the ruinous mass of more than one town amply testifies.² But for these seismic convulsions tombs and buildings would be intact; at least, in the vicinity of poor homesteads, whose inmates have no desire of re-using the materials of ancient structures. The thriving little town of Macri is a case in point; before many years are past the fine remains of ancient Telmessus will have completely disappeared in building new houses for the accommodation of the citizens of the modern centre.³

HISTORY.

There are good reasons for identifying the Lycians (Λυκοί) of classic tradition with the "Louka" of the Egyptian texts, where their name first appears in history, side by side with the Iliouna, the Shardhana, and the Shakalosh, those seafaring people whose repeated onslaughts carried terror into the heart of the Pharaohs of the nineteenth and twentieth dynasties.⁴ That which gives a high degree of probability to the above assumption is not dependent upon mere similarity of names, but rests on the fact that the tribes with which the Louka were associated in their campaigns against Egypt would seem to have likewise originally come from Asia Minor, where they have left traces of their transitory passage or long sojourn. There is but one difficulty in the way; to wit, the witness of Herodotus to the effect that the name the Lycians brought with them to the peninsula, that by which they were still known by their neighbours when he wrote, was not "Lycian," but "Termilæ" (Τερμίλαι).⁵ As a native of Carian Halicarnassus, whose bargemen certainly frequented the near ports of Lycia, Herodotus could not fail to be well informed. Nor is this a solitary assertion; other historical

¹ PLINY, *Hist. Nat.*, ii. 98.

² BENNDORF, *Reisen*, tom. i. p. 50.

³ Reference has already been made (*Hist. of Art*, tom. v. p. 323, n. 1) as to the monuments now disappeared, but which were standing when Huyot visited the ruins near Macri. Those interested in the subject will find the monuments under notice reproduced in a series of drawings covering eighteen sheets in his vol. i. of plates, which he never published.

⁴ DE ROUGÉ, "Extrait d'un mémoire sur les attaques dirigées contre l'Égypte par les peuples de la mer," in *Revue Arché.*, N.S. 1867, tom. xvi. pp. 39, 96, 97.

⁵ Herodotus, i. 173; vii. 92.

texts,¹ and the Lycian inscriptions themselves, bear the same testimony. These, though they do not lend themselves to being deciphered, have alphabetical signs whose value is known. Now, the word ΤΡΧΜΕΛΛ has been found in them scores of times.²

Herodotus, then, did not err: yet it is just possible that the name Termilæ, Tramelæ, was no more than the particular appellation of a Lycian tribe which, by extension, was applied to the whole Lycian people by imperfectly informed neighbours. Examples of appellations used in a double and triple sense might be cited *ad infinitum*, e.g. as applied to nations of any importance in the world's history; such would be the Jews, Greeks, Germans, and many more. In this particular instance, we have every reason to believe that the more general and oldest appellation was certainly that which persisted down to the last days of antiquity, the one by which the inhabitants of this province designated themselves on the coins bearing the legend: *κοινων Λυκίων*, "Lycian confederation." Homer furnishes a further proof of this. He stands about midway between Ramses III. and Herodotus, and he knows as little of the Tremilæ as the Egyptian scribes; whilst the Lycians play a conspicuous part in all the battles of the *Iliad*, in which they bear themselves bravely and far outnumber the other allies of Troy.³ Then, too, the description the poet gives of the country whence Sarpedon and Glaucus led out their forces in aid of the Trojans in their straits, coincides with Lycia. "It is very far removed from the Troad;"⁴ "brawling Xanthus flows in its midst;"⁵ and if this were not enough, he adds: "The Solymi are the constant enemies of the Lycians."⁶ No uncertainty exists as to the exact position of the country held by the Solymi; it was the tract ruled by Mount Solyma, and the latter, according to geographers, is represented at the present day by Taktalu-Dagh.

¹ Stephanus Byzantinus, s.v. Τρεμίλη; Menecrates of Xanthus; MÜLLER, *Fragm. Hist. Græc.*, tom. ii. p. 343, *Fragm.* 2.

² The name "Tramela" may be read in the great inscription of the obelisk discovered at Xanthus, and in the Lycian texts found at Antiphellus, Myra, Limyra, etc.

³ This is implied in the oft-repeated phrase, "Trojans and Lycians," used by the bard to designate the assembled forces opposed to the Greeks (*Iliad*, iv. 197; vi. 78, etc.).

⁴ . . . μάλα τηλόθεν ἦκω, says Sarpadon. Τηλοῦ γὰρ Λυκίη (*Iliad*, v. 478, 479).

⁵ Ξάνθου ὑπὸ δινήεντος (*Ibid.*, ii. 877).

⁶ *Ibid.*, vi. 184, 185, 204.

Why did the poet seek a people so far removed from the scene of action as were the Lycians, when he could so easily have found others better fitted, one would think, to fill their place—the Paphlagonians, Phrygians, and Mæonians, for instance, whose situation was comparatively near the Troad? Inspection of the materials out of which the *Iliad* was composed, now irretrievably lost, would doubtless give us the clue to the secret cause which prompted Homer in his selection. But even as it is, we think we can understand that if he acted in that way, it was because he was vaguely reminiscent of the relationship that once had existed between the ancestors of Hector and those of Sarpedon. Are not Tros and Tlos, one the name of the Trojans, the other that of a Lycian city, doublets, twin forms of the same word made slightly different by pronunciation? Troad has a river called Xanthus, but so has Lycia. Again, is there not some degree of probability that not only did the Lycians inhabit a canton of Mysia, the valley of Æsepus, but that they had spread along the coast, where later rose the Ionian centres? This, we think, may be inferred both from certain lines in Homer, as well as numerous traditions found in later writers.¹ In this supposition, the northern Louka would be a rear-guard of the bands which had at one time overrun Asia Minor and Lycia; when, along with the Iliouna, they sallied forth and broke through the Egyptian frontiers. Swept away from their homes by the wave of the barbarous invasions which, in the seventh century B.C., laid waste the peninsula, they were, in time, fused with the adjacent populations amongst which they had found shelter; whilst those of their brethren who settled south of Taurus prospered, and

¹ Pandarus is represented in the *Iliad*, both as a native of Lycia (v. 105, 173), and the chief of the Trojans “who dwell at the foot of Ida and drink the black water of Æsepus (ii. 824, 825). The historian of Alexander, Callisthenus, basing his narrative upon the testimony of the elegiac poet Callinus, wrote that Sardes was twice captured; first by the Cimmerians, then by the joint efforts of the Treræ and the Lycians (Strabo, VIII. iv. 8). The former seem to have been a Thracian clan which met the Lycians in their southward progress, when they marched together against rich Lydia. Of course, the southern Lycians were outside their line of march. When the Ionians, driven from continental Greece, settled in Asia Minor, not a few of their bands, says Herodotus (i. 147), chose their leaders from among the descendants of Lycian Glaucus. On the other hand, Pausanias numbers Lycians among the component parts of the primitive population of Erythræ, prior to the arrival of the Ionians there (VIII. iii. 7). In regard to the question under notice, consult TREUBER, *Geschichte*, pp. 14-18, 50, 51.

were left alone behind the insuperable bulwarks of their mountains, so that they could retain their name, the originality of their language, and their customs.

If we thus look upon the southern Lycians as the last representatives of a tribal group whose chequered existence was shared by the forefathers of the Trojans, we shall more easily understand how they came to occupy the situation, which the legendary lore collected by Homer assigns to them. It enables us, at the same time, to dismiss, as baseless, the explicit statements of Herodotus, to the effect that the Lycians had originally come from Crete, and that their name was due to the Athenian Lycon, son of Pandion.¹ In all likelihood, when Herodotus wrote his narrative, the last assertion had been recently coined, trumped up at Athens, whose policy it was to establish an historical link between Attica and Lycia, so as to induce the latter to enter the maritime federation set on foot by the Cimons and Pericles, with the object of compelling the cities on the coast to pay tribute.

Only for the sake of the thing shall we record the attempts that have been made to put a meaning upon the word "Lycian." The derivations that have been proposed are all taken from the Greek language. The Greeks of Rhodes and of Caria, it has been urged, as they steered towards the Asiatic coast, leaving the great island in their rear, saw the sun emerge from behind Cragos; in their ignorance they imagined that the god of light had his dwelling somewhere among those dazzling heights they had never scaled; hence they came to call the people who inhabited them *Leukoi*,² the "Luminous" ones, *i.e.* Orientals. The conjecture is ingenious; the fact, however, that if the Lycians are one with the Louka of the Theban inscriptions, they were so named long before the existence of Greeks in Caria or Rhodes, makes it unnecessary to argue the point.

Nor are these the sole tokens by which we may recognize in the Lycians, a people that had constituted themselves into a compact political body, centuries before the migratory movement of the Greeks in the eastern basin of the Mediterranean took place. The Lycian language is known from numerous texts,

¹ Herodotus, i. 173.

² From the root *luc*, signifying light both in Greek and Latin (G. CURTIUS, *Grundzüge der Griechischen Etymologie*, 5th ed., 1879, p. 160). Upon the various derivations of *Leukoi*, see TREUBER, *Geschichte*, pp. 28, 29.

some of which are of considerable extent; that of the Xanthus obelisk having no less than two hundred and fifty lines. The words of these texts are separated by dots, so that it is easy to make out the different parts of speech, which bilingual inscriptions, Lycian and Greek, help further to elucidate, and if the vocabulary is all but undeciphered, some notion of the nominal and verbal inflections has been gained. These enable us to guess at an exceedingly peculiar idiom, which most philologists class in the Aryan family of speech. But what place should be assigned to it in the family unit, and to which of its groups it should be allied, is a question regarding which prudent critics do not care to commit themselves.¹ As will be remembered, no such difficulty exists for Phrygia, whose language closely resembles Greek.

The marked originality of the Lycian idiom is in itself a strong presumption of remote antiquity. If the Lycians are indeed allied to the Indo-European stock, they must have separated from their congeners long before the Italiote, Greek, and Thracian tribes left their primeval home, in that their respective tongues offer among themselves striking analogies on the one hand, whilst on the other they have distinct correspondences with Sanscrit and ancient Persian.

Study of the Lycian alphabet leads to the same conclusion (Fig. 246). Like that of Phrygia and Caria, it was derived from the Phœnician syllabary, through the channel of a Greek alphabet which has been recognized as that current in the islands, and which was also in vogue in a district near Rhodes. To judge from the lettering in the vast majority of cases, as found in such inscriptions, as would seem to date somewhere in the interval of two hundred years separating the Persian from the Macedonian conquest, the aspect of the characters is even less archaic than that of Phrygian letters; their tracing is more regular, and the

¹ LASSEN, "Ueber die Lykischen Inschriften und die alten sprachen Kleinasiens," in *Zeitung der deutschen morgenlaendischen Gesellschaft*, tom. x. pp. 325-388; MORITZ SCHMIDT, *The Lycian Inscriptions after the Accurate Copies of the late Augustus Schönborn*, 1868; *Neue Lykische Studien*, 1869; SAVELSBERG, *Beitraege zur Entzifferung der Lykischen Sprachdenkmaeler*, Bonn, 1878; *Beitraege zur Erklärung der Lykischen Sprache*, Bonn, 1878. Carl Pauli, in his dissertation, *Eine vorgriechische Inschrift in Lemnos* (Leipzig, 1886), touches upon the question of Lycian characters (p. 590 and following). He inclines to connect Lycians and Etruscans with the Pelasgians, whom he considers as neither Semites nor Aryans, and consequently distinct from the Thracians.

à	A R
ā	X
ē	↑
è	E
ī	I
ì	⊕
v	B b
ō	B B
ū f	+
v	⋈ ≡ ⋈
ō	⋈ ⋈
u	∇ ∇ ∇ ∇
u	∇ ∇ ∇ ∇
ō	○
g	∇
c ²	< >
d	△
z	I
k	K
l	∧
m	∩ ∩ ∩
n	∩ ∩ ∩
p	∩ ∩ ∩
r	P
s	∩ ∩ ∩
t	T
b	F
»	⋈

FIG. 246.—Lycian alphabet.

downward strokes have a nearer approach to the vertical;¹ but whilst the characters which appear in the monuments of Midas (city?) are wholly borrowed from the Greeks, those of Lycia, in the mode of writing, betray traces of an older stage, of a period when her people employed the system of signs which the primitive inhabitants of the peninsula had derived from Hittite hieroglyphs. Thus, out of the twenty-eight letters of which the Lycian alphabet is composed, four are common to the Cypriote syllabary,² whilst two or three cannot be traced either to Phœnicia or Cyprus, and may likewise have originated from the older source. There is, then, reason to believe that when the Lycians adopted the Greek alphabet, not finding in it all the signs that were required to express certain sounds in their language, they retained a few of those they had hitherto employed, which they transferred to one or other of those Asianic alphabets, whose complicated arrangement caused them to be discarded everywhere, except in the island of Cyprus.

We feel the same impression when we try to collate the scanty data that historians have handed down to us relating to the institutions of Lycia. "This people," says Herodotus, "have a peculiar custom not met with among

¹ F. LENORMANT, "Alphabet," p. 209, in *Dict. des antiquités de Saglio*.

² SAYCE, "Inscriptions found at Hissarlik," p. 910, in SCHLIEMANN, *Ilios, City and Country of the Trojans*. London: Bell and Co.

any other nation ; the Lycians, in order to define their name, add thereto their mother's, and not their father's. If you inquire of any of them to what family he belongs, he will give you the name of his mother and the ascendants on his mother's side. If a freeborn woman cohabits with a slave, her children have the right of citizenship ; but if a freeborn man, no matter how exalted his rank, has children by an alien or a concubine, they remain outside of the city,"¹ *e.g.* they can have no civic rights. A much later writer, Nicholas of Damascus, but who had access to documentary sources now lost, corroborates the formal assertion of Herodotus, adding that family substance descended in the male and not the female line.²

It must be admitted that inscriptions show but very faint traces of the superior condition women are supposed to have enjoyed in Lycia ;³ the texts in question, however, are comparatively recent ; whilst we may assume that the action of Hellenic culture in its onward progress could not but efface local habits, rendered all the more easy that it did not clash with written laws, for the simple reason that the Lycians, we are assured, knew of no other except custom and usage.⁴

We have no reasons for discrediting the data bearing upon the earliest relations between the two people. If the habit under consideration had not been current among the Lycians, it is not in the least likely that the Greeks would have conceived the notion of attributing it to them. On the other hand, we can well realize their surprise when brought face to face with such a reversion of parts ; one too diametrically opposed to their customs, and therefore all the more calculated to attract their attention. The system which was still in force in the time of Herodotus, is what modern lawyers call *matriarchate*, of which vestiges have been traced among people and nationalities the most diverse, and which is generally considered a survival of a very primitive state of society, leading back to a period when the family had not yet constituted itself by marriage, when the relations of the sexes

¹ Herodotus, i. 173.

² *Fragmenta Hist. Græc.*, tom. iii. p. 461.

³ In regard to this subject read Treuber's observations, *Geschichte*, pp. 121-124.

⁴ Heraclides Pontinus, Fr. 15 (MÜLLER, *Fragm. Hist. Græc.*, tom. ii. p. 217). This same writer also alludes to the Lycian "gynecocracy," as he styles the ruling station of women in Lycia.

were solely guided by the whim of the moment or chance meetings.¹

Whatever path we take, then, we shall reach the same result; the Lycians of the classic age were the remnant of a people that figured in that primitive Asia Minor which, from the Amanus to the Ægean, was under the ascendancy of the Hittites, of their arms and culture. It is possible that many of their tribes were swept away, amidst the stir of populations and the bloody strifes consequent upon it; but some, we cannot say when, found shelter in the narrow strip of land that goes by their name, amidst the depths of lofty mountains where they could be easily isolated, and where they peacefully dwelt for centuries; whilst it is not unlikely that in the present occupiers of the soil we have their descendants. Most travellers who have visited the country think they recognize the sons of the ancient owners of the soil in the inhabitants of the upper valleys of Lycia, and that they are Turks only in name.² They base their opinion upon the nobility of types of the population, their dress, and the persistency of certain usages which bear the stamp of remote antiquity. They were converted to Islamism towards the end of the Middle Ages, so as to retain possession of their homesteads, precisely as many Greeks have done, whether in Pontus, Crete, Bosnia, or Albania. But none the less, the blood that flows in their veins, according to these same authorities, is not different from that which pulsated in those of the companions of Glaucus and Sarpedon. Invaders, as a rule, show no great predilection to establish themselves among the hills; for, besides being already occupied, they have very few attractions to newcomers, who would not feel safe among them, and would, moreover, find life exceedingly hard. Hence it is that the populations of mountain regions neither change nor are renewed with the same facility as on the tableland and the plains.

When the first Lycian tribes crossed Taurus, following the beds of the torrents that descend from its heights on their way southward, it was on the banks of the Xanthus that they settled. For

¹ CURTIUS, *Hist. Græc.*, tom. i. p. 96, n. 1.

² This is the view of Dr. von Luschan, Benndorf's companion during a journey to Lycia, a succinct exposition of which will be found in a paper under the heading, "Anthropologische Studien," in *Reisen*, tom. ii. chap. iii. In it are found curious details respecting the very peculiar manners of the Taktadshi group, "plank-makers;" a people whose sole avocation, as their name implies, consists in the preparation of timber.

Homer, Lycia and the valley of the Xanthus are one and the same thing. When he speaks of "broad Lycia,"¹ it is the valley of the Xanthus which is mirrored in his mind's eye, the only one to which the epithet could be rightly applied (Fig. 247). But this privileged canton had not been wrested without strife from the Solymi and the Milyes,² who were in possession. It was a long

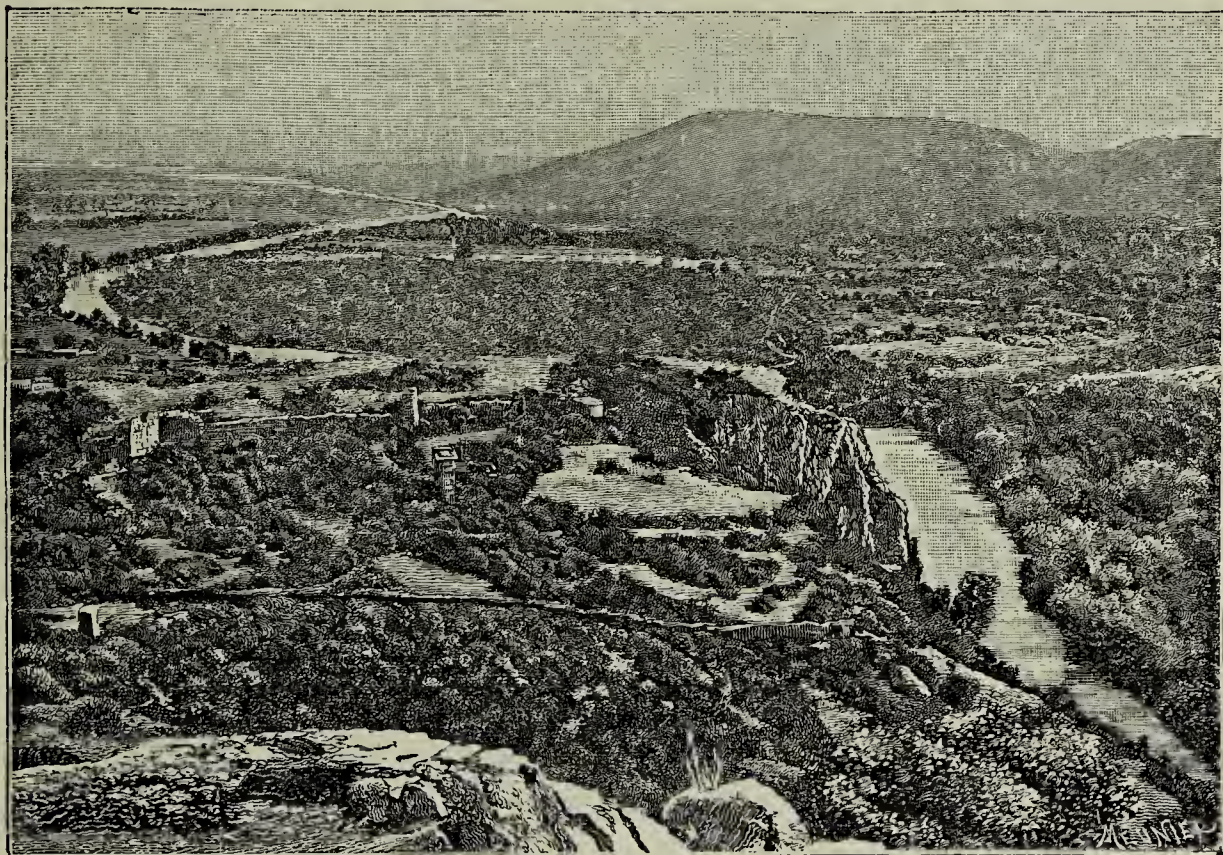

FIG. 247.—The Xanthus Valley. DURUY, *Hist. des Grecs.*, tom. iii. p. 253.³

guerilla warfare, during which the Lycians gradually but steadily gained ground, and in the end drove the natives on to the coast

¹ Λυκίη εὐρείη (*Iliad*, vi. 173, 188, 210, etc.).

² Strabo (XII. viii. 5; XIV. iii. 10) is aware that the primitive inhabitants of the district under consideration went by the name of Milyans and Solymi, and that the term Lycian was of later date; but he seems to think that the various names were applied in succession to one and the same people, an hypothesis not very probable in itself, and distinctly opposed besides to the formal testimony of the *Iliad* (vi. 184, 204), where the Lycians are described in conflict with the Solymi from generation to generation. Then, too, he contradicts himself, and confutes his own statement, when he speaks of the language current in Cibyratides, not as "that of the Lycians," but that which was spoken by the Solymi.

³ The above view is borrowed from Plate XIII. vol. i. of the *Reisen*. It is taken from a height north of Xanthus, facing south. Above the river rises the rocky eminence upon which stood the citadel; to the west of the rugged mass are still a few buildings of the city, half hidden amidst bushes. The sea is seen in the distance.

turned towards Pamphylia, and the elevated plateau in touch with Pisidia. Were the Milyes and Solymi of Semitic blood, as has been supposed? There are no data to prove or disprove the hypothesis.¹ The only thing we do know for certain is that no Lycian inscriptions have been encountered east of Massikytos.

Homer makes no mention of Lycian cities whose picturesque remains, set in a grand frame of mountains, are the admiration of every traveller. This, however, may have been due to the fact that when he wrote the city, with all the term implies, had no existence in Lycia, and that it started into being by contact with the Greeks of Rhodes, of Phaselis, and of the Carian coast. That the Lycians were stimulated by what they beheld in these intelligent centres, is proved by their adoption of an alphabet the chief elements of which are borrowed from one of the systems of Greek writing. Under Hellenic influence and the increase of wealth, the heights upon which the early immigrants had set up their hamlets gradually became veritable cities, with due accompaniment of citadels, public buildings, and necropoles. This change was accomplished somewhere about the sixth century B.C., when Harpagus, a lieutenant of Cyrus, marched against Lycia after having subdued the Ionians and Carians. Xanthus sent a force to check his advance; but it was routed in a battle fought outside the city, when the disordered troops retreated behind the walls of their citadel, set fire to the place, killed their wives, children, and slaves, and met their own death as they madly rushed into the ranks of the enemy.² Lycia had kept aloof from the Lydian empire,³ but had she felt herself menaced by her ambitious and turbulent neighbour; and many of her other towns (there is no reason to suppose that Xanthus stood alone) must have followed the example of the latter, and have surrounded themselves with ramparts behind which they could defend their territory. If we but hear of Xanthus, it is because her tragic end was so

¹ The testimony of Chœrilos (cited by JOSEPHUS, *Against Apion*, i. 22) has been adduced in regard to this subject, to the effect that he numbers among the soldiers who followed Xerxes in his expedition against the Greeks, "a Phœnician-speaking nation who occupy the Solymian mountains;" but Josephus identifies them with the Jews, and he would seem to be correct, since the poet, the better to define the situation of this people, adds, "close by a vast lake." No such thing exists in Lycia; if, on the contrary, we turn to Palestine we shall find the great Asphaltic Sea.

² Herodotus, i. 176.

³ *Ibid.*, 28.

memorable an episode in that campaign as to have been bruited afar. Frightened into submission by so great a catastrophe, the other towns opened their gates to the Persian conqueror, and engaged to pay tribute. This is the reason why the historian does not name them in his succinct narrative; but whilst Xanthus was the chief centre of the lower valley of the same name, Pinara and Tlos were undisputed mistresses of the middle valley. The

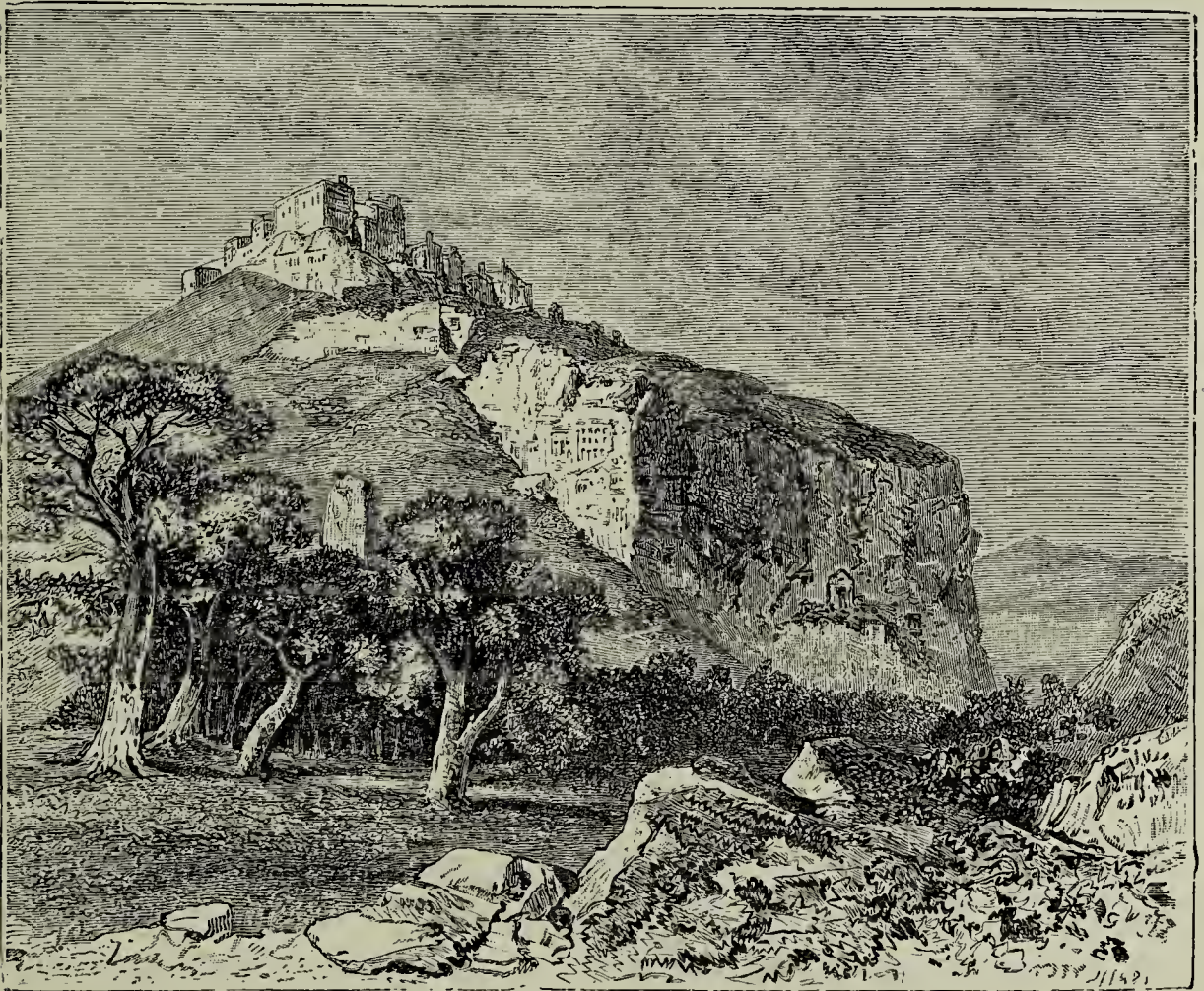

FIG. 248.—View of Tlos. FELLOWS, *Lycia, Caria*, Plate VI.¹

former rose at the head of a gorge on the right bank of an affluent which descends from Anticragos; whilst on the left bank Tlos, from its lofty and impregnable Acropolis, planted on one of the last counterforts of Massikyτος, watched over the plain which it ruled (Fig. 248). Then came Pidnaia and Patara, seated likewise

¹ The view is borrowed from Plate XXIII. tom. i. in *Reisen*, and is taken from an eminence to the north of the river. Above it is seen the rock that supported the Acropolis; whilst to the left of the rugged precipitous mass are still descried a few structures, representing the western portion of the city, amidst a tangle of bushes, with the sea in the distance.

opposite one to the other, like two sentinels, guarding a bay, with good anchorage at the entrance of the Xanthus valley, the latter being flanked on either side by mountain chains.

Patara, to judge from the extent of its ruins, was far the more important of the twin cities. Here Apollo had an oracle which was already famous in the day of Herodotus.¹ The gulf, like all the harbours through which passed the traffic of the valley, is turned into a marshy delta, and made impassable by brakes of reed-cane and tamarisks, so that the student finds it difficult to explore this and similar sites.

The Xanthus basin, with its numerous walled towns turned towards the sea and crowded in a narrow space, not only proves that it was the seat of a dense population, but the very heart of Lycia. Pre-eminent among them all was Xanthus, the "metropolis of the Lycian nation,"² as she proudly styles herself in the inscriptions of the Roman period. Nor was this a vain boast, since the sacred building of "Letoon," in which the delegates of the confederation were wont to assemble, lies at no less than four kilometres to the south-east of the town.³ Again, ancient geographers, notably epigraphic texts, tell of the situation of cities in Lycia in and about the sixth century B.C. Such was Telmessus (Macri), the principal port of the Cragos region, which better than any other could communicate with the island of Rhodes. She already possessed, in the reign of Cræsus, a school of soothsayers, famed throughout the peninsula.⁴ Much narrower than the

¹ Herodotus, i. 182.

² BENNDORF, *Reisen*, tom. i. No. 92.

³ With regard to the ruins that are visible about the place, read *Ibid.*, chap. xi.

⁴ Herodotus, i. 78. It has been argued that Telmessus did not become a Lycian city until the fourth century of the old era (TREUBER, *Geschichte*, p. 103). From the fact that it figures separately in the list of the tributaries of Athens (*C. I. Attic*, pp. 19, 22, No. 37, and pp. 104, 118, No. 234), as well as the statement of Theopompus to the effect that it had fallen to the hand of the Lycian king Pericles (Theopompus, Fr. 111 in MÜLLER, *Fragm. Hist. Græc.*, tom. i.). But it would seem probable that the Telemessus (*sic*) of the Athenian list, referred to an inland town of Caria, north of Halicarnassus, and consequently had nothing to do with Lycian Telmessus (SIX, *Monnaies lyciennes*, p. 93). As to the passage in Theopompus just mentioned, all we can say is that Telmessus, being separated from the Xanthus valley by the lofty chain of Cragos, carried on its existence for ages independently of the rest of the nation. Nothing indicates that it was either a Greek colony or a Carian centre. All the monuments found there bear an unmistakable Lycian physiognomy. The simplest thing is to consider it as having been peopled in very early days by Lycians. The same remarks apply to Kadyanda, a

Xanthus valley, that of Dembre-Tshaï, or Myros, was not as thickly populated. It has many windings; and is squeezed in between rocky walls which, in places, are perpendicularly cut; with the melting of the snow the waters devastate the land, and leave little that will repay cultivation. Nevertheless, the site of not a few small towns has been traced, whose inhabitants lived on the produce of meadow land and the fine forests stretching away on the neighbouring hills; these were Arniai, Kandyba, and Phellus, the latter being already mentioned by Hecataeus.¹ Nor should Myra, the most important centre of this district, be left out; its site is fixed with no less certainty, whilst the ground covered by its necropolis, as well as the shape of the tombs, impart thereto a very primitive aspect. At the entrance of this same valley, between the thick mass and the sea, rose Antiphellus, and Aperlæ, and Sura, ever ready to enter upon commercial or piratical emprise as occasion served. Finally, bearing to the eastward, Limyra looked down upon the fertile plain watered by the torrents which fall from the Elmalu plateau and the eastern slopes of Mount Solyma. In this brief enumeration we have omitted more than one town whose name is recorded either by ancient writers or inscriptions, and have confined ourselves to such as contain literary documents, along with monuments whose features are sufficiently distinct to permit us to see in them the representatives of cities travelling back to the days of Lycian independence. Their list will doubtless grow longer, inasmuch as travellers report many other sites where the ruins betray this same stamp of antiquity. For the present the difficulty is to identify them with one or other of the many names of Lycian cities preserved by ancient geographers, notably Stephanus Byzantinus.

The internal affairs of Lycia are very imperfectly known, down to the opening years of our era. From that day forward, Greek and Latin documents are plentiful, and furnish us with many a curious detail in regard to the social and political condition of the province. In the preceding epoch Greek inscriptions are

little way to the north. The Indus valley, wild and unpopulated, formed a sharply defined frontier between Lydia and Caria.

¹ Stephanus Byzantinus, *s.v.* Φελλος. If Hecataeus placed Phellus in Pamphylia, it was because, in his time, the boundaries of the different provinces of the peninsula were as yet undefined. For Hecataeus as for Homer, Lycia, strictly speaking, was the basin of the Xanthus.

short and rare, and, besides, few are older than the successors of Alexander. As already observed, Lycian inscriptions still await decipherment, with the exception of half a dozen formulas or so, that add nothing to our knowledge. As to historians, they take little heed of this small people, who, hidden behind a belt of mountains, like a tortoise in its calipash, had no part in the quarrels of the great powers of the world.

That which in a large measure enables us to supplement the insufficiency of literary data, is the study of the configuration of the soil, along with the ruins that are sprinkled on its surface. The Persian empire was not one where the central government was strong enough, its policy systematic enough, to make it possible to frame laws that should be binding on every subject, irrespective of race and language; laws, in fact, whose constant and lasting action would attenuate differences bearing on local customs, and sometimes succeed in effacing them altogether. The Lycians were subject to the Achæmenidæ in name rather than in fact; Darius comprised them in the satrapy of Iaouna, the chief of his divisions, and they were supposed to contribute four hundred talents¹ as their share of the tribute levied upon the province; yet in 300 B.C. Isocrates wrote, "No Persian king was ever lord of Lycia."²

Mountains in Lycia entirely cover the soil with their ramifications, and subdivide it in so many distinct sections as to have made it impossible for any one captain or city to unite the territory into one state. The pre-eminence of Xanthus was purely honorary. Lycia, that Eastern Switzerland, was carved out by nature for cantonal existence, and was bound sooner or later to drift into a federal system. People of one family and language, inhabiting valleys which mountains keep apart, ere long feel the need of breaking through their isolated position, of meeting at festivals common to both, and frequenting market-places open to all. Lycian federacy, as described by Strabo,³ would appear to have constituted itself late enough after Alexander the Great; conscious that union of all the clans is the surest means of being respected abroad; but its organization had certainly been prepared by more than one essayal, more than one compact concluded at the end of perhaps years of warfare between adjoining townships, those

¹ Herodotus, iii. 90.

² ISOCRATES, *Panegyric*, 161.

³ Strabo, XIV. iii. 3.

of the Xanthus valley for instance. We can read by the light of many signs that temporary groups, partial leagues had been formed, before the great association (*temp.* Augusto), in which figured twenty-three towns, each with a number of votes proportional to its size. Thus, both in official documents—such as the list of tributes paid to Athens by the allies—and histories, the natives of this province are often designated as “the Lycians,” an expression which seems to imply that they were considered as one body of people.¹

Again, all the Lycian coins struck under the so-called rule of Persia belong to a uniform monetary system; whilst the same symbol appears on the reverse of the vast majority, leading to the inference that they were destined to circulate throughout the territory of Lycia.²

And again, the monuments, architectural or sculptured, tell the same tale, presenting as they do uniformity of aspect from one end of Lycia to the other. This we should find hard to explain, unless we admit that, despite the splitting up of their territory into numerous fractions due to natural causes, the Lycian people, in very early days, possessed federal institutions, rude and imperfect no doubt, but which served none the less to keep alive the memory of primitive union among all their children. We know not how these cantons were constituted and what form of government they obeyed. It would seem that each had an hereditary nobility, out of whose ranks were selected princes who sometimes succeeded in bringing under their authority several neighbouring towns. One curious feature to be noticed is the importance the city acquired in Lycia, an importance that may be gauged from the passionate devotion of her citizens. In time of peace her inhabitants vie with one another to endow her with fine buildings, and raise monuments in her midst that shall perpetuate the memory of their exploits and munificence; when pressed sore, rather than surrender her to the foe, they elect to bury themselves under her ruins. Nor is this an imaginary picture. Twice in the course of her existence is Xanthus said to

¹ In regard to the subject under notice, see TREUBER, *Geschichte*, p. 112; Herodotus, i. 90, vii. 92; ISOCRATES, *Panegyric*, *Λύκιοι καὶ Ἰωνντελείς*; *C. I. Attica*, 161; Diodorus, XV. xc. 3.

² SIX, *Monnaies lyciennes*, 8vo, 109 pages and two plates (*Extrait de la Revue numismatique*, 1886, 1887).

have offered such an example to the world;¹ once at the time of the Persian invasion, and long after, when she was besieged by Brutus, Cæsar's murderer.² We find no parallel instance, either in the north or the centre of the peninsula. Hence the idea suggests itself that if a people made up of ploughmen and woodmen, rose to a notion of the city and devotion consequent upon it, long before the tribes of Cappadocia, Phrygia, and Paphlagonia, it is probable that they had learnt it by contact with the Greeks of Phaselis and Rhodes; the more so that they built their towns in imitation of Hellenic centres, and provided each canton with a capital whose Acropolis commanded the country around. Those who first copied Greek models could not but have found it a convenient scheme. Quarrels, in regard to a piece of woodland or pasturage lying close to the border, must often have occurred between these small communities. During similar affrays the immense advantage of placing man and beast in safety behind fortified walls must have been felt on all hands.

Lycia is washed on three sides by the sea, which advances in between the saliences of lofty promontories and forms bays, closed against the wind blowing from the main by a barrier of clustering islands; it lies peaceably at the foot of mountains that yield an abundance of timber of excellent quality. Consequently, as soon as the Lycians turned their eyes towards the sea, they could have as many ships as they needed, which they not infrequently ran, as privateers, against the Rhodians.³ There is no doubt that a certain amount of maritime traffic was always carried on in and out amongst these coasts, unbroken, like those of Caria and Ionia, into fjord-like bays which advance far inland and continue the great fluvial valleys, hollowed by nature for the very

¹ As the formal statement of the text is rebutted in the footnote, I thought it better to make the sense dubious, so as to prepare the reader for what is to follow.—TRS.

² APPIAN, *Civil Wars*, iv. 76–80; Dion. xlvii. 34. There seems to be no foundation in the story according to which the Xanthians once again met their death rather than surrender to Alexander, during his progress through Lycia (APPIAN, *loc. cit.*, iv. 80). Arrian, who is so exact, has naught about it, and represents Lycia as having submitted without striking a blow (*Anabasis*, i. 24). As to Diodorus, if he mentions so tragic an event, it is that he may credit the Pisidian town of Marmara with it (xvii. 28). The second catastrophe was an invention of the rhetors, in whose eyes the Xanthians were bound to go through the same tragedy every time an enemy knocked at their gates.

³ Heraclid. Pontinus (MÜLLER, *Fragm. Hist. Græc.*, tom. ii. p. 21).

purposes of trade, which it has always followed and will continue to follow to the end of time. Lycian valleys, not excepting those of the Xanthus basin, appear short and narrow, as against those of the Mæander, the Cayster, the Hermus, and the Sangarius. Their precipitous sides and gullies become so many brawling torrents in the rainy seasons, rendering them impassable during many months in the year; so that they can never serve as ways of communication between the seaboard and the central plateau of Asia Minor. The country is thus reduced to its own resources, but these are sufficiently great to provide the elements of a brisk trade. As we have seen, only a small portion of the soil is under cultivation; but even when every foot of ground was made productive, it can barely have yielded grain enough for home consumption. The rearing of cattle and the timber of the forests must at all times have been the sole industrial means of the country. Its exports at the present day are still sheep and oxen, which are shipped off to Rhodes; and wood, whether for combustible or building purposes, which finds its way to Smyrna, Beyrout, notably Alexandria. In such narrow conditions as these, it was yet possible for the native population to live a happy, though frugal and humble life. The fact of their having been squeezed in between their elevated narrow valleys cannot but have fostered a conservative turn of mind; hence it is that we find them retaining longer than any of their neighbours on the Asiatic coast, the use of an alphabet and a language peculiar to them, along with institutions such as the "matriarchate," which elsewhere disappeared much sooner. Then too, even when conversant with all the arts of Greece, they for centuries went on repeating in their necropoles forms suggested by the only style of architecture they had known at the outset—that which, in building the house, used none but squared and unsquared pieces of timber.

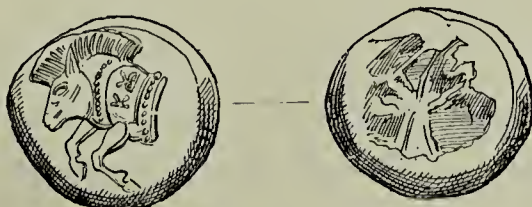

CHAPTER II.

ARCHITECTURE.

FUNERARY ARCHITECTURE.

THE Lycians, to consider them only during the period of their independence, have left but few monuments outside of their tombs ; but they are of so marked a character as to have struck travellers such as Leake, Fellows, T  xier, Spratt, and many more, who, in the beginning of this century, revealed them to Europe along with the country in which they occur. In the number of these tombs (of which plans and drawings were made), very few travel back to the period within which we wish to confine ourselves in this history of art. The vast majority of the exemplars we shall cite are later than the Persian conquest, and not a few, accompanied by Greek inscriptions, date from the Macedonian era. Nevertheless, we shall find that the original aspect of these monuments was not suggested by Grecian art, since the forms that are proper to the latter, have naught comparable to the bulk of those that appear in the Lycian necropoles.

To account for the fact that types so peculiar as these should have persisted ages after their creation, we must suppose that they were truly indigenous, with all the term implies ; and had originated from practices, imposed by the nature of the materials employed, intimately bound up with the life of the Lycian people, who persistently clung to them even when their statuary had made itself thoroughly Greek in style, and borrowed most of its themes from Hellenic myths, to decorate these very tombs. Consequently, whatever be the date, real or supposed, these strange monuments carry about them, and which Lycia alone possesses, we are

entitled to figure them here as survivals and witnesses of a remote past, as true representatives of national architecture.¹ Sepulchral mounds are unknown in Lycia, and are proper to flat countries. If we have met the type on the borders of the Smyrnian bay, in the Hermus valley, and the coasts of Caria, it is just possible that we ought to look upon it as the survival of an old habit contracted in far-off days, when Mysian and Phrygian tribes still occupied the plains of Thracia; a type they had brought with them when they invaded Asia Minor, and which long practice caused them to retain for a while at least. The neighbouring tribes of Lydia and Caria borrowed it from them. The populations that inhabited the western part of the peninsula were all closely related; the languages they spoke resembled each other, and some of their cults were common to all; hence amalgamation between many of these clans had been easy, and so complete that they could not be distinguished one from the other. Not so with the Lycian people. Wherever they came from we find them entrenched behind Taurus apart from the rest. Their territory was a network of narrow valleys, and the rock was everywhere to hand, but of sufficient softness to lend itself to be attacked without much effort, and of sufficient firmness to retain almost entire shapes traced by the chisel. Hence it is that from the outset, tombs were excavated in the depth of the stone. Rectangular niches are recognized on all hands as the most ancient type; these are generally met with in the neighbourhood of towns, their dark apertures looming out of the face of tall walls perpendicularly cut.² They are cut to a depth of about two metres, and quite plain; the rock in places is perfectly honeycombed with them, so that a little way off—below the Acropolis at Pinara, for example—the stone surface looks as if covered with gigantic wasps' nests. Such niches are open, and seem always to have been open; nor is there much probability that thieves, even the most reckless and daring, would have cared to risk breaking their necks in order to rifle them. They are almost all inaccessible, so that to excavate even the lowermost scaffolding had to be set up close to the calcareous rock, and

¹ Our account of Lycian tombs is no more than a summary of Benndorf's exposition in *Reisen*, pp. 95-113, tom. i. chap. ix. By far the greater proportion of the woodcuts found in the book are reduced copies of Niemann's skilful and accurate pencil drawings. Others are taken from the photograph plates of von Luschan, which serve to illustrate Benndorf's work.

² BENNDORF, *Reisen*, tom. i. pp. 48 and 96, Plates XVIII. and XL.

a whole apparatus of pulleys fixed to the apex of the cliff for the upper specimens. Similar recesses may have received human ashes, but there is no reason why corpses enclosed within coffins should not have been safe in them, since nothing short of a pair of wings would enable one to get so high up. Then, too, it is probable that these niches are not all of one date, or very ancient; since we know that they continued to be pierced in the flank of the hill for the accommodation of the poor, even when funerary architecture, bent upon gratifying the conceit

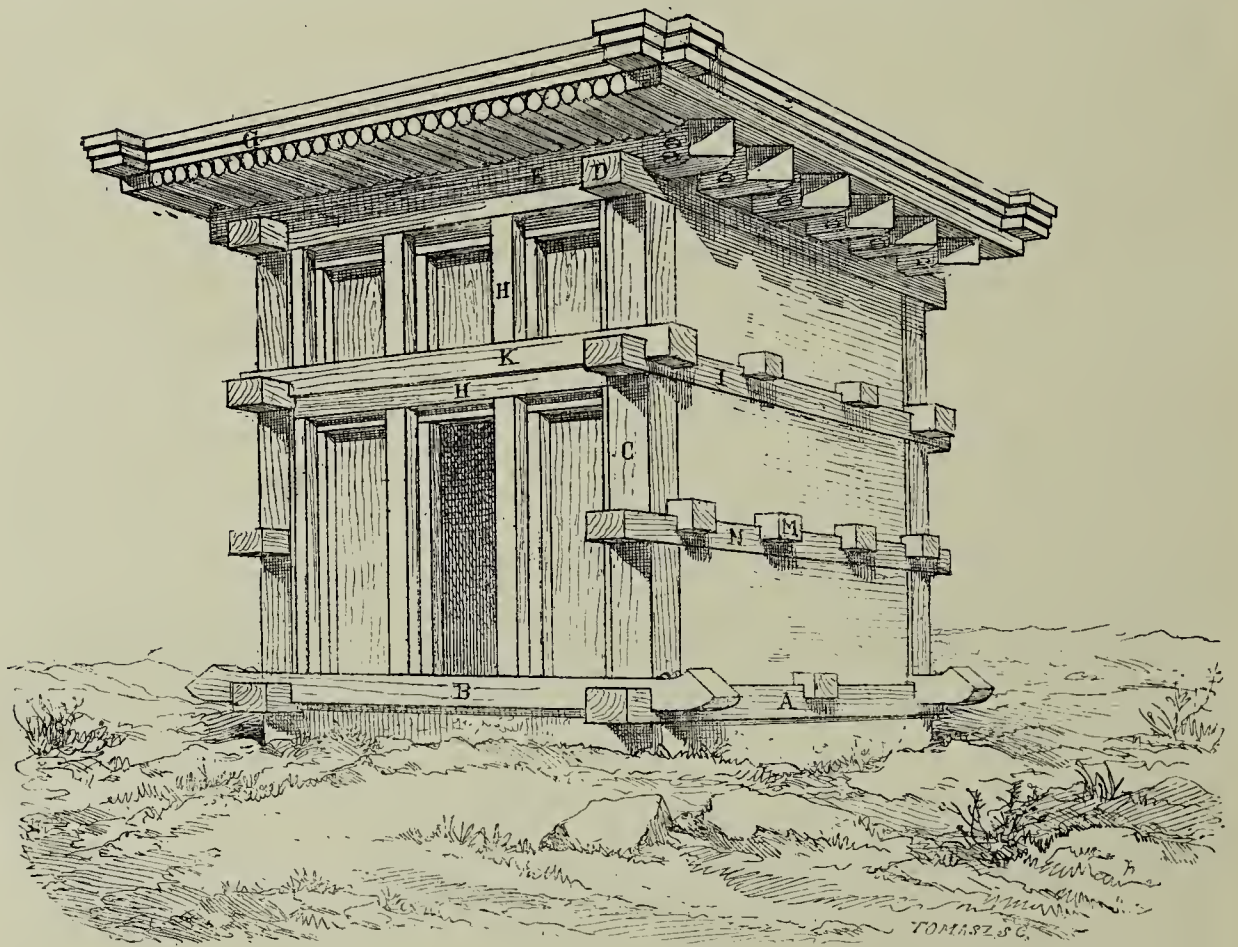

FIG. 249.—Wooden house in Lycia. Restoration of primitive type. BENNDORF, *Reisen*, tom. i. Fig. 53.

of the wealthy, had learned to fashion more complicated stone shapes.

The most original tomb of Lycia is also the most ancient, and the reproduction on stone of a wooden construction. It admits of many variations, but they are all reducible to one type, the characteristics of which are clearly brought out in the annexed diagram (Fig. 249), due to M. Niemann, the architect who accompanied M. Benndorf to Lycia. Upon a plinth which represents the ground, or rather the low wall which was to prevent the planks from

coming in contact with the damp earth, rest the lower cross-beams, A, B. It will be observed that the mode of connecting these and the various timbers that make up the frame is by scarfing, well seen in the side-posts, c. At the angle where the pieces meet, we sometimes find the broad head of a pin, driven in to secure the work. D is a double girder, which not only prevents the uprights from spreading, but supports the principal rafters that form the under portion of the roof, and ties them in at their feet as well. Then comes the real cover-

ing, which is horizontal, and consists first of small beams closely put together,¹ the extremities projecting well beyond the façade, upon which were laid beds of earth beaten down. Above it is the cornice, composed of three beams set lightly in advance one of the others, and made to cross at the

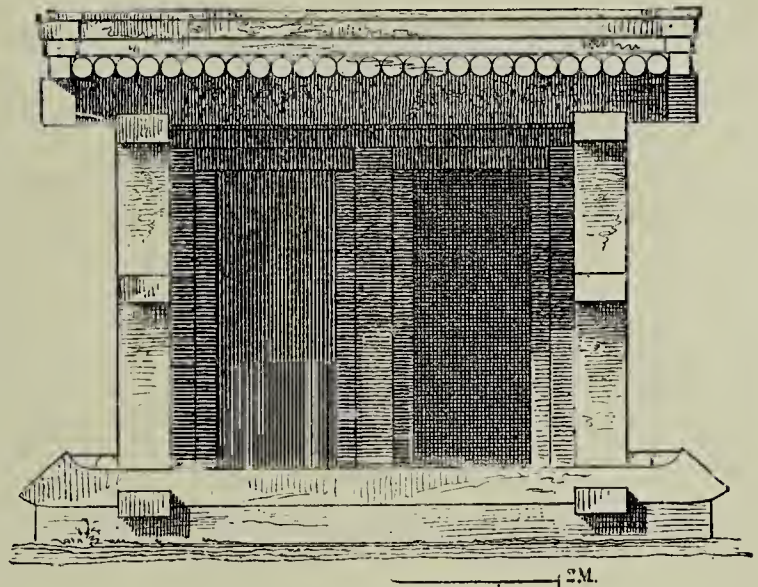

FIG. 250.—Tomb at Keuibashi. BENNDORF, *Reisen*, tom. i. Fig. 80.

four corners. It thus constitutes in plan a salient and stout capping, well calculated to keep in place the clay underneath. Our illustration (Fig. 250), which represents one of these sepulchral façades, will enable the reader to grasp the disposition of this class of roofs.

The spaces between the main beams of the principal façades are filled in with a wood framing of square pieces, which divide the surface into recessed panels, like those of a ceiling, the number of which is regulated by the size and height of the fabric. The back and side walls are quite plain and closed with flat boards, which the sculptor often utilized by covering the rock-cut tomb with bas-reliefs (Fig. 251). The wall-plates or horizontal beams, N, I, K, that divide the surface into compartments, correspond with the stories of the wooden hut, and, together with the uprights, support the joists of the floor, or ceilings, M. A side view

¹ In a tomb at Pinara the round beams of the roof are replaced by square joists, but this is the exception, not the rule (BENNDORF, *Reisen*).

of our model leaves the impression that the timber hut has two stories above the ground floor: in the tomb, however, in order to enhance the effect of the frontispiece and the importance of the funereal chamber, the horizontal beam of the first story has been left out, so that door and panels are two stories high. If the door in our illustration is not indicated, it is because vaults were sealed with a slab fitting a groove—a mode of closing improper to

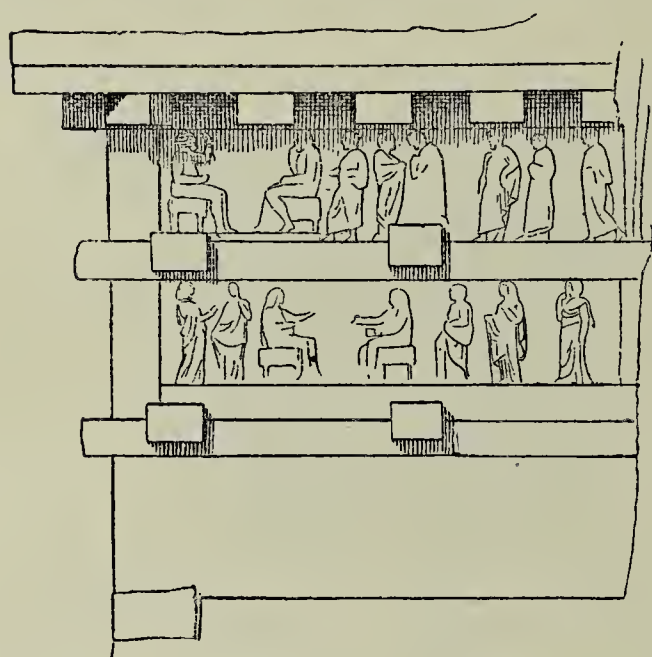

FIG. 251.—Tomb at Hoiran. Lateral eastern side. BENNDORF, *Reisen*, tom. ii. Fig. 16.

wooden constructions. The size of the pieces that make up the false timber-framing is proportionate to the scale of the tomb in which they occur. In a general way the uprights have a mean square of thirty centimetres, whilst the diameter of the small round beams is about ten centimetres.

Here and there, particularities of a purely decorative nature are observable in the type we have just reconstituted, which cannot

be explained by the exigencies of the materials, and must be ascribed to the individual taste or whim of a nation. Such would be the crocket-like ending of the cross-beams, B C (Fig. 249). In order to find aught resembling it, we must needs travel to the far East, to Japan, the doorways (*tūri*) of whose temples exhibit, placed lintel-wise upon wooden shafts, beams turned up at the extremities exactly like these.¹ Then, too, the light salience of the entablature is quite as remarkable; for its straight profiles, unbroken by curves of any kind, were not calculated to throw off rain water.

It would be vain to deny that more than one detail about the structure under consideration is exceedingly singular; yet its main lines are decidedly those of an ordinary timber structure, which any chance artisan could reproduce at will. When we see with what constancy the dispositions we have described reappear in every tomb, we are loth to believe that the type to which they

¹ BENNDORF, *Reisen*, tom. i. p. 95, Fig. 52.

gave rise was the work of a single day, invented for the sole purpose of entombment, and the conviction forces itself upon the mind that it is no more than a petrified wooden house, the copy of a style of domestic dwelling which at one time obtained throughout the country. On the ground floor were the stables; the household occupied the rooms of the first story, over which was the loft or store-room. For the rest, the building was of the simplest description—no oblique joining of the timbers, no gable roof; and as its component parts were apt to shrink and give way, it always failed in the one essential of solidity. Finally, as every man who has travelled in Syria has learnt to his cost, horizontal roofs are doubtless capital screens against the heat, but their very flatness unfits them for throwing off the rains that fall in great abundance for days together during the winter months. A system with serious drawbacks such as these would never have been retained unless coeval with Lycian civilization itself, long habit having made its creators insensible to its defects. A parallel case may be observed in Japan, where for thousands of years the natives have been faithful to a style of house, of which the timber framing is still more elementary than that which we surmise behind the veil of the rock-cut sepulchre.

Some have advanced the opinion that tombs of this kind are an exact representation of a funereal pyre.¹ The notion is so strange that we find some difficulty in understanding how it ever was allowed at all. Is it conceivable that the Lycians would have endowed their pyres with so complicated a shape, and have been at the trouble of squaring and connecting timbers about to be destroyed? The conjecture is all the more risky that the internal dispositions of these sepulchres presuppose that bodies rather than human ashes were deposited in them. The remains of stone houses, said to exist on the site of Lycian cities, are adduced in support of the above theory; but similar remains are seldom found except in districts where wood is scarce. Moreover, wherever irrefragable evidences have permitted to fix the date of such fragments—at Istlada, for instance—it is found that they do not lead back to high antiquity.² From the day when Lycians adopted Greek models, the chief citizens, those with Ionian sculptors in their employ, must have directed them not only to decorate their tombs, but to construct them stone

¹ SEMPER, *Der Stil*, i. pp. 230, 315, 318, 430, and following.

² BENNDORF, *Reisen*, tom. i. pp. 30, 99.

houses as well, so as to be distinguished from the rank and file. Around the stately edifice, however, the lower classes lived in houses that were but a development of the wooden hut—a conjecture which the study of the ruins combined, with the evidence of historians, to bear out in full. Of all the places within Lycia, not one perhaps has kept the vestiges of the past in better preservation than the elevated plateau of Cragos, where once rose the little town of Sidyma, whose every stone structure, no matter how small, is not only standing, but almost entire. The fact that no traces of houses are met with leads one to suppose that they were wholly built of wood;¹ and, if so, their destruction must have occurred at a comparatively recent period, since the town is not heard of as of any importance until the Roman dominion. There is nothing improbable as to a tiny centre lost upon the silent plateau having disappeared. Do not we find a parallel instance in Xanthus, the chief city of Lycia, twice consumed by fire; and if a few hours sufficed to bring this about, is it not because, as Constantinople and Broussa until within a few years, they were built of combustible materials? Houses in Lycia, it is needless to say, were not lighted with petroleum; had they been of stone, therefore, they could not have been so easily burnt down.

The vestibule of far the most important tomb in the necropolis at Pinara displays curious bas-reliefs representing, it is supposed, views of the Lycian cities that were subject to the prince who was buried there. They are bare outlines of the walls, gates, and main buildings of four cities, with tombs crowning the summit of mounds or ridges of some extent (Figs. 252, 253).² Two out of the views would seem to be copies of timber structures. Thus the second row of edifices situated in the upper city, seemingly consists of two blocks of masonry three stories high, entered by a portal raised on several steps. Rudely outlined as it is, the building recalls none the less those vast seraglios of Asia Minor, where in more than one town I have seen the governor of the province giving audience.

To return: the structures to the left exhibit a very marked salience

¹ BENNDORF, *Reisen*, tom. i. pp. 60, 99.

² *Ibid.*, pp. 52-54. The above views were published by Fellows; but his imperfect drawing led to conclusions wide of the mark. Thus, for instance, a sarcophagus seen from its short side (Fig. 252, lower panel) was mistaken for a building with cupola. Our woodcuts are from copies made for Benndorf at the British Museum, and consequently far more reliable.

between the second and third story. Was not this intended for the extremity of the cross-beam which projects beyond the angle of junction? Could a more graphic allusion be devised to the mode of connecting timbers together, to which we have repeatedly drawn attention? Be that as it may, no ambiguity exists as



FIG. 252.—Views of cities, Pinara. Benndorf, tom. i. Fig. 36.

to the nature of the construction which in the next bas-relief (Fig. 253) occupies the upper part of the lower picture on the right. Here the façade, over which appear the ends of the joists and wall-plates, is divided into panels, very similar to carpentry work. There is but one point which is doubtful: namely, whether the

building in question is a real house made up of beams and planks or one of those tombs hollowed in the rock, in the fashioning of which the stone-cutter tried his best to imitate wood methods.

Stone as well as timber buildings, according to localities, are

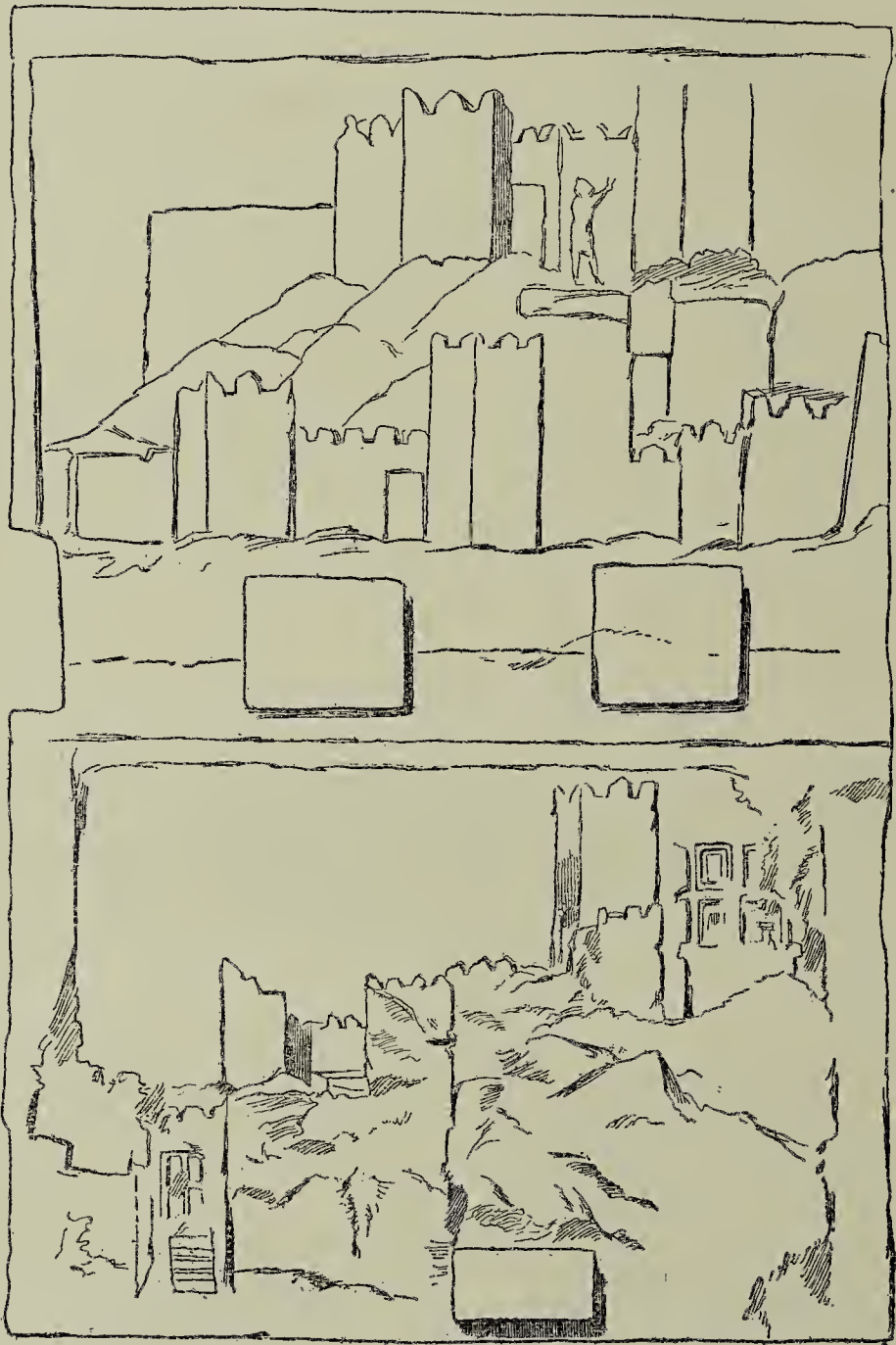

FIG. 253.—Views of cities, Pinara. Benndorf, tom. i. Fig. 37.

encountered in Lycia at the present day ; yet even where the walls of the house are of unsquared blocks of stone, united with moist clay, wood always plays an important part in the construction. The modern house is no longer a mere timber-framing, like that displayed or guessed at in the antique rock-cut tomb. The walls

are made of dry stones held together with a little mud ; the flat roof, however, is still covered with beds of clay, and upheld by posts engaged in the wall, but outwardly free, so as to provide



FIG. 254.—House at Ghendova. BENNDORF, *Reisen*, tom. i. Fig. 49.

a double gallery to the rustic house of two stories (Fig. 254). Where the dwelling has but one story, an open verandah or porch is built, sustained by a number of pillars, for the convenience of the inmates, where they can sit or move about as well. The more general type is seen in Fig. 255.¹

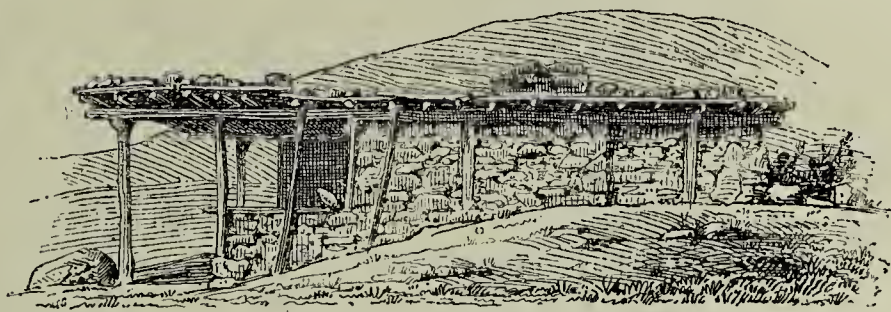

FIG. 255.—House at Ghieuben. BENNDORF, *Reisen*, tom. i. Fig. 26.

It is not the domestic abode, then, which has preserved the primitive type as revealed in the Lycian tomb ; but curiously enough it crops up in those stone rooms found in the vast majority of Lycian villages. They differ, however, in one particular from the model that forms the object of our study, in that the roof has been raised so as to slope

¹ BENNDORF, *Reisen*, tom. i. p. 100.

its sides for the throwing off of rain water, which would damage the stores put in them. Sometimes, as in Fig. 256, the king-post is tied in at its head by the principals, where they cross at the angles; sometimes the struts are visible in both gables (Fig. 257), so that, with the exception of the roof, the resemblance is startling between these granaries and the hut we have restored after the sepulchral façades. Here again, both girders or wall-plates and joists, all the pieces of the timber frame up to the first story (M, M), are united together by scarfing, and the ends left very salient.

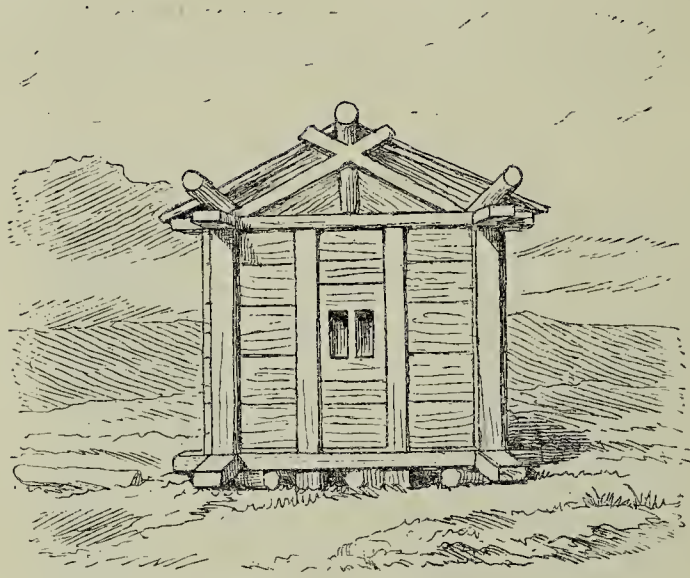

FIG. 256.—Lycian store-room. FELLOWS, *An Account*, etc., p. 129, Fig. 2.

The larger beams are found at the angles and serve as posts. Pierced above man's

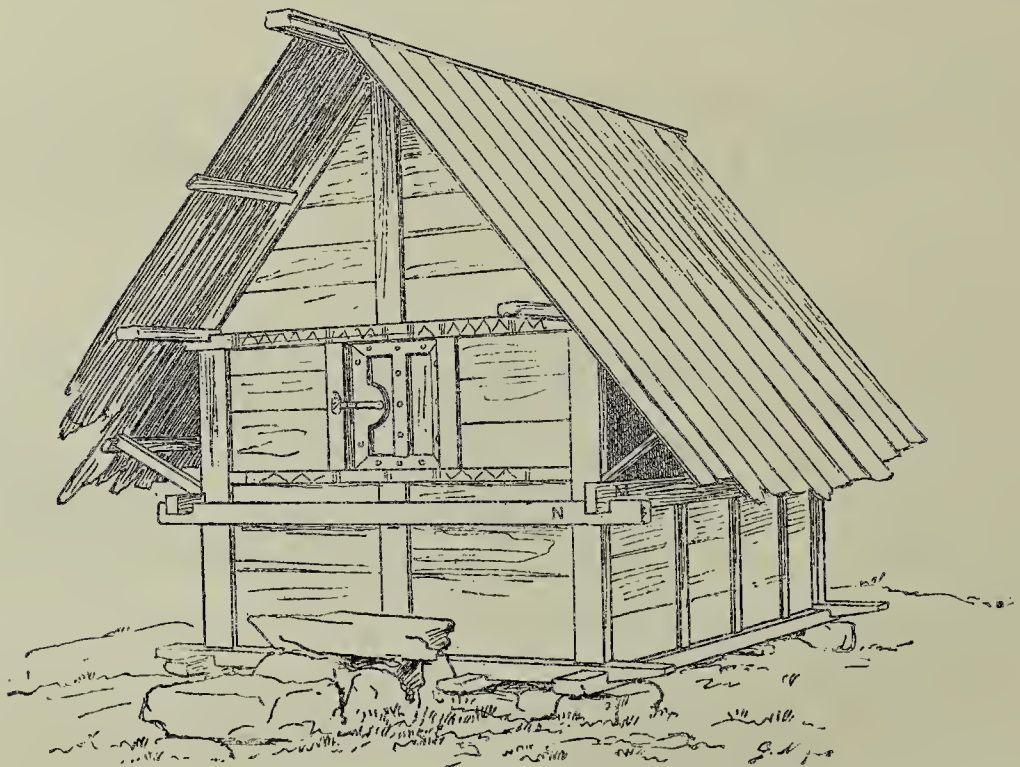

FIG. 257.—Lycian granary. BENNDORF, *Reisen*, tom. i. Fig. 56.

height in the middle of the façade, is a door barred and locked, but so low that to pass within anybody but an infant must crawl.

The fabric does not rest on the humid ground, which would soon damage its sides, but is raised on large stones.

Perhaps the most curious method for connecting timber is that which appears in Fig. 258, where the planks that form the walls of the structure are made to cross at the sides within a foot of their heads, and the result is a very quaint aspect. This mode of piecing wood together is not in the habits of the Turk or Greek joiner, whether of the towns or plains; and we find no trace of it in their carpentry work.¹ It is proper to Lycia, or, to speak correctly, to mountain regions where wood is plentiful; and is a contrivance which makes iron bolts and nails superfluous. We noticed it in the hilly tract of Olympus,



FIG. 258.—Hut at Kurje Keui. PETERSEN, *Reisen*, tom. i. Fig. 58.

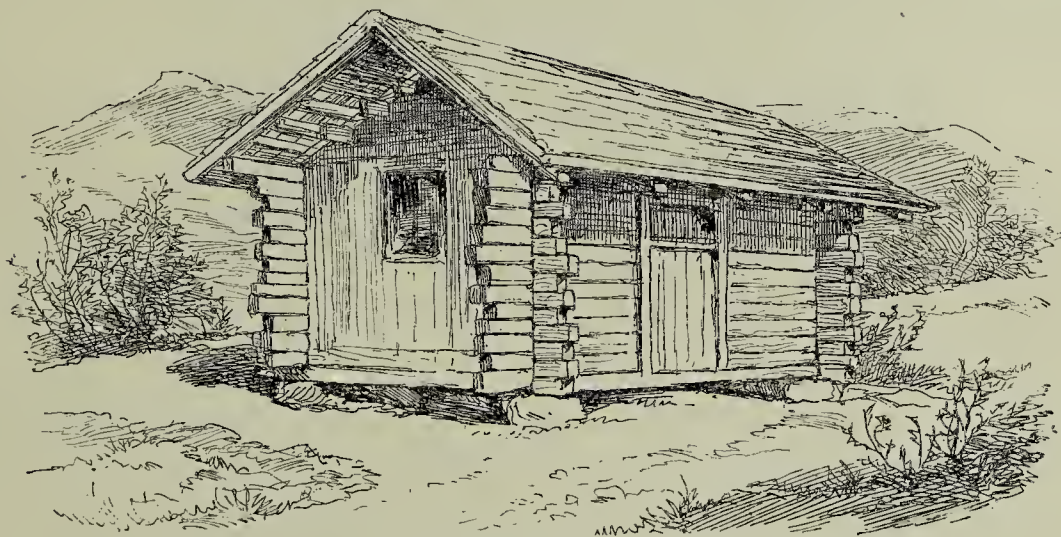

FIG. 259.—Granary at Villards de Thônes. Drawn by Marie Perrot.

in Bithynia.² It is still used in the construction of domestic dwellings and barns, whether in Lycia or the upper valleys of Savoy. Look at the sketch on p. 365, made by M. Niemann (Fig. 258), representing a guard-room which stands at the crossing

¹ BENNDORF, *Reisen*, tom. i. p. 100.

² *Hist. of Art*, tom. v. p. 73.

of a road somewhere in Lycia ; could anything be found more closely resembling the granaries that meet the eye of the tourist in Savoy, as he makes his way up the slopes of Aravis (Fig. 259)? Social conditions must undergo profound transformation, in order to effect definite change in rural districts, where the tendency is to remain what the surroundings and natural resources of the soil have made them at the outset. Take the Swiss village—not, of course, one kept up by visitors, like Interlaken, which is no more



FIG. 260.—Tomb at Hoiran. BENNDORF, *Reisen*, tom. i. Fig. 24.

than a number of hotels, but the real typical village, lost among the hills—and you will find that houses there are identical with those that obtained in the day of Ariovist.

If this be true as regards Europe, it must surely apply with greater force to Lycia, where villages have, in all likelihood, not much changed in aspect since the fabulous age of Glaucus and Sarpedon ; with this notable difference, that when all the country was flourishing and more densely populated, the houses of the peasantry were doubtless more spacious, and built with greater care. As a rule, rock-cut tombs reproduce but a front view of the house which served them as model. Sometimes imitation of

reality is carried further. This happens when a lateral wall is added to the façade, so that we obtain a side view of the primitive Lycian house as well. Fig. 260 shows the street corner of a necropolis hard by the village of Hoiran, whose ancient name is as yet unknown, in which the two modes of representation may be observed. Now and again the effort of the copyist has outstepped beyond this, and prompted him to disengage the long sides of the building, so as to leave only the back adhering to the cliff (Fig. 261). Though more seldom, he even went so far as to completely isolate the tomb, and set free its four sides (Fig. 262). The false construction is, then, a faithful image of the house, or store, which, created by domestic architecture in far-off days, was taken up by funerary architecture, and repeated without a break for centuries.



FIG. 261.—Tomb at Pinara. BENNDORF, *Reisen*, tom. i. Fig. 37.

It is easy to grasp the ideas and feelings that led the Lycians to endow their tombs, on the outside, with the aspect of the house. To them, as to other nations of antiquity, life beyond the grave was but the continuation of that which man had led in the light of day. It was natural, therefore, to put him in a building which should recall that in which he had spent the days he had been allotted on earth. A curious point to be noted here is that the interior of the tomb has no correspondence with its exterior.¹ To obtain out of the living rock the members of carpentry displayed on the outside, great expenditure of time and labour were required; and all we find behind the façades so curiously wrought is a chamber without trace of moulding, and so low that a man could not stand upright in it. The mortuary chamber often contains three couches; one pierced in the farthest wall, and the remaining two

¹ BENNDORF, *Reisen*, tom. i. p. 96.

on each side of the vault. It is but very seldom, too, that double rows of rock-cut niches, like those of the Phœnician vaults,

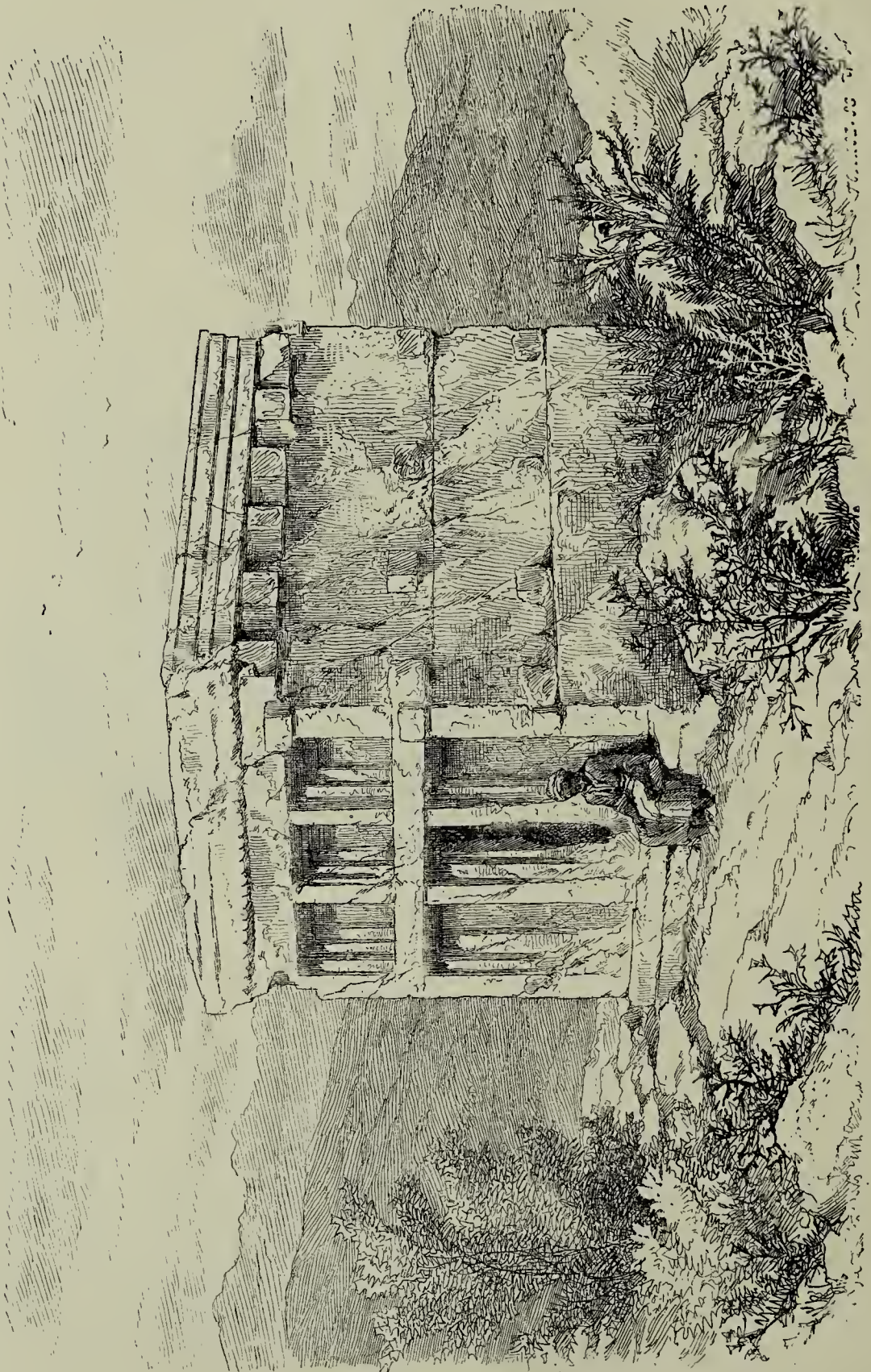

FIG. 262.—Tomb at Phellus. BENNDORF, *Reisen*, tom. i. Plate XXXVII.

occur here ; whilst vestibules preceding the chamber form the exception, not the rule. Such would be the Pinara exemplar

connected with a sepulchral chamber (Fig. 263), of which a perspective view is given in Fig. 261. It was an open vestibule, divided into two sections by a pilaster, wherein we recognize a copy of the beam which in the wooden house upheld the roof of the pent-house. The entrance to the hypogeum was closed with a slab, and stood behind this kind of porch; but it was neither on the axis of the vestibule nor of the chamber—an irregularity that may have been due to the shape of the rock in which the sepulchre was excavated. As to the doorway, if in defiance of the laws of symmetry it faces a side opening in the porch, it was to facilitate the passage of the bodies.

Nowhere in this region do we find rows of chambers, such as obtained in the centre of the peninsula; whilst no attempt at architectonic effect is perceptible in the specimens whose approaches testify to more ambitious aims. Hence it is that Lycian tombs, even the most ornate, always remind us of what they originally were—mere holes, just large enough to receive a corpse.

No transition is observable between the primitive tomb and that which simulates the front of a wooden house covered with a flat roof; so that we are led to conclude that, from the day when they adopted this mode of construction, imitation of carpentry work was everywhere faithful and complete. There is but one notable deviation from this universal rule. In addition to the terrace-roof sustained by small beams (roundels), we find a second covering, a roof with double slope, which, seen front-ways, yields a curvilinear gable, ogee-shaped (Fig. 264).¹ Some have supposed that this was in imitation of those light constructions set up, in warm countries, on the terraces terminating the houses, so as to screen the inmates against the sun or evening dew, and which become the living apartment during great part

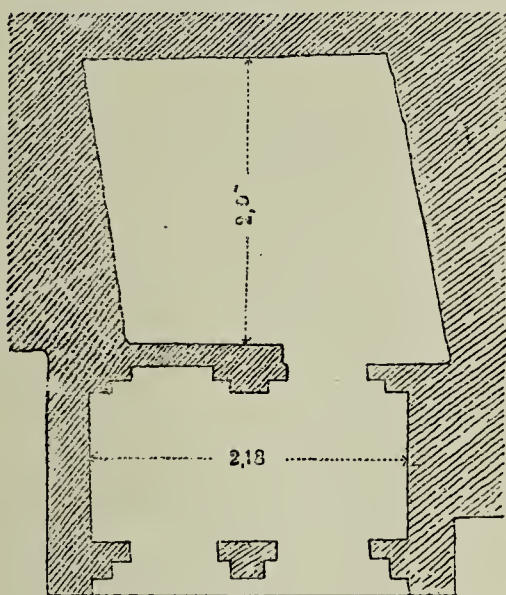

FIG. 263.—Plan of tomb. Pinara. BENNDORF, *Reisen*, tom. i. Fig. 34.

¹ Instances of an arched gable roof, though less frequent, are also met with. Such would be the covering of a tomb at Hoiran (BENNDORF, *Reisen*, tom. i. p. 33, Fig. 25).

of the day, and, in summer, during the nights as well. Such appliances, however, are no more than tents sustained by stakes;¹ but the ogee-shaped attic of the Lycian tomb, like the rest of the façade, is very similar to carpentry work made up of large pieces of wood (Fig. 264), such as joists, the heads of which project beyond the main rafters, with two false tie-beams and a strut

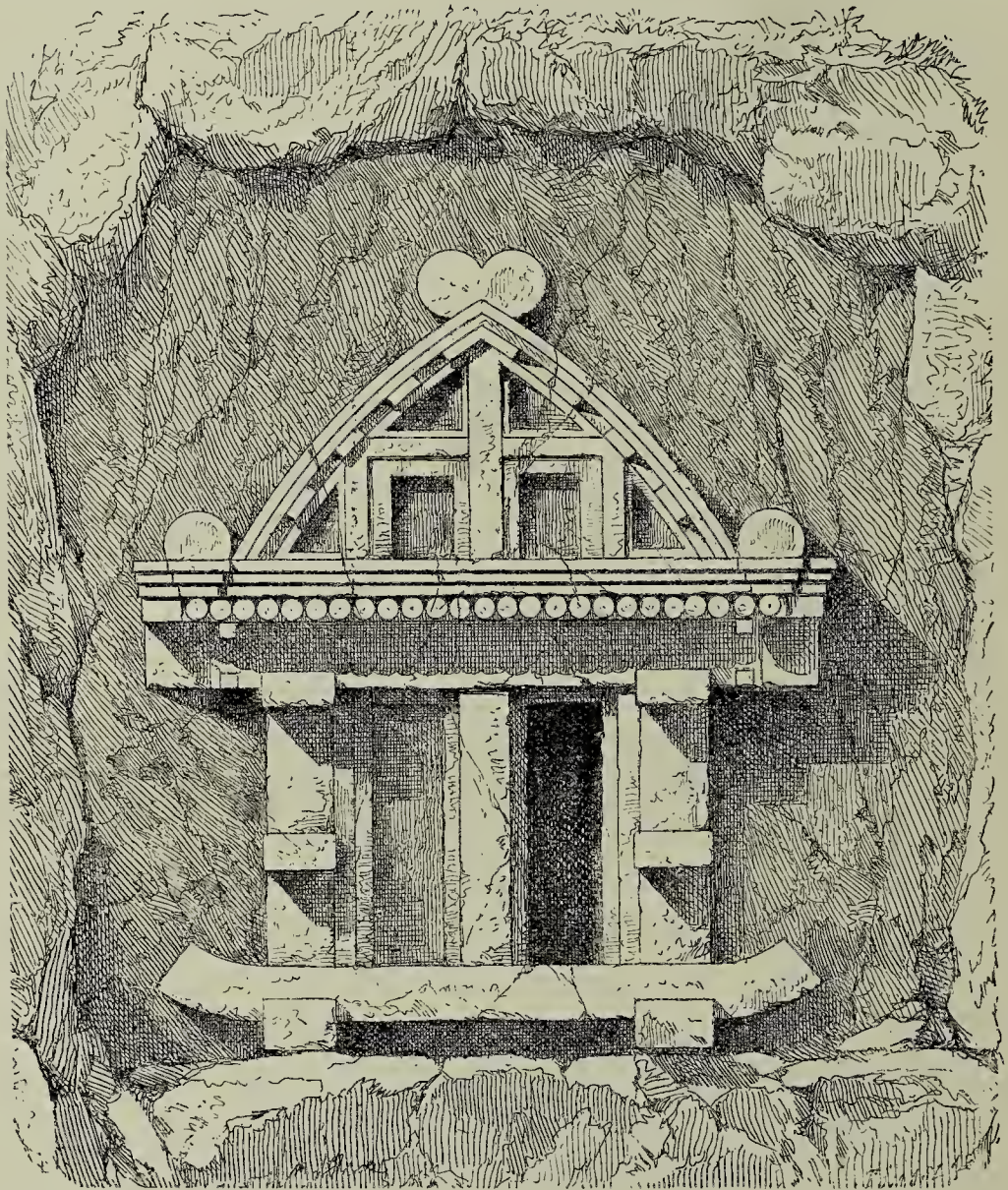

FIG. 264.—Tomb at Myra. TÉXIER, *Description*, tom. iii. Plate CCXXVII. Fig. 3.

properly so called, both being maintained in place by struts, exactly as in Phrygian tombs (Figs. 58, 59). Then, too, the angles and the apex of the gables are often ornamented by appendices which, both here and in Phrygia, play the part of what the Greeks

¹ BENNDORF, *loc. cit.*, p. 105. In the Biblical passages collated by Benndorf in proof of his theory, the word in the texts, to designate the construction under notice, is rendered by *σκηνή*, tent, by the Greek translators.

call acroteria. These, in Fig. 264, from a tomb at Myra, are represented by rude balls; whilst a façade at Pinara displays, in the same situation, the horns and ears of a bull (Fig. 265). Was this ornament designed to bring to mind the sacrifice offered to the dead at the time of his entombment, or does it testify to a custom dear to the Lycians, in common with many country people at the present hour, of setting over the doorways of their houses or enclosures the head of a bull, of a horse, or other animal? Be that as it may, it was practised in Greece, where it was allied to a religious idea;¹ and from it may have been derived the device known as "bucrane" or bucranium.

The feet of the side pieces of the curvilinear roof are comprised between the beams, which not only kept down the beds of clay, the real covering of the house, but prevented

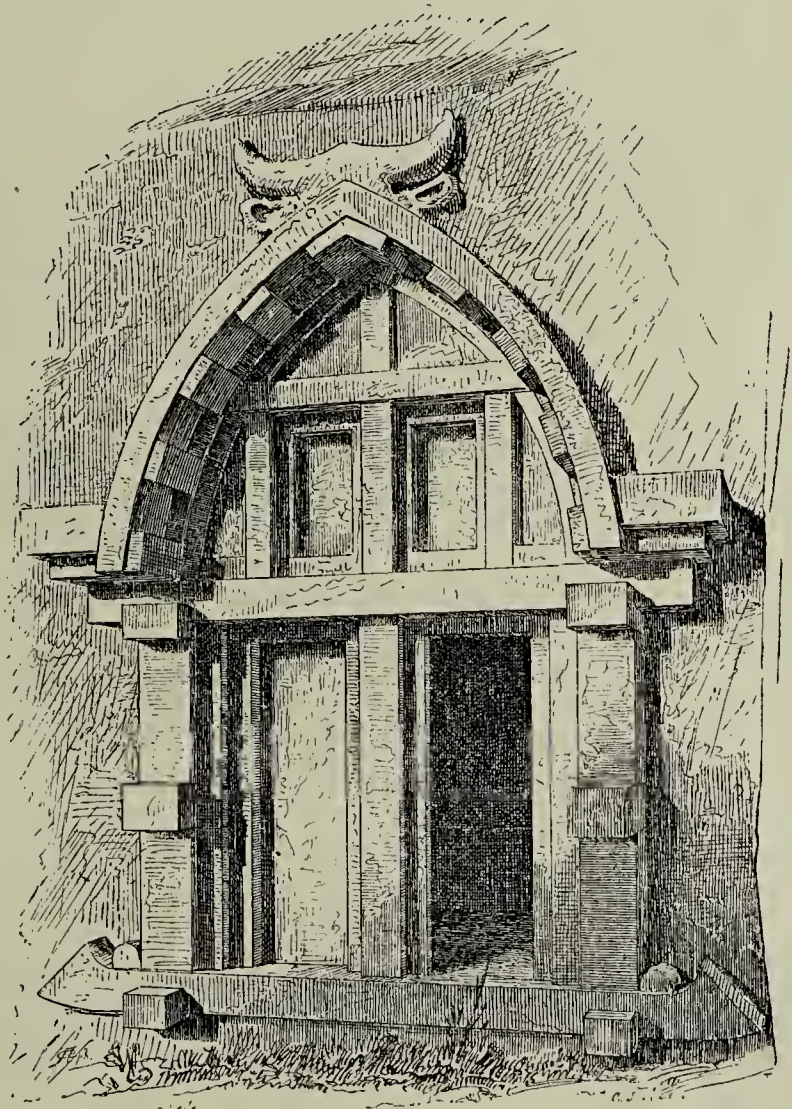

FIG. 265.—Tomb at Pinara. Benndorf, tom. i. Fig. 33.

the main rafters from spreading. Here, again, every detail lends itself to the conjecture that we are confronted by a faithful copy of a model once familiar to every eye; moreover, we have reasons for supposing that a certain number of these Lycian châlets had a pointed loft just large enough for a top room or store, in which wood, forage, etc., could be stowed away, very similar to the triangular attics of the Swiss châlets. This last class of loft

¹ With regard to the above question, read what Benndorf has to say about it in *Reisen*, tom. i. p. 52, n. 3.

likewise appears in the funereal façades of Lycia ; but, as a rule, the tombs in which it occurs (Fig. 266) look younger than those with gable roofs. In countries where winters are severe, the

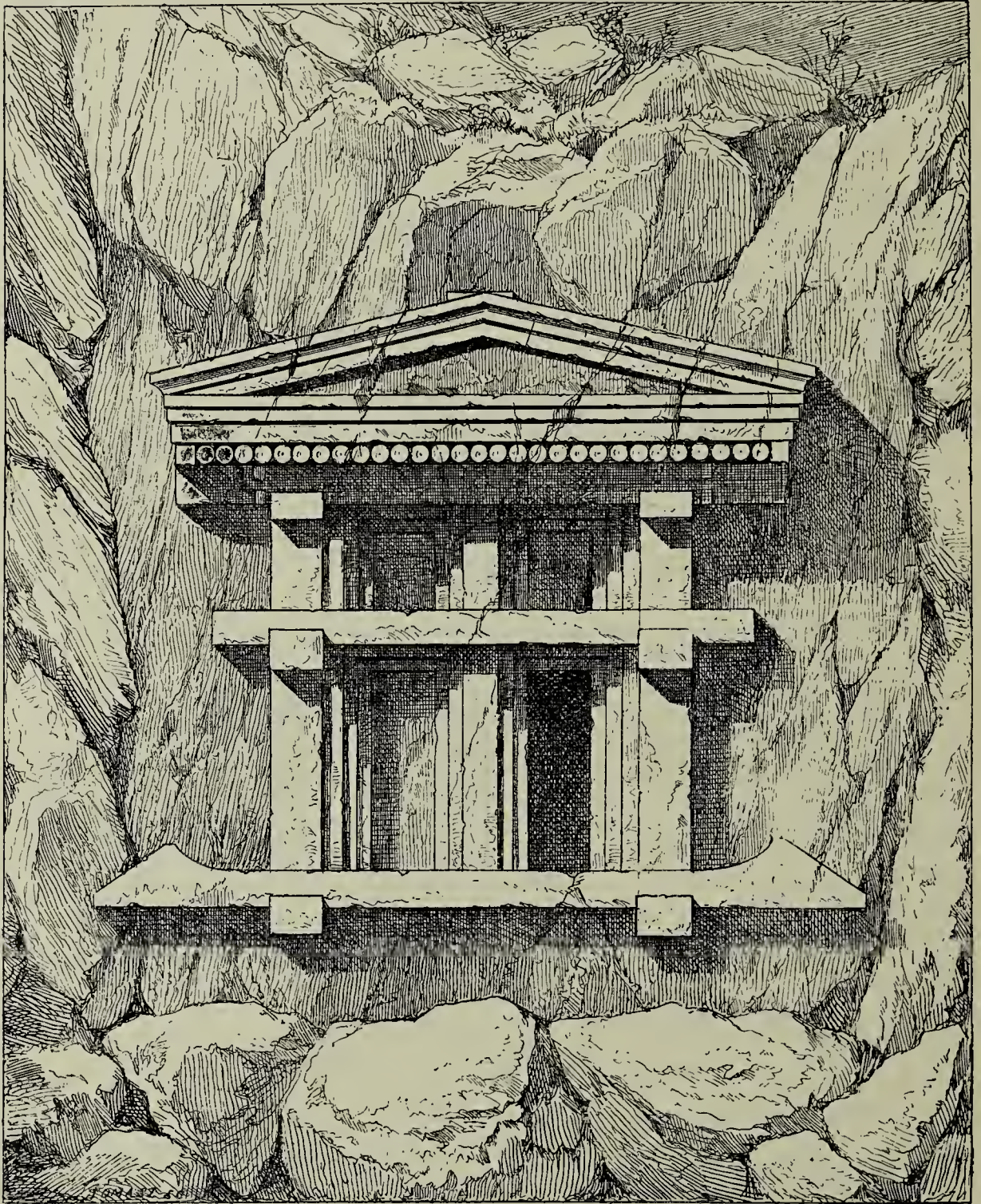

FIG. 266.—Tomb at Antiphellus. TÉXIER, *Description*, Plate CCI.

ogee-shaped attic was a better covering than a flat or even a triangular roof, in that the snow could more easily slip down its sides, and must therefore have been widely employed in those regions. What proves that the curvilinear roof obtained in certain

cantons is the fact that from it was derived the form of the Lycian sarcophagus (Fig. 267). Some two thousand of these sarcophagi, of which the short side reproduces the front of a house, have been encountered in Lycia, and in Lycia only. They consist of a very ponderous movable lid, furnished with saliences which served as handles, and a vat into which were put the bodies of the family one after another; whilst underneath is often found a kind of vault or *hyposorion*, in which the servitors found their last rest. These funerary monuments are sometimes built; sometimes both vat and base supporting it are cut in some rocky mass.

This is not the place to describe the varieties offered by sarcophagi of this kind. The example we have adduced suffices to show that the creations of Lycian architecture, one and all, even those in which one would least expect it, were influenced by and derived from timber constructions. So far we have given a summary of the architectural shapes distinctly peculiar to Lycia; it remains to note a monument which does not seem to come under that denomination, and which is known as the Tomb of the Harpies, from the figured bas-reliefs that decorated it, now in the British Museum. The removal of the sculptured slabs that formed the sides of the chambers is the cause of its present disfigured and mutilated aspect. It is a type made up of a square mass, tower-shaped, in which the mortuary chamber is perched under a flat and very salient roof, which expands into a daïs-like shape. To give the reader a good idea of this kind of tower, we will reproduce a specimen from the Xanthus Acropolis, which has not been ravaged (Fig. 268).

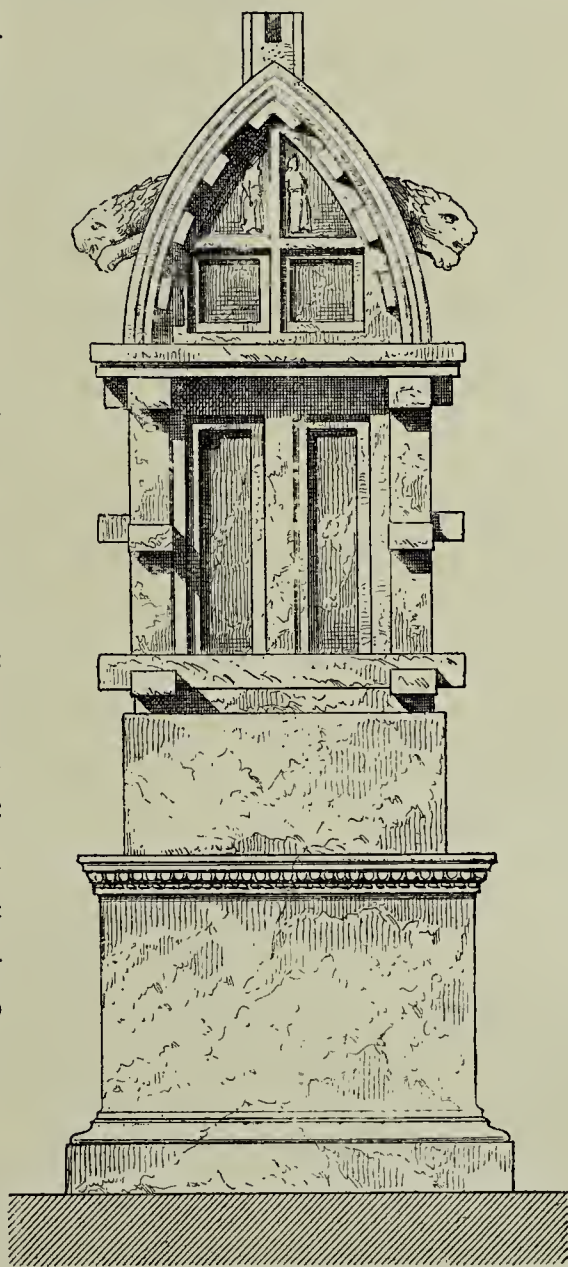

FIG. 267.—Sarcophagus at Antiphellus.
TÉXIER, *Description*, Plate CCXXVII.

The rocky mass was cut in such a way as to leave a "stepped" plinth and rectangular tower, with a recess or vault above, formed of four slabs of marble,¹ and a couple of tombs of the usual type below. The doors to the chamber in this and other sepulchres at Xanthus were all small, whilst a vault at Ghieul Bashi is but eighty-five centimetres by nine; making it self-evident that similar tombs could only be used by practising incineration.

The height of these sepulchral monuments averages from three to six metres; their number is small, and does not amount to more than about fifteen throughout the extent of Lycia;² they would seem to be the oldest tombs as yet discovered in this region. Such would be Figs. 273-275. Considered as a whole, the group leaves the impression of a type that never became popular, but was restricted to a few great families, and abandoned in very early days. The more recent tower-sepulchres would date from the fourth century B.C. In our estimation, the explanation offered as to the origin and character of the monuments under notice, has completely failed of its purpose. They have been compared to the funerary towers of Persia, and the question has been asked whether we are not faced here by tombs built for Persian satraps; but one of these exemplars at least, that at Ghieul Bashi, does not lend itself to the above hypothesis, in that it may very likely be older than the conquest of Lycia by Harpagus, and that the hold of the Achæmenidæ over the province was purely nominal. Again, the Tomb of the Harpies, which, with its bas-relief, is far the most carefully wrought of the series, does not reveal a single point that could in any way remind us of Persian creeds. Admitting for the moment that a vague resemblance is perceptible between the Lycian towers and those of Meshed-i-Mūrghāb and Naksh-i-Rustem, the differences are distinct enough to nullify the hypothesis of direct imitation, and relegate the likeness, real or supposed, to the domain of coincidence. It is just possible that the notion of the tower-shaped tombs was suggested by those watch-towers of frequent occurrence in regions whose territory is divided between hostile clans, and that the guard-room perched on the top of the slender edifice became the mortuary chamber. Timber towers may have obtained at an early age, but the combustible materials of which they were

¹ BENNDORF, *Reisen*, tom. i. p. 87.

² A list of the sepulchres in question will be found in *Ibid.*, pp. 107, 108.

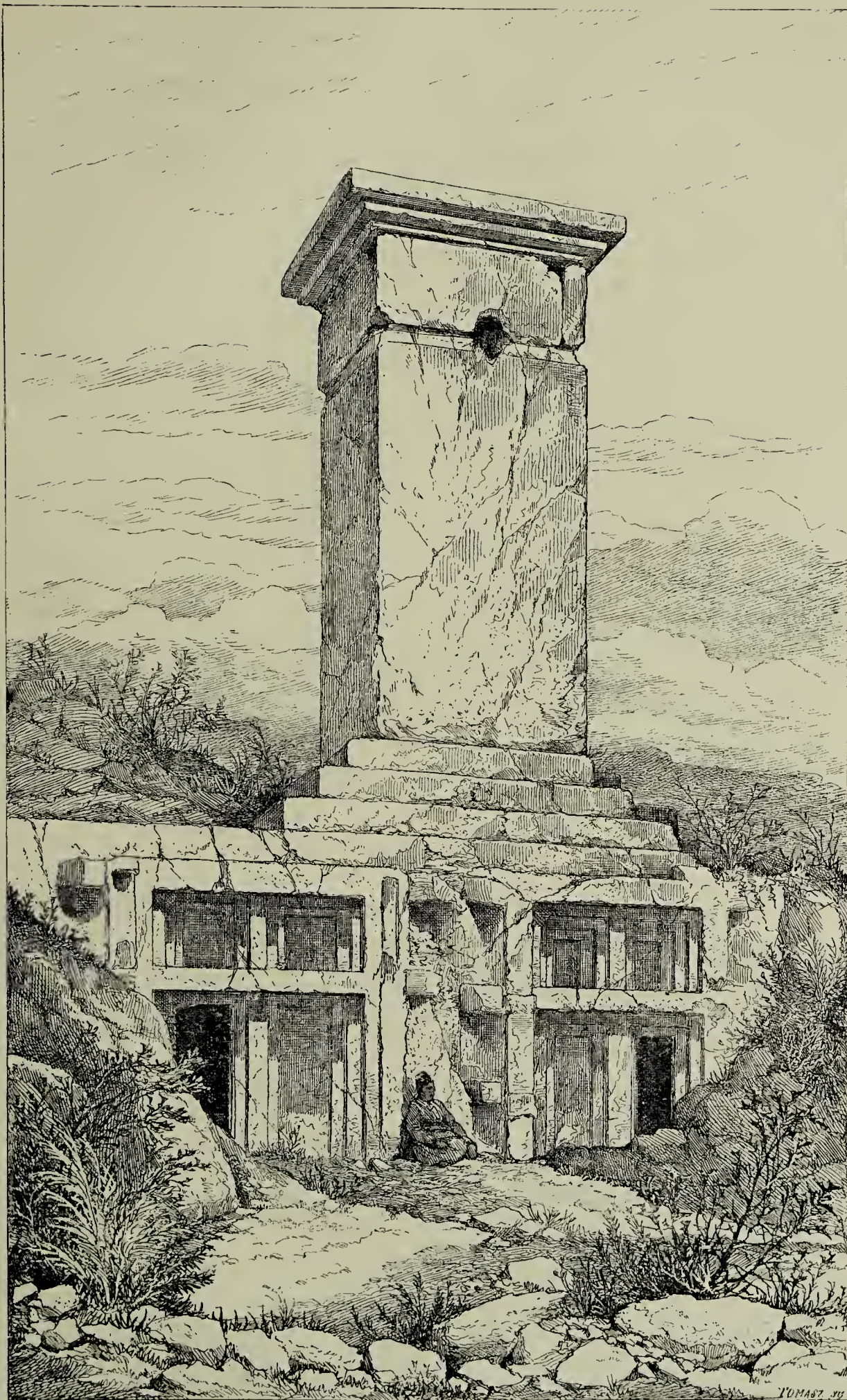

FIG. 268.—Funerary tomb at Xanthus. BENNDORF, *Reisen*, tom. i. Plate XXV.

made exposed them to be easily burnt down; so that the advantage of using stone in their construction must ere long have been recognized. The idea of having a lofty and stout burial-place may first have occurred to a local magnate, who would thus continue to look down upon the familiar streets and squares of his native city, in which he had played a conspicuous part.

We will not pursue farther the history of funereal architecture, inasmuch as it forms no part of our scope to study monuments which, whilst preserving features borrowed from primitive and local types, are thoroughly permeated with the spirit of Greece. To sum up, the tomb is by a long way the most characteristic monument of Lycia. Nowhere else do we find so large a number of sepulchres executed with greater care; and, in especial, nowhere else do we find such minute precautions taken, as are here revealed, to place the mortal remains under the tutelary wing of the gods, and—the better to secure them against profanation—under that of the future generations inhabiting the city. Care is taken to interest them in the repose of the human ashes, by settling upon them the pecuniary fines to which desecrators rendered themselves liable. Laws enacted against the disturbers of the dead appear sooner in Lycia than in any other place, whence the practice spread to the rest of Asiatic Greece. Such, at least, is the conclusion that may be deduced from the comparative study of funerary inscriptions.¹ It is, then, probable that from the earliest time the cult of the dead had a considerable importance in Lycia; and, perhaps, when we are able to read fluently Lycian texts, they will tell us the particular form the religion of the tomb, common to all the other peoples of antiquity, had assumed with this nation.

TOWNS AND THEIR DEFENCES.

Every traveller who has visited Xanthus has noticed that the principal tombs, instead of being put outside the city walls like those of Greece, stand amidst the ruins of the upper town, a practice that seems to be peculiar to Lycia. Such would be the monument of the Harpies (Fig. 268) and other funereal towers, along with huge sarcophagi figured above. The habit, though remarkable, might have been surmised by a single glance

¹ HIRSCHFELD, "Ueber die griechischen Grabschriften welche Geldstrafen anordnen," in *Koenigsberger Studien*, 1887, 8vo.

at the views of towns depicted on certain Lycian bas-reliefs; notably in one of the pictures from Pinara, where funerary monuments of different types are mixed up with edifices comprised within the ramparts (Figs. 252, 253); as well as a representation of

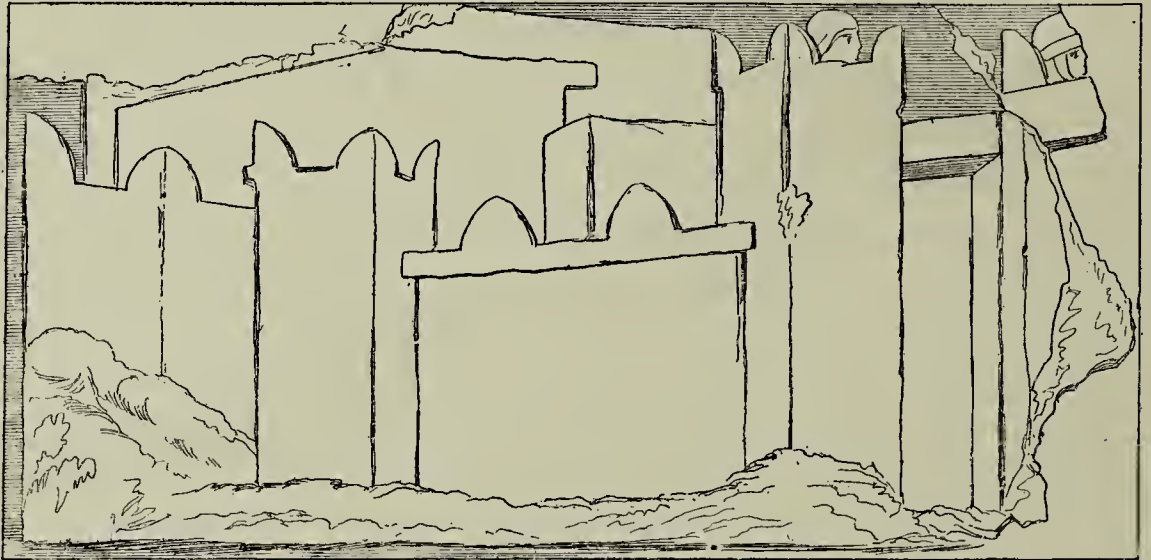

FIG. 269.—View of a Lycian city. *Monumenti dell' Istituto*, tom. x. Plate XVI.

the same nature at Xanthus (Figs. 269, 270),¹ which forms part of the sculptures displayed on the building known as the monument of the Nereids. The latter represented the military exploits

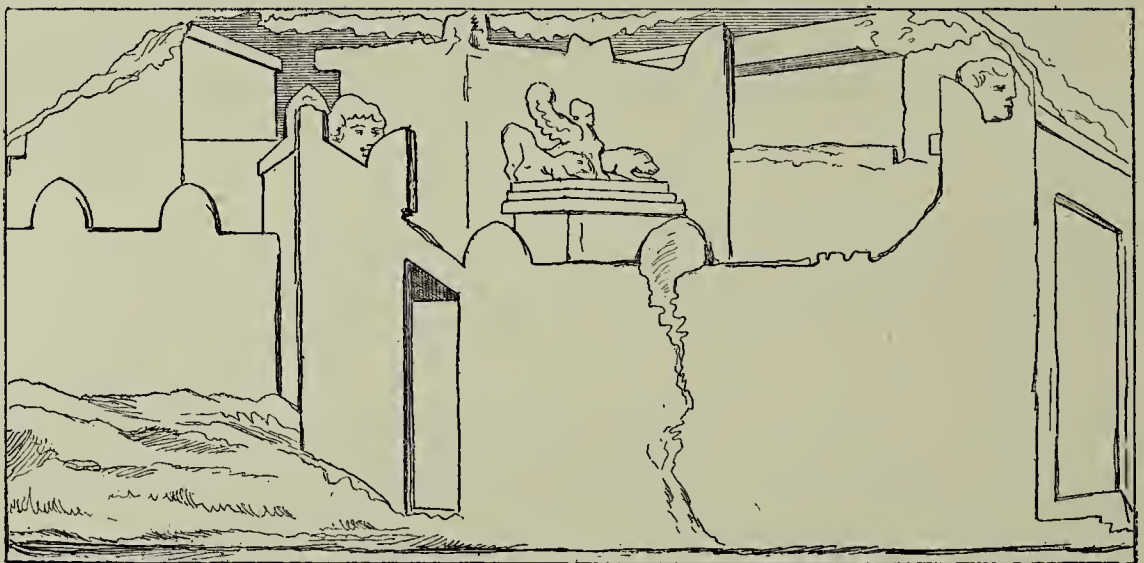

FIG. 270.—View of a Lycian tomb. *Ibid.*

of a prince or satrap of the fourth century B.C., and the places he was supposed to have besieged or taken. Over the crenelated wall of one of them appears the upper part of a monument, with a

¹ MICHAELIS, "Il monumento delle Nereidi," p. 117, in *Annali dell' Istituto di corrispondenza archeologica*, 1875.

sphinx as crowning member, in which we recognize a quadrangular stela, akin to the large Xanthus exemplar surmounted by a sphinx between two lions.¹ The latter bears a bilingual inscription in honour of a descendant of a local magnate, by name Harpagus.

What must have contributed to imbue Lycian centres with a pre-eminently singular physiognomy, were those wooden buildings we think to recognize in the sculptured views (Figs. 252, 253).

The towns were built upon heights difficult of access. But where the escarpments of the rock did not forbid an attempt at an escalade, built walls were resorted to, of which the oldest portions display polygonal masonry. The vast majority of these places, however, must have undergone so many sieges, requiring the defences to be so often repaired, as to make it doubtful whether

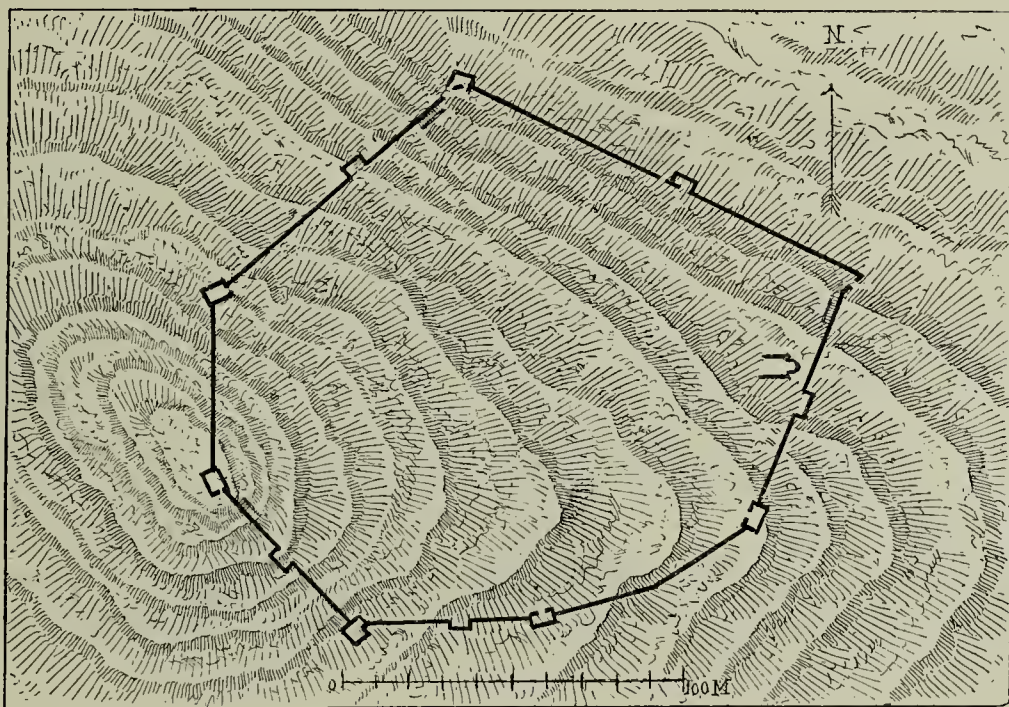

FIG. 271.—Plan of fortress, Pidnai. BENNDORF, *Reisen*, tom. i. Fig. 75.

any portion of the primitive work can be traced below the reconstructions. Xanthus affords an instance of this; so that to find a unit homogeneous in all its parts, we must fain turn to the ruins of simple fortresses, that have never been touched since the day when they were abandoned. Such would be the *enceinte* found in a remarkably good condition close to the mouth of the Xanthus river, bearing to the west. It was a fortified castle called Pidnai,

¹ Prachow has published by far the best reproduction of the monument under notice, in *Antiquissima monumenta Xanthiaca*, Plate II. Fig. 1 (fol., St. Petersburg, 1871, two pages of written text and six plates of lithographs).

which covered the territory of the Xanthians against the incursions of mountaineers inhabiting the Cragos region.¹ The wall in question stands on the summit of a low hill, and the space it embraces forms an irregular polygon (Fig. 271). It is constructed with stones of medium size, very well dressed and fixed, in almost always regular courses, without a sign of mortar (Fig. 272). The citadel had but two openings—one on the north and the other on the east side. The rampart is broken at unequal distances by

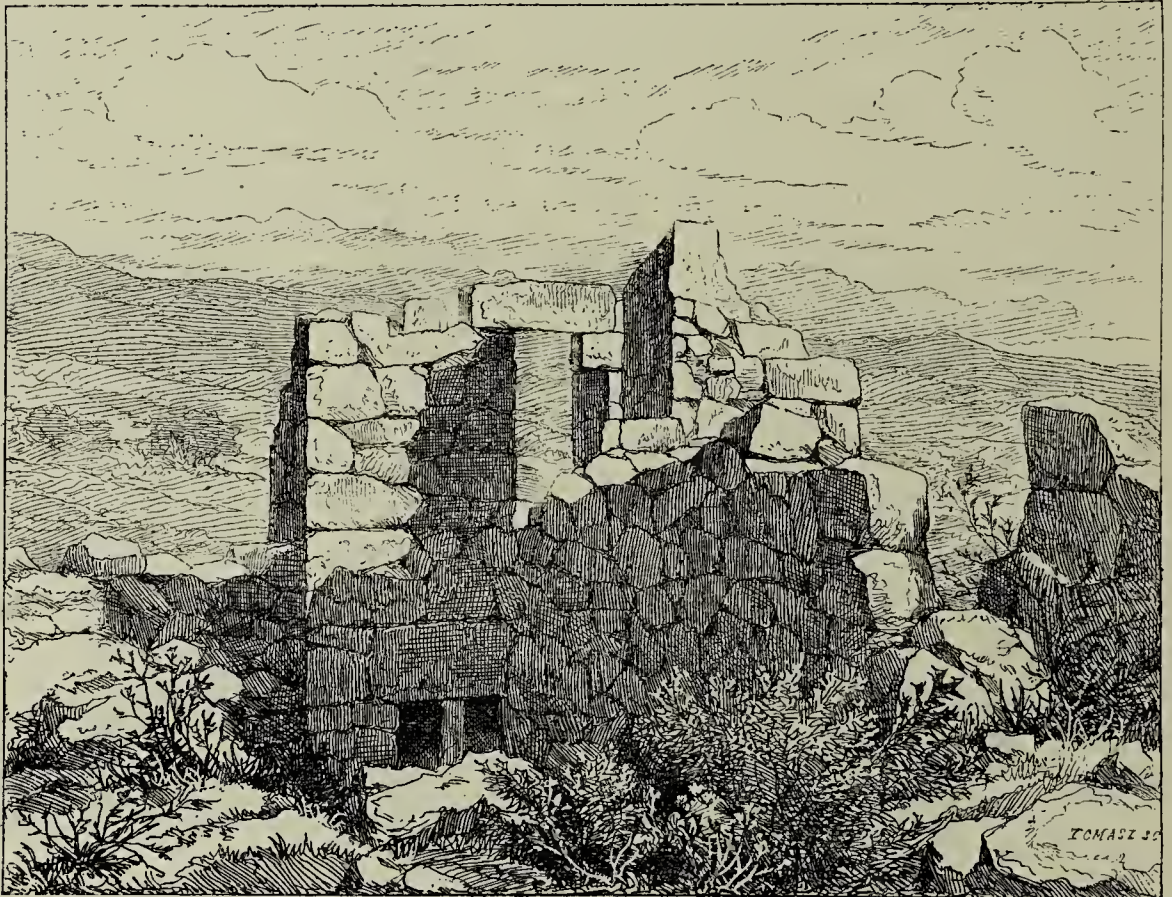

FIG. 272.—Wall of enclosure, Pidnai. BENNDORF, *Reisen*, tom. i. Fig. 71.

eleven rectangular towers, standing out boldly from the curtain, and at some points still rising to a height of ten metres. The thickness of the wall is about one metre; the top, which is covered with large slabs, ends in a crenelated edge, made up of unsquared blocks set in mortar, perhaps a later addition. The towers were pierced with loopholes, windows, and doorways, and the latter were made to open into the area. The top of the rampart was reached by very steep flights of low steps, which led from the upper or second story of the towers. On the walls are still the ledges whereon rested the joists of floor and ceiling.

¹ BENNDORF, *Reisen*, tom. i. p. 124.

Without aiming at elegance, the structure throughout evinces that the masons who constructed it were familiar with fortification works.

Very similar square towers are likewise figured in the bas-reliefs (Figs. 252, 253, 269, 270). In these, however, the wall runs along the base of the hill upon which the town was built, and both soar upwards towards the Acropolis. Lycian centres did not emerge from their plate of armour to descend and expand in the low level, until the peace brought about by Roman dominion. In the preceding age, wars between rival and neighbouring cities had been frequent; so that the Lycians were not content to surround their dwellings with a belt of ramparts to guard them against their enemies, but readily engaged in works of greater extent. Thus, about a league to the north of their town, the Xanthians barred their valley with a wall which leans against a counter-fort of Massikyτος, and runs for a distance of some four kilometres close up to the river, where it abuts on a kind of redoubt, or exercising ground crowning the hillock. The materials of which the wall is made, consist of blocks of great size irregularly cut, leaving interstices which are filled by small units. Here, doubtless, was fought the battle specified by Herodotus between Persians and Lycians, when the latter were obliged to fall back and take shelter behind the walls of their chief town.

No monuments exist in Lycia from which to obtain an idea of its temples, such as they appeared before they were rebuilt in Greek fashion, *e.g.* like the edifices whose remains are still visible at Patara and other points of the country. But for the nature of timber structures, which dooms them to prompt destruction, we might perhaps have lighted upon the outline of what has been sometimes called *hut temples*. If we except Macri and Elmalu, at the present day, throughout Lycia, mosques, at first sight, are not distinguishable from the houses of the peasantry by which they are surrounded; so that we should not grasp the purpose for which they were erected, had not the builder taken the precaution to write *Mirhab* on one of their walls.



CHAPTER III.

SCULPTURE.

THE tomb, the principal varieties of which we have passed in review, whether rock-hewn or built of well-dressed units, was decorated by reliefs as soon as the circumstances of its owner permitted him to indulge in the outlay. Thus the fine series of sculptures in the British Museum are the spoils of a few tombs in Xanthus ; whilst the liberality of half a dozen or so of *dilettanti*, coupled with the energetic action of MM. Benndorf and Niemann, have added to the wealth of the Vienna Museum, a collection of reliefs which decorated the Heroon at Ghieul Bashi.¹ We do not propose to describe or figure similar works, or those of the like nature that are still *in situ*. Originality of a high order they certainly possess, be it in the details of costume and more particularly in the themes handled by statuary ;² their execution, however, is thoroughly Greek, betraying in every line the hand of Ionian artists or their pupils ; so that they belong to Hellenic art, where we shall find them when we come to treat of the latter. For the present it suffices to show that if from the latter half of the sixth century B.C., Lycia, violently drawn out of her isolated situation by the Persian conquest and included in the satrapy of Ionia, employed Milesian and Ephesian craftsmen to decorate the tombs of her princes and chief citizens, she had not waited until that day to carve upon the façade of her sepulchres the human and animal form.

¹ BENNDORF and NIEMANN, *Das Heroon von Gjölbaschi Trysa*, Vienna, 1888.

This elaborate work brings to our notice the reliefs and details of the Heroon. The plates, thirty-four in number, are executed in line engraving, a process rendered perhaps advisable by the dilapidated state of most of the bas-reliefs.

² In regard to the peculiar nature of the themes referred to, consult PETERSEN, *Reisen*, tom. ii. pp. 193-196.

Benndorf inclines to consider the bas-reliefs (unfortunately much injured) which he discovered at Trysa, near Ghieul Bashi, as the most antique instances of the plastic art of Lycia (Figs. 273–275).¹ They decorated the external sides of a funereal square tower now fallen on the ground and lying on one of its faces, so that only three sides are visible. It is very similar, although not so lofty as the Xanthus specimen (Fig. 268). The top part of the plaques is broken away, and the figures seen on the remaining surface are below natural size. This, coupled with their very flat appearance and in-

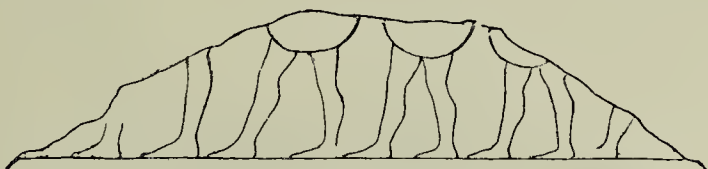

FIG. 273.—Bas-relief on tomb, Trysa. BENNDORF, *Reisen*, tom. ii. Fig. 9.

distinct outline, may likewise have been brought about by the weather. They most probably formed part of one of those funerary processions exhibited around the body of those antique vases called *dipylon*.² The least damaged slab (Fig. 273) shows the lower extremities of five men walking one after another, their faces set to the left. On the arms are carried round shields. On the next appear the busts and legs of an equal number of figures ;

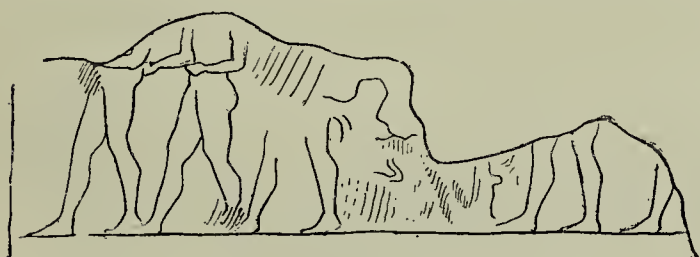

FIG. 274.—Bas-relief on tomb, Trysa. *Ibid.*



FIG. 275.—Bas-relief on tomb, Trysa. *Ibid.*

their hands stretched in front as if they held something, perhaps an object about to be offered (Fig. 274). Of the relief on the third slab nothing is left but the hind part of a horse and the heel of a rider (Fig. 275). These files recall many a figured decoration, Oriental and archaic in style ; for example, the processions seen about Cypriote sarcophagi ;³ those on the engraved bowls of Phœnicia,⁴ and the profusely ornamented ostrich eggs

¹ PETERSEN, *Reisen*, tom. ii. p. 13.

² RAYET and COLIGNON, *Hist. de la céram. grecque*, pp. 23–30, Fig. 19, Plate I.

³ *Hist. of Art*, tom. iii. Figs. 415, 416.

⁴ *Ibid.*, Figs. 548, 549.

which Etruscan tombs have disclosed ;¹ and, lastly, those instances to which reference has already been made as occurring on golden pieces of jewellery found at Corinth.² The theme is one among the most in favour with nascent plastic art, and was suggested by the spectacle of those martial pomps, composed of the associates in arms and retainers of the chief whom they mourned

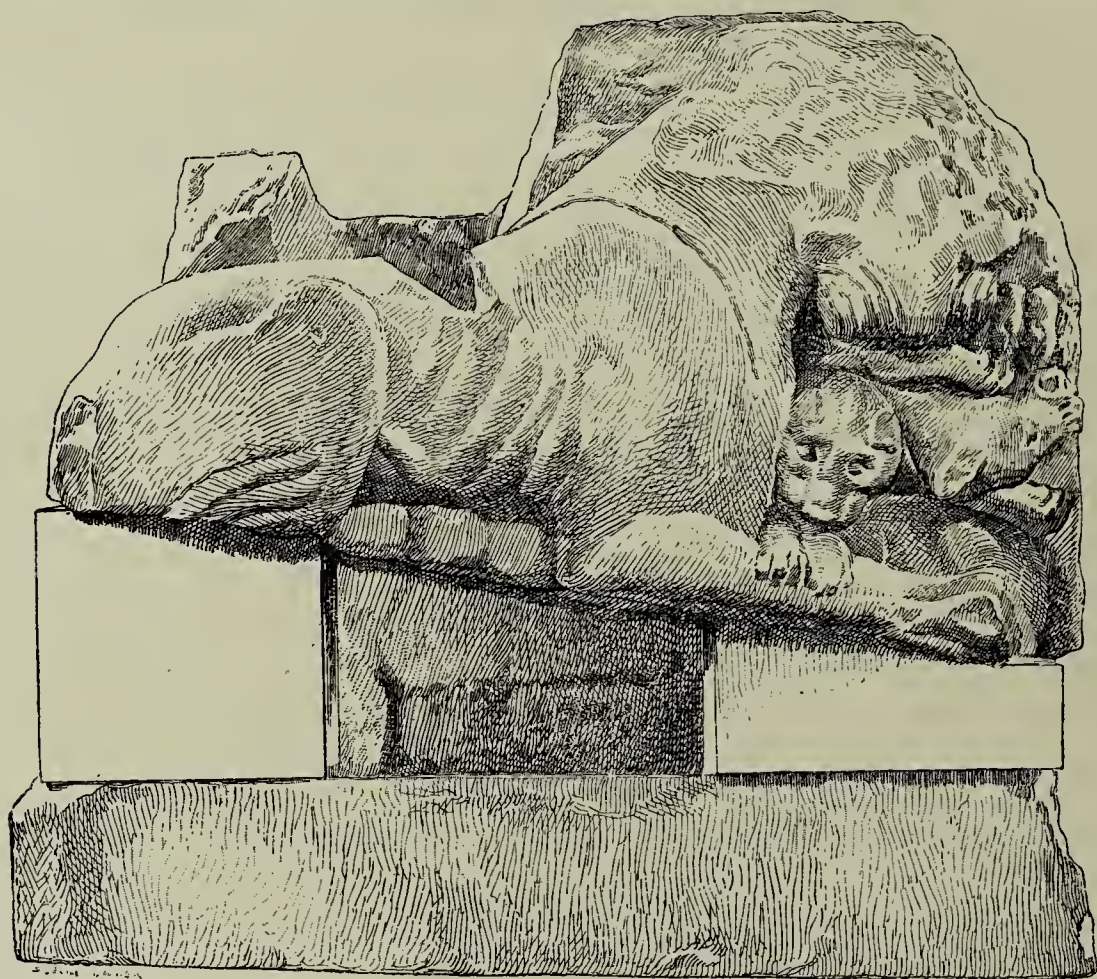

FIG. 276.—Tomb at Xanthus. British Museum. Small side. Length 1 m. 13 c. Drawn by St. Elme Gautier.

as they moved around his funereal pile, the pathetic details of which are recorded in the *Iliad*.³

To the same class of monuments belong other reliefs, properly put next to the above in the British Museum, and which would seem to rank among the oldest specimens that have come to us from Xanthus (Figs. 276–280).⁴ Unfortunately the stone or stela which served as background has been destroyed, hence no

¹ *Hist. of Art*, tom. iii. Figs. 626, 627.

² FURTHWAENGLER, "Archaischer Goldschmück" (*Archæ. Zeitung*, 1884, pp. 99–114).

³ *Iliad*, xxiii. 134.

⁴ A certain number of lions are left in Xanthus, which look fully as archaic as those in the British Museum (BENNDORF, *Reisen*, tom. i. Plate XXVIII.).

opinion can be put forth as to its original height. This does not apply to its shape, which was oblong and not square in plan; proved by the unequal length of its faces, two being long and two short. The latter are occupied each by a lion couchant. The head of the animal in Fig. 276 is much injured; but his action, which is that of a fond parent licking his cub, upon which he caressingly rests his paws, is easily read. A corner and side view of the next slab is obtained in Figs. 277, 278, representing the



FIG. 277.—Tomb, Xanthus. British Museum. View of corner.

conflict of a lion with a bull. The latter has fallen; his head, from which life has departed, is thrown so far back that the horns touch the ground, to which he is held by his victor. As to the long sides, they are partly broken. On the one are carved three figures—a horseman, seemingly nude, who moves towards the right (Fig. 279); he is followed by a man on foot, probably a slave, unarmed, and clothed in a short tunic; the warrior who comes next walks in a contrary direction from the other two. The interest which attaches to the last figure resides in the shape of his helmet, furnished with a top-piece of metal, crescent shaped, which extends from nape to forehead—a detail, it will be remem-

bered, exhibited in a bas-relief of Phrygia (Fig. 117); whilst the circular shield is not only akin to the examples seen on the earliest vase-painting of Mycænæ, but to all the monuments of widely different origin in this part of the world, including the Trysa bas-relief, to which we refer the reader (Fig. 274). It is difficult to hazard a guess at the significance of the disc carved in front of and level with the head of the warrior, which a shallow groove, sunk in the stone, separates from his helmet. Is the object hung high up against the wall a shield? Of the other long slab nothing remains

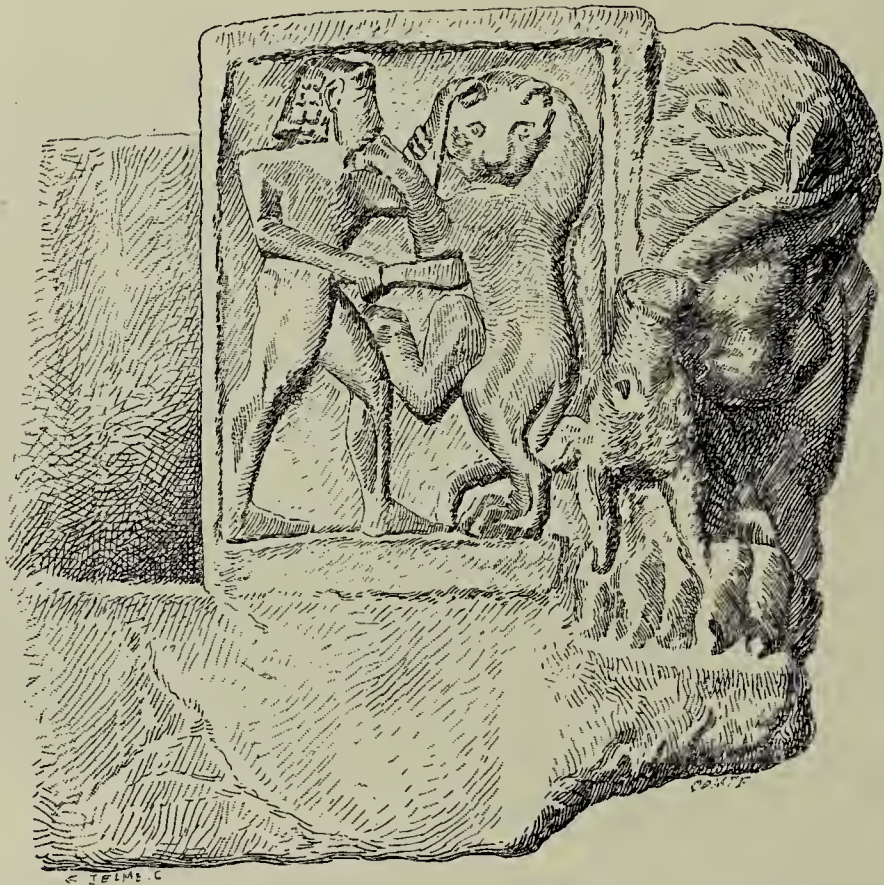

FIG. 278.—Tomb, Xanthus. British Museum. Long side. Height, 93 c.

but a group occupying about one-third of the surface, and enframed within a border in relief (Fig. 278). It probably had a pendant at the other end, whilst between the two pictures stood the doorway. This sculpture produces one of the themes dear to Oriental art, *e.g.* the struggle between a man or god and a lion.¹ The two foes stand upright, face to face; with his left hand the hero clutches the mane of the beast, whilst with his right hand he buries a huge sword in his flank, unconscious the while that the claws of the brute are tearing his shoulders and side. The pose is wholly

¹ *Hist. of Art*, tom. ii. Figs. 322, 337; tom. iii. Figs. 471, 472; tom. iv. Fig. 266.

conventional; if, in order to be more realistic, the artist had aimed at varying the traditional treatment, if he had so handled



FIG. 279.—Tomb, Xanthus. British Museum. Long side. Length, 1 m. 87 c.; height, 93 c.

the subject as to raise doubt in the mind of the spectators respecting the issue of the conflict, the symbol would have ceased

to be understood. The idea it awoke was that of a victory obtained by a powerful and beneficent being over the powers of evil. To have the notion grasped, it sufficed to posture the figures exactly as the public was accustomed to see them, without changing an iota as to aspect and position. The presence of this traditional element serves to explain the inequalities observable here and there in the workmanship. Could aught, for instance, be conceived more rigid in treatment than the group of the lion and

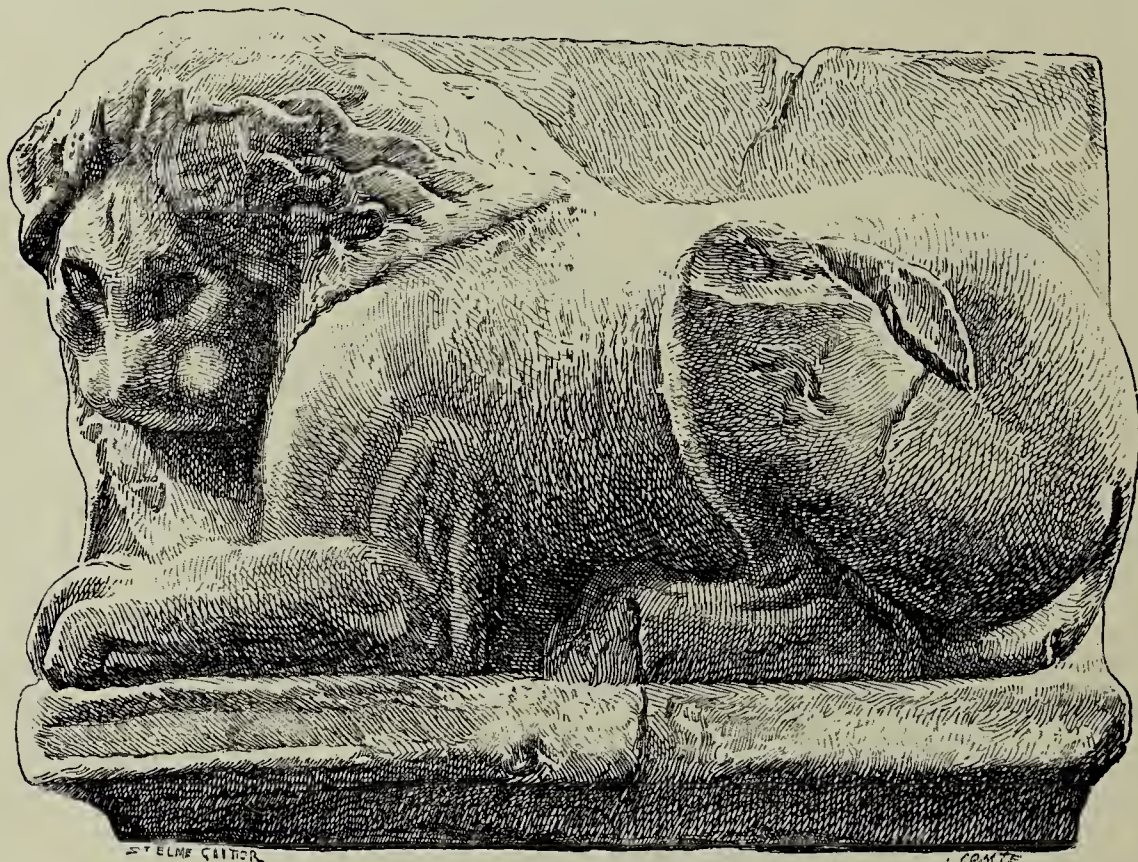

FIG. 280.—Tomb, Xanthus. British Museum. Small side. Length, 1 m. 20 c. ; height, 93 c. Drawn by St. Elme Gautier.

his victor? A bolder handling is already perceptible in the figures carved on the other long side; the horseman stands well.

But a greater step in advance was made in the pair of lions at either extremity. If there is still a certain degree of clumsiness in some of the details, if the cub and the head of the lifeless bull are not exempt from awkwardness, we nevertheless feel that we have here a really superb work, and that the attitude of the lion lying on his victim is felicitous and expressive, notably when seen sideways, as in Fig. 280. It conveys to the utmost the idea of force when at rest; the manipulation is broad, rich, subtle, and pre-eminently characteristic. We guess at the powerful muscles beneath the skin; but they do not detach themselves and project

beyond the flesh with the somewhat hard firmness which is in the habits of the Assyrian sculptor, neither do we find the dryness of execution and conventionalism which we had occasion to observe in Phrygia.¹ Here, on the contrary, nothing could be more faithful than the rendering of the rich masses of floating hair falling low over his forehead. Travellers tell us that the lion still has his lair in the Lycian Taurus; so that the artist could go to nature for his portrait.

Of the two monuments we have studied, that of Trysa may, perhaps, travel back to the seventh century B.C.; as for the other, it evinces a far more skilful chisel, and would therefore date from the sixth.² However that may be, the pair have all the appearance of being the outcome of an art as yet uninfluenced by that of Ionia, in that their themes belong to the properties of Asiatic culture. Phrygia, too, set up lions as guardians of the tomb (Figs. 64, 65); and the hero near the doorway (Fig. 280), who has just slain the king of the forest, brings to mind the group of two warriors running their spears into the Gorgon's head (Fig. 117). The situation they occupy about the entrance to one of the most important tombs of the Sangarius necropolis is akin to that of the Lycian figure. The difference is one of style. Ample and naturalistic in Lycia, it is dry and frigid in Phrygia. The inhabitants of the former country would seem to have had quite a natural talent for plastic arts—a fact that inclines one to believe that they did not give up practising them, even when they sought examples and teaching among their neighbours of the Mæander and the Hermus valleys. Consequently, in the vast array of bas-reliefs ornamenting the tombs of the Lycians, a goodly number were doubtless executed by native artists, trained at the school of Ionian masters. But whilst to a certain extent they modified their style, in other respects they remained faithful to old local traditions. Hence it is that they continued to multiply figures of lions, and went to the repertory of Oriental arts for their forms. Such would be the conflict between the lion and the bull; the group where the stag is slain by the king of the beasts; lions and sphinxes set up in pairs face to face.³ Very similar subjects were largely reproduced on

¹ *Hist. of Art*, tom. v. pp. 178, 179.

² M. Benndorf inclines to think that the sculptures in question are anterior to the Persian conquest (*Reisen*, tom. i. p. 88).

³ FELLOWS, *An Account of Discoveries in Lycia*, 1841, plates opposite pp. 174, 187, 197; TÉXIER, *Description*, tom. iii. Plate CCXXV.; PRACHOW, *Antiquissima monumenta Xanthiaca*, Plates IV.–VI.

coins (see tailpiece, end of chapter). One thing to be noted is that the Chimæra, so often met with in Cyprus, is conspicuously absent in Lycia, where we might expect it would crop up in bas-reliefs and monetary types. On the other hand, the man-headed bull of Assyria and Persia is not rare.¹

A habit that should be very ancient in Lycia, since it has never been out of fashion, is the use of colour to give point to the decoration. Vestiges of pigments have certainly been discovered about mortuary towers, acknowledged on all hands as among the archaic types of Lycian tombs. Thus the panels of one of them were tinted, whilst elsewhere we find them ornamented by carving unrelieved by colour.² Again, the ground, in more than one bas-relief of subsequent ages, was painted blue or red, and the dress yellow or violet.³ It was the same with architecture, where, over numerous rock-graven inscriptions, the brush of the painter has been drawn, and the lettering picked out in red or blue.⁴ And so it happens that in the pure light which recalls that of Attica, man took pleasure in adding here a little and there a little to the wealth and variety of brilliant harmonies that charm the eye; the light yet vivid tints he applied to sculptures and edifices, stood out from the dull white of the limestone, their point and sparkle being enhanced by the sombre green of pines, the azure of sky and sea, and the dazzling splendour of snowy peaks on distant Taurus, glorified by the rays of the sun.

¹ SIX, *Monnaies lyciennes*, Nos. 90, 93, 95, 143, 144.

² BENNDORF, *Reisen*, tom. i. p. 87.

³ FELLOWS, *An Account*, etc., plate opposite p. 199; TÉXIER, *Description*, tom. iii. pp. 208, 239, 240.

⁴ DE GOBINEAU, in his "Catalogue d'une collection d'intailles asiatiques" (*Revue archéologique*, N.S., 1874, p. 239), assigns to Lycia an intaglio picked up in Mesopotamia; in so doing he is entirely guided by the device figured upon it, in which he thinks he recognizes Pegasus and Bellerophon. But inasmuch as the inscription is in the Aramaic language, we incline to ascribe the stone to Lycia. Ménant has included among Persian intaglios a cylinder in Le Clercq's collection, which represents the offering of a dove to a seated goddess, by a personage whom he identifies with an Achæmenid prince, because of his head attire and dress (*Recherches sur la glyptique orientale*, tom. ii. Plate IX. Fig. 2, pp. 174, 175). Yet the male figure is wanting in some of the attributes that would define it with absolute certainty, such as spear and bow; whilst the pose of dove and goddess, and, indeed, the execution throughout, recall the bas-reliefs on the Tomb of the Harpies at Xanthus. One is tempted to ask, with M. Heuzey, whether we are not confronted here by a Lycian monument, in which case the male figure would naturally be a dynast of Lycia. An inscription in Lycian characters could alone confirm the conjecture, but that is sadly to seek.

The glyptic art of Lycia, like that of Phrygia, is as yet an unknown quantity. To my knowledge no cylinders, cones, or intaglios of any kind have been published with inscriptions in Lycian characters incised upon them. They alone could give us the clue by which to distinguish gems engraved for and by the Lycian people. We cannot suppose for a moment that they were without seals; these instances of their activity, however, are confounded in our collections with Oriental and Greek intaglios.

Lycian numismatics do not enter into our scheme, at least in this history, because recent investigations tend to prove that the oldest coins of Lycia, those struck in Xanthus with a hollow square and a wild boar (see tailpiece, chapter i.), are not older than the seventh century B.C.¹—a period when the administrative and commercial relations established by Persia between the subjects of her vast empire began to penetrate Lycia, whose borders, whether towards the sea or land, had hitherto been closed against alien influences. The specie she issued about this time was of Lydian weight, but as she found it; that is, much reduced from its weight standard by long circulation. Lydian coiners had certainly drawn their inspirations from the staters of the great Ionian cities, but they also created distinct and useful types of their own; contrary to Lycia, whose coins are destitute of originality as to size, workmanship, or the types figured upon them. The device of many of her coins is the “triskelis,” or so-called “triquetra,”² a name derived from three serpents’ heads which usually figure in the field, much after the fashion of those supporting the famous tripod at Delphi, consecrated by the Greeks to Apollo after the battle of Plataea. The number of heads is not constant; some coins having as many as four—“tetraskelis,” whilst others have but two—“diskelis.” The Greeks connected the symbol with the cult of Apollo, which they represented as very popular, and of hoary antiquity in Lycia.

¹ ŠIX, *Monnaies lyciennes*, p. 6.

² Literally, three-cornered, triangular, triceps. The number of heads may have been regulated by the different size of the coins in question, probably answering to different values.—TRS.



CHAPTER IV.

GENERAL CHARACTERISTICS OF LYCIAN CIVILIZATION.

IT would be natural that some surprise should have been felt at the place we have assigned to Lycia, inasmuch as the plan pursued in this history does not extend to that class of Lycian monuments which have most occupied the attention of archæologists. In so doing we were actuated by the fact that Lycia, in virtue of her origin, alphabet, language, and certain sides of her plastic art, belongs to that very old world of Anterior Asia whose development preceded, as it prepared, the unfolding of Hellenic culture. Nowhere is her primæval social state more evident, than in the curious rock-inscriptions seen on the façades of tombs built in imitation of wood structures.

Timbers are connected at right angles in the valley of the Nile. This habit of the Egyptian builder arose out of his predilection for perpendicular and horizontal lines, which led him carefully to banish from the walls and roofs of his edifices oblique pieces. The fact that the woods within reach of his hand were mediocre in the extreme, that stately beams could not be obtained, nor square pieces of any length, and far less curvilinear ones, may have had something to do with, but was not the sole reason for a choice which endows his wooden house with its look of firmness and chest-like aspect, since he carried these same elements into constructions scarcely needing them, in those light open structures, which we attempted to restore from paintings where they often figure. In both classes of buildings he had recourse to almost smooth faces and flat attics. With him square vertical beams play an all-important part; they are put close to each other over the whole surface, the only voids being those required for the piercing of doorways and windows, whilst their width is so feeble as only to allow of narrow divisions or panelling.

On the other hand, the balance between uprights and cross-

beams hangs pretty even in the carpentry work of Lycia. Here the wall-plates of the wooden frame stand out boldly at either side, whilst the roof often presents oblique and even curved pieces, which cannot be obtained except in timbers of excellent quality, handled, too, by skilful craftsmen. Again, whether the house covering is flat or a roof with double slope, instead of the small boards, slender fillets, and tenuous rods employed by the Egyptian carpenter, we invariably find large divisions such as stately oaks, many centuries old, and pines of enormous bulk alone could furnish.

Difference in the quality of the materials to hand is the chief cause why methods proceeded on different lines in the two countries. If the woodwork of Lycia is distinguished by ampler and firmer shapes than that of Egypt, this, as already stated, was because it was cut in timbers of superior quality, which enabled the artisan to resolutely divide his surfaces into great divisions, whilst the frank salience of his timbers provided more accentuated effects of light and shade over the façades. The art of the carpenter is more advanced, the types he created are nobler, because they are less minute, and the eye can more readily take in the presiding lines of the construction, the skeleton frame of the structure.

Our reason for having insisted on these peculiar monuments is that they naturally lead up to the manifestations of Greece in this domain, where we shall have much to say as to the way her architects constructed their timber frames. Unlike the Lycians, the idea never seems to have dawned upon them of compelling stone to reproduce wooden forms; and yet they were placed in surroundings that recall those of their Lycian colleagues, since they had, though less plentifully perhaps, the same kinds of woods at their disposal. Consequently, when the time comes for us to reconstruct Hellenic timber-work, we shall turn to that of Lycia for more than a useful hint; in the mean while it will aid us in re-constituting the wood-piles which upheld the esplanades of Persia.



ADDITIONS AND CORRECTIONS.

Page 7, note. To the list that Professor Ramsay has published upon the antiquities of Phrygia, should be added the memoir entitled, "A Study of Phrygian Art" (in *Hell. Studies*, vol. ix. pp. 350-380; vol. x. pp. 147-189). This essay is not yet the realization of the wish expressed by us, to the effect that Professor Ramsay should undertake a complete description of that district; for we find in it no more than remarks upon matters of detail, thrown out as they suggested themselves to the mind of the author. The first part is taken up with a disquisition upon the ethnic affinities of the Phrygians, their entrance into Asia Minor, the history of the state they founded, and the origins of their art. Professor Ramsay's ideas coincide, in the main, with those I have expressed. He then supplements the account contained in former papers with regard to several monuments, such as the Broken Tomb, the Lions' Tomb, Midas city, and he touches upon the relations between Phrygian and Mycenaean art, a question of vital interest for archæology. The second part is little more than a critical review, a kind of errata, of that portion of our history dealing with the monuments referred to above. According to Professor Ramsay, it would appear that we have not always grasped the drift of the documents he forwarded to us. Whilst acknowledging once more his liberality, we must remind him of the state of the drawings he placed at our disposal, incomplete as they were, fragmentary and often contradicting one another. Besides photographs and drawings already published, we had to choose, for the same monument, between two or three sketches made at different times by the professor himself, Mrs. Ramsay, or M. Wilson, during the various visits they paid to the monuments. To select from among these sketches, accompanied by very succinct notes, was not by any means an easy task. We think that, all things considered, we did the best that could be expected under the circumstances. Professor Ramsay points out some few mistakes. His remarks appear to us to bear, for the most part, upon details of very trifling importance; and in the impossibility of comparing the two sets of pictures, it is often difficult to make out wherein the discrepancy lies. It seems to us that, could they be placed side by side, the difference complained of would very often go undetected.

Consult also, by the same, "Syro-Cappadocian Monuments in Asia Minor" (*Mittheilungen des k. d. Archæ. Athen*, tom. xiv. pp. 170-191).

It will be quite a business for future bibliographers to collect the valuable papers which Professor Ramsay has scattered up and down in more publications than can be counted on one's fingers. Great economy of labour would have been effected had he thought fit to bring them out in book form!

Page 8, note 1. In his recent work Professor Ramsay adduces fresh and convincing data in support of his conjecture as to the Ionian origin of the Phrygian alphabet (*Journal*, vol. x. pp. 186-189).

Page 32, foot-note. Whoever may have been the author of the treatise of *Isis and Osiris*, attributed to Plutarch, there is no doubt as to his having thoroughly grasped the under-current of ideas that pervaded the religious rites referred to. "The Phrygians believe," he writes (§ 69), "that the god sleeps in winter and wakes in summer. In their orgiastic festivities they now celebrate his going to sleep (*κατευνασμοὺς*), now his awaking (*ἀνεγέρσεις*). The Paphlagonians declare that in winter he is held in fetters and a prisoner, but that he breaks his iron chains in spring and moves again."

Page 58, note 1. M. Humann has published a new edition of the pamphlet cited by us, with illustrations, in *Mittheilungen* of the Institute at Athens, 1888, p. 22, under the heading, "Die Tantalosburg im Sipylus."

Page 114 and following. As already observed, the restoration made by Professor Ramsay of the Broken Tomb agrees in every respect with our own. We submitted the results reached in consequence of his sketches, and we are happy to find that, at least in this instance, he acknowledges our having used them correctly (*Journal*, vol. ix. pp. 354-364, Figs. 1-9). His inner restoration coincides, so to speak, with every touch of M. Chipiez' inner perspective view.

Page 120. In *Journal*, vol. x. pp. 164, 165, Fig. 18, Professor Ramsay engraves another specimen, the Yapuldak tomb, of which a plan and two sections will be found p. 181, Fig. 18. Our Fig. 75 represents the façade alone.

Page 146 and following. For the description of Midas city and its remains, whether of roads, walls, buildings, altars, or cisterns, see RAMSAY, *Journal*, vol. ix. pp. 374-379, Figs. 11, 12. The plan (Fig. 11) was laid down with great accuracy. In it are carefully indicated the traces left by the wall that once surrounded the plateau; the stones have disappeared, but the place they formerly occupied is shown by the grooves cut in the rock to receive them.

Page 223. Professor Ramsay does not share our view with regard to the Broken Tomb and the Lions' (rampant) Tomb. He would place them, in time, before the Midas monument (*Journal*, vol. ix. pp. 364-377; x. pp. 152-154). We adhere to our expressed opinion, that those tombs grouped around the Midas monument, exhibiting geometrical and vegetable decorative forms, are, like the monument itself, older than the exemplars of the Ayazeen necropolis, whereon are sculptured animal and human figures, lions and warriors. In our estimation it is scarcely compatible with analogy to suppose that a decorative scheme wholly made up of linear elements, which everywhere else belongs to the beginnings of art, should have followed here a period during which the presentment of the living form was handled with a certain degree of freedom. Then, too, the shaft or well deliberately chosen, as means of approach to the vault in the majority of specimens forming the group of tombs embellished with meanders and lozenges, is a disposition of a more primitive character than the ornate doorway.

Page 242, note 1. Professor Sayce thinks that he has found a Lydian inscription. It consists of three lines engraved in small characters on a soft, dark-coloured stone, supposed to have been picked up among the ruins of Sardes. Such was the statement made to the Rev. Greville Chester, when, in 1887, he acquired the monument at Smyrna for the Ashmolean Museum at Oxford. The letters of the inscription seem to belong to the Carian alphabet, to which Professor Sayce has devoted so much attention. We leave the care of commenting and publishing the text to the accomplished philologist.

Page 244. Inscriptions have fully confirmed the assertion of Herodotus (i. 92), to the effect that most of the columns in the temple of Ephesus were

gifts from Cræsus. Fragments of the first temple of Ephesus, exhumed by the late M. Wood, after having lain forgotten a long time in the British Museum, were pieced together by M. Murray, who succeeded in restoring one column of the ancient temple. On the fragments of a torus that forms part of a base—the profile of which is most curious—nine letters were discovered by means of which the votive inscription has been reconstituted: Βα[σιλεύς] κ[ροῖσος] ἀνέ[θηκ]εν. See HICKS, *Manual of Greek Inscriptions*, No. 4, and A. S. MURRAY, "Remains of Archaic Temple of Artemis at Ephesus" (*Journal of Hellenic Studies*, vol. x. pp. 1-10).

Page 279, § 3. This was ready for the press when M. A. S. Murray, Keeper of the Greek and Roman antiquities at the British Museum, sent me photographs of the two bas-reliefs figured on this and the next page, which form part of the collection under his care (Figs. 281, 282). They came out of one of the tombs that M. Dennis explored at Bin Tepe. They are two long slabs of white marble which appear to have belonged to a frieze. The figures stand out with a slight



FIG. 281.—Lydian bas-relief. Length, 36 c. British Museum.



FIG. 282.—Lydian bas-relief. Length, 35 c. British Museum.

projection from the field, enframed by a flat border. On one of these fragments (Fig. 281) are three horsemen. The animals are of stout breed; their bridles are adorned by embroidery and top-knots. The riders sit their animals well; they are clad in a short tunic reaching nearly to the knee; a mantle seems to be rolled across the shoulder. All carry a spear in their left hand, whilst on the back of one of them is some object resembling a quiver. The heads are terribly mutilated, but helmets do not seem to have been worn. We have perhaps here a representation of the famous horsemen whom Cyrus defeated. The work shows that effort was made to introduce variety. On the other hand, the deer, to the number of three, figured on the other slab are uniform (Fig. 282). They are fairly well drawn, with their heads down, grazing in a meadow. They recall those rows of animals depicted on Greek archaic vases. These two fragments may have been part of a hunting-scene which decorated the walls of one of the funeral chambers. The sculptor's hand is already very skilful, especially in the delineation of the animals. But the repetition of the same figures, which only differ from each other in trifling details, or are precisely alike, savours of archaism. It is quite pos-

sible that the sculpture is older than the fall of the Lydian empire. Should it be called Lydian work? However that may be, it was used in the decoration of a Lydian building.

Page 287. The most elegant vases seem to have been manufactured in Lydia. The specimen found by M. George Dennis in one of the tumuli of Bin Tepe belongs to this superior style of pottery (Fig. 283). The form is not wanting in elegance, but its claim to originality resides in the style of its ornamentation, which consists of wavy black lines standing out on the red ground of the clay, evidently imitated from the *chevronné* glass products of Egypt and Phœnicia (*Hist. of Art*, tom. iii. p. 732, Plate VIII. Figs. 1-3; Plate IX. Fig. 1.) The



FIG. 283.—Lydian vase. Height, 15 c. British Museum.

painter was not content with the mere tracing of the chevrons; by varying the intensity of his black pigments, he succeeded in obtaining the effect of glass. The upper edge of the vase is adorned in the same taste. This happy adoption of devices proper to glass testifies to the dexterity of the Lydian potter.

Page 328. The affirmation contained in these lines has ceased to be true. In 1887 M. Bent visited Cape Krio, near Cnidos. "At the point," he writes, "where the promontory contracts into a narrow isthmus, we saw traces of tombs recently laid bare by tropical rains, in which we found a number of small marble figures, like those I collected at Antiparos and described in this *Journal* (vol. v. p. 50). One represents a personage seated in a chair playing on a harp, the

facsimile of that held by a figurine from Amorgos, now in the Museum at Athens; another is a female figure with a crescent on her head, resembling in every respect the Tenos exemplar. All these statuettes have a strong family likeness to those which come from the islands; in them we have another proof that the primitive inhabitants of the islands—as held by Thucydides—belonged to the Carian stock” (“Discoveries in Asia Minor,” *Hell. Studies*, vol. ix. pp. 82-87). Should other discoveries of the like nature be made in Caria, they would not only confirm the inference to be drawn from this first “find,” but forthwith solve the problem; we could then boldly assign a Carian origin to all the statuettes of the islands.

Page 390, note 4. Closer examination of the cylinder, which exhibits an offering to the dove, has led M. Ménant to withdraw the attribution of it to Persia. He now finds that the intaglio is not connected in any way with the Achæmenidæ, and that the so-called king is a woman. See *Catalogue de la collection Le Clercq*, tom. i. pp. 211, 212, and note No. 385.



INDEX.

A.

ABEL, Otto, 2 *n.*
 Adler, 277 *n.*
 Ægina, early coins of, 255-257.
 Ælian on the invention of coinage, 253 *n.*
 Agdistis, 31.
 Ainsworth, 203, *n.* 1.
 Alabaster, Oriental, in Lydian tombs, 285.
 Alinda, 317.
 Alphabet, Phrygian, 8, 9, 27, 78, 85; Asianic, 95, 213, 214, 301; Lycian, 304.
 Alyattes, tomb of, 260, 261.
 Animals facing, in Phrygia, 107, 120, 123, 125, 128, 136, 149, 151, 153, 177, 196, 200, 206; Lycia, 373; of great size in Phrygian tombs, 177, 349.
 Antiphellus, 349.
 Apamœa Kibotos, coins of, bearing arch, 6 *n.*
 Aperlæ, 349.
 Appian, 352.
 Applied ornament on slabs of sarcophagi, 325, 326.
 Arbois de Joinville, 1, *n.* 1.
 Archilochus, 249, 308.
 Armenians, their kinship with the Phrygians, 1-3, 28.
 Arrian, the *Bithynians*, 30 *n.*; *Anabasis*, 352 *n.*
 Arslan Kaia, 149.
 Artemis, great Asiatic goddess of nature, 236; Gygæa, 278.
 Athenæus, 297 *n.*
 Atys, in Phrygia, 32, 34, 35, 81; in Lydia, 238, 239, 281, 395.
 Ayala in Lycia, 335.
 Ayazeen, 102.

B.

BAGAIOS, Phrygian name of Zeus, 3 *n.*, 32.
 Barter, 250
 Barth, 105.
 Base of column in Paphlagonia, 199.
 Beard, how worn during Phrygian empire, 188.
 Beds, funereal, in Phrygia and Lydia, 272, 273.
 Belevi, tumulus of, 274, 275.
 Benndorf, Otto, researches of, in Lycia, 189.
 Bernhardt, 29 *n.*
 Beulé, 158 *n.*
 Bin Tepe, Lydian necropolis, 262.
 Bithynians, Thracian origin of, 1 *n.*
 Brick, in Lydia, 279, 280; in Caria, 319.
 Bull, on sepulchral façade, 121-128; on Lydian coins, 284; heads of, on Lydian trinket, 288; slain by lion on tomb at Xanthus, 384.

C.

CADMOS, mount of, Semitic origin of the word, 303 *n.*
 Capital, in Phrygian tombs, 137; Paphlagonia, 201, 203; with lions' heads at Iskelib, 206.
 Carpets, ornament in Phrygian tombs copied from, 184-224; manufacture in Phrygia, 188-193; in Lydia, 297.
 Chabouillet, 295.
 Charalabande, tomb at, 62, 63.
 Chase, on stone ram in Phrygia, 165; Lydian tomb, 396, 397.
 Cherbuliez, André, 37.

Chimæra does not occur in Lycia, 390.
 Choisy, exploration of, in Lydian necropolis, 268-273; work of, on builder's art, 273 *n.*
 Cibyratides, 345.
 Circular shield, in Phrygia, 169; in Lycia, 387.
 Coinage, invention of, by the Lydians, 250-257; Lydian mintage, 280-285; Lycian, 391.
 Column, in Phrygian tombs, 137, 138; in Paphlagonia, 199.
 Conze, 191 *n.*
 Cornice architraved in Phrygian tombs, 130.
 Critias upon the Carians, 308.
 Cræsus, conquests of, 245; his Greek leanings, 245-247.
 Curtius, E., 38 *n.*, 242 *n.*, 254.
 —, G., 85.
 Cybele, religion of, 31-35; colossal statue near Magnesia, 55; may be recognized at Buja, 68, 69; figures of, rock-cut in Phrygia, 144-147, 153, 154; outlined in Cappadocia, 212; in Lydia, 236; temple of, at Sardes, 279; mother of Midas, 101 *n.*

D.

DEAD, importance of cult of the, in Lycia, 377.
 Delikli Tach, tomb at, 87, 89, 91, 93, 94.
 Dennis, G., excavations of, in Lydia, 286.
 Dentels in Phrygia, 130-137.
 Diamond pattern as ornament, 327.
 Dion, 352 *n.*
 Doghanlou Deresi, 83, 142.
 Door, false, in Phrygian tombs, 86, 90, 92; to vaults, 105, 106, 110, 118, 125-127, 132, 137-139; with sloping jambs in Phrygia, 120-124, 134, 136.
 Dumont, Albert, 287 *n.*
 Duncker, 2 *n.*, 29 *n.*, 31 *n.*

E.

ELECTRUM, 25, 257, 281, 282.
 Elogos, probable etymology of, 28 *n.*
 Embroidery in Phrygia, 182, 183, 191, 192.
 Ephorus on the invention of coinage, 253.

F.

FABRICIUS, Dr., 61 *n.*
 Fibulæ, bronze, in Caria, 327.
 Figurines, stone, in the islands of the Archipelago, probable origin of, 329.
 Flute (reed) in Phrygia, 28.
 Fox on Lydian coins, 282.
 Froehner, 289 *n.*
 Frontal in Phrygia, 219-221.

G.

GAULTIER D'ARC, 65 *n.*
 Gelzer, 10 *n.*
 Genesis, ch. x. of, 236.
 Geometrical decoration, in Phrygia, 182, 191; Lydia, 286-289; Caria, 395.
 Ghieul-Bashi, heroon at, 382, 383.
 Glass, imitation of, on clay vase from Lydia, 397.
 Gordion (town), 7, 8 *n.*, 229 *n.*
 Gordios, 7, 12, 13, 24.
 Gorgon, colossal head of, on façade of Phrygian tomb, 117, 169, 173.
 Greek language, its affinities with Phrygian, 2 *n.*
 Greeks, relations of the, with the Phrygians, 10-12.
 Gregorovius, 242 *n.*
 Griffin in Phrygia, 149.
 Guigniaut, 31 *n.*
 Gyges, gifts of, to Delphic Apollo, 10; conquests of, 144, 145; date of, 234; advent of, 240, 243.

H.

HAMBAR KAIA, 197.
 Hamilton, 37, 262.
 Harpies, tomb of, 373.
 Hathor, outline on rock recalling head-dress of, 146, 147.
 Haussullier, 303.
 Hawk, heads of, on Lydian trinkets, 288.
 Hecataeus, 349 *n.*
 Hecates, 304 *n.*
 Helbig, 173 *n.*
 Helmet, on Phrygian bas-relief, 169, 308; on Lycian tomb, 387.
 Heraclidæ Pontinus, 352 *n.*
 Hercules in Lydia, 239, 240.
 Hermodike, 12, 178.
 Herodotus, 1 *n.*, 5 *n.*, 14, 193, 242-246, 248-253, 255, 258, 306, 307.
 Hesychius, 101 *n.*
 Heuzey, 297.

- Hicks in relation to Iasus, 315.
 Hirschfeld, Gustav, on Sipylus, 42 *n.* ;
 researches in Paphlagonia, 192 *n.* ;
 views on Syro-Cappadocian culture,
 208 ; funereal formulas in Lycia, 377.
 Hissarlik, 21, 22.
 Hittites, monuments on Sipylus must
 not be ascribed to, 16, 17 ; inscription
 of, in Phrygia, 79 ; their influence on
 the Phrygians of Sipylus, 216, 224.
 Hoiran, 367.
 Homer, his notion of the Phrygians, 6 ;
 of Tantalus, 12, 13, 25 ; helmet of
 his heroes, 168-171 ; the Mæonians,
 232 ; tinted ivory in Mæonia, 297,
 298 ; on the Carians and Leleges,
 298 ; the Lycians, 339 *n.* ; dead march
 of warriors, 384.
 House, rock-cut, in Phrygia, 75, 76.
 Humann, K., 37 *n.*, 58, 63 *n.*
 Hump, ox with, 129.
 Huyot, manuscripts and drawings of,
 315 *n.*
 Hyena on Carian vase, 321, 322.

I.

- IARDANOS, 238.
 Iarik Kaia, 57-62.
 Iasus, 318.
 Iliouna, and not Maouna, in Egyptian
 inscriptions, 238 *n.*
 Imitation of carpentry work on stone,
 Phrygia, 180-183, 196-207.
 Ingots, gold and silver, weighing of,
 251, 257.
 Inscriptions, Phrygian, 8, 81, 94, 95.
 Ionic order, origin of, 186, 218.
 Iskelib, 201, 202.
 Isocrates, 350.
 Istar on stone mould, 294, 295.
 Istlada, 359.
 Ivory dyed in Lydia, 298.

K.

- KASTAMOUNI, tomb, 195, 196.
 Kiepert, map of Lycia, 334.
 Kirchoff, Adalbert, 9, *n.* 4.
 Klaft on Lydian trinkets, 292.
 Kumbet, 71-76, 124-131.

L.

- LABORDE, Léon de, 124 *n.*, 315 *n.*
 Labraundeus, one of the surnames of
 Zeus in Caria, 303.

- Labrys, Lydian for axe, 303.
 Lagarde, Paul de, 3 *n.*
 Lagina, 304 *n.*
 Language, Phrygian, 5, 6 ; Lydian, 237 ;
 Carian, 303, 304 ; Lycian, 337, 338.
 Lassen, 2 *n.*, 3 *n.*
 Le Bas, *Voyage archéologique*, 280.
 Leake, Martin, 6 *n.*
 Leleges, wall of, 314-317.
 Lenormant, François, 2 *n.*, 6 *n.*, 12 *n.*,
 30, 251, 255, 256, 282, 342.
 Lion, conventional representation of, in
 Phrygia, 3 ; at entrance of tombs, 107,
 108, 110, 111, 125, 128, 174, 175,
 200 ; companion of Cybele, 153, 200 ;
 on Lydian coins, 284 ; on tombs at
 Xanthus, 384-388 ; combat of, with
 Lycian hero, 386.
 Loft pointed in Lycian tombs, 369-373.
 Luschan, Von, 344 *n.*, 355 *n.*

M.

- MA, name of great goddess in Phrygia,
 30.
 Mæonia, name found in Homer, and
 also in the Roman epoch, 230 *n.*
 Mânes, 236.
 Marsyas carved on rock, Phrygia, 167.
 Martin, André, 67 *n.*
 Maspero on the name of Iliouna, 238 *n.*
 Matriarchate in Lycia, 353.
 Maury, Alfred, 30 *n.*
 Meander, ornament called, in Phrygia,
 81-85, 98, 220.
 Men, god, 31, 236.
 Meros, 76.
 Metal, perhaps applied to sepulchral
 exteriors in Phrygia, 84.
 Meyer, Edm., 30 *n.*
 Michaelis, 378 *n.*
 Midaion, 7 *n.*
 Midas, fountains of, 7 *n.* ; probable date
 of, 12 ; name unknown to Homeric
 poems, 13 ; name of, borne by several
 princes, 13, 14 ; king of woodmen
 and husbandmen, 25 ; monument ex-
 hibiting name of, 80-85, 98-224 ;
 bronze statue on tomb of, 181.
 Milchhöfer, 166 *n.*
 Milyans, Milyes, 345, 346.
 Modillions in Phrygia, 130
 Mordtmann, 74 *n.*
 Moulds, stone, for small figures or
 trinkets, 293-295, 300.
 Müntz, Eugène, 190, 191 *n.*

Music with the Phrygians, 28-30.
Myra, 349.
Mysians, Thracian origin of, 1 *n.*; closely related with the Lydians, 235.

N.

NACOLEIA, 73, 76.
Nannakos, 6 *n.*
Neræids, monument of, 378, 379.
Newton, Sir Charles, 305 *n.*, 310, 314, 318.
Nicholas of Damascus, 240, 241, 243 *n.*
Niemann, 355, 356.
Niobe, myth of, 15; colossal figure called, 16, 20, 21, 40, 41, 55, 59.

O.

OLFERS, Von, 258-266.
Omphalos, 238.
Orgies of Phrygian religions, 30-38.
Osogos, name of Zeus, 305.
Ox, horns of, as acroteria in Lycia, 371.

P.

PALMETTE on Phrygian tombs, 128, 130, 131, 138.
Panamarkos, surname of Zeus in Caria, 305 *n.*
Panofka, 14 *n.*
Papas, Phrygian name of the supreme god, 30.
Paphlagonians, 23.
Patara, 347.
Paton, excavations of, in Caria, 288, 311, 319, 327.
Pauli, Karl, 349.
Pausanias mentions monuments on Sipylus, 15 *n.*, 41.
Pelekiti, I, 65.
Pelops, 18, 39, 40; throne, 55, 58, 59.
Perrot, Guillaume, and Delbet, *Explor. Arché.*, 7 *n.*
Phallus as terminal ornament, 49, 118, 119.
Φάλος, meaning of, 172.
Pheidon of Argos first to coin silver, 253.
Phellus, 349.
Philon, treatise of, on fortification, 318 *n.*
Pidnai, 347.
Pinara, 347, 357, 361, 362, 368.
Pindar, 32, 247 *n.*

Pishmish-Kaleh, 155-158.
Πλαστηνὴ, μήτηρ, 59 *n.*
Pliny the Elder, 306 *n.*
Plutarch, *Quæst. Græc.*, 307; treatise of *Isis and Osiris*, 396.
Pollux on the invention of coinage, 253, *n.* 8.
Polychromy, in Phrygian tombs, 183, 184; in Lycian tombs, 390.
Prachow, researches on the antiquities of Xanthus, 379.
Prokesch von Osten, 262 *n.*
Prostitution sacred in Lydia, 238, 239.
Prymnessus, 73 *n.*
Pythius, wealth of, 249.

Q.

QUADESH, goddess, on Lydian trinkets, 287.

R.

RAM, carved on slab in Phrygia, 165, 215; heads of, on trinkets, Lydian or Carian, 288.
Ramsay, Professor, researches in Phrygia, 7, 9, 24, 54, 55, 56-61, 63, 72-74, 79, 84, 85, 98, 101, 105, 106, 109, 114, 182.
Rayet and Colignon, 383 *n.*
Reinach, Salomon, 9 *n.*
Rochas d'Aiglun, 318.
Rosettes on Carian sarcophagi, 326.
Rougé, De, 337 *n.*

S.

SABAZIOS, Sabazius, 31 *n.*, 32.
Sarcophagi in Lycia, 373.
Sardes, situation of, 242-244.
Savelsberg, 341 *n.*
Sayce, Professor, on the inscriptions at Hissarlik, 97 *n.*, 242, 286, 287; on the Carian idiom, 304, 309, 384; on Lycia, 342.
Schliemann, H., 21, 342 *n.*
Schmidt, J., 242 *n.*
Schmidt, Moritz, 341 *n.*
Semitic influence in Lydia, 224, 238, 239.
Semper, 259 *n.*
Serpent, heads of, in crowning member of frontal, 152.
Sidyma, 360.
Sinope, 193.

- Sipylus, history of, 14-21; description, 37-48.
 Six, researches on numismatics, 348, 351, 390, 391*n*.
 Smith, C., 286 *n*.
 Soldering of Lydian trinkets, 288.
 Solymi, 345.
 Soutzo, M. C., 256 *n*.
 Sphinx, winged, in Phrygia, 149, 152, 215, 216.
 Spiegelthal, on rock sculpture, 262; excavations of the tomb of Alyattes, 262-268.
 Stamped ornaments on slabs of sarcophagi, 325, 326.
 Stark, K. B., 15, 242 *n*.; 285, 286 *n*.
 Stewart, J. R., 7 *n*.
 Strabo, on Phrygia, 7, 18; Paphlagonia, 193 *n*.; on invention of coinage, 253; Lydia, 279; Caria, 305, 307 *n*.; Lycians, 345 *n*., 350 *n*.
- T.
- TACITUS, 20; on the Carians, 304.
 Tantalus, 62.
 Tantalus, traditions relating to, 15, 16; he is called Phrygian, 18; he works mines, 19; belongs to an older epoch than Midas, 20; lake and tomb, 39, 62, 63.
 Tchlatchef, 250 *n*.
 Telmessus (Macri), 348.
 Termilæ, Tramelæ, name of Lycians, 338.
 Téxier, Ch., 7 *n*.; on Sipylus, 37, 227; Lydia, 242 *n*.; Caria, 310, 315.
 Theopompus, 348 *n*.
 Thiersch, on small stone figures of Archipelago, 328 *n*.
 Thracians, their relations with the Phrygians, 1-8.
 Thucydides, 306 *n*.
 Tlos, 347.
 Tooth-device in Phrygia, 132, 133.
 Tralles, pottery of, 319-326.
 Trémaux, 242 *n*.
 Treuber, 332.
- Trinkets, Lydian or Carian, 287-292.
 Troglodytes, towns of, in Asia Minor, 73, 74.
 Trysa, 383, 384.
 Tumulus, funereal, in Phrygia, 46-50; in Lydia, 222, 223; Caria, 310-312.
- V.
- VAULT in tomb of Alyattes, 265.
 Vegetable, decoration derived from, in Phrygia, 187, 188.
 Vine in Phrygia, 26.
 Vitruvius, timber buildings, 71 *n*.; Lydian bricks, 280.
- W.
- WARRIOR, in Phrygia, 169-171; Caria, 308.
 Weber explores Sipylus, 40-67.
 Wells, or shafts, means of approach to vaults, 90, 105, 106.
 Winter, 313-319, 325.
 Wood, structures of, in Phrygia, 71, 180-183; Paphlagonia, 196; Lycia, 356, 357, 363-365.
- X.
- XANTHUS, city of, 351, 352, 375
 Xanthus, valley of, 345 *n*., 349.
 Xenophanes, 297.
 Xenophon upon Paphlagonia, 192 *n*.
- Y.
- YAPULDAK, 132.
- Z.
- ZENOPOSEIDON, 305.

PERROT AND CHIPIEZ'S WORKS ON ANCIENT ART.

A HISTORY OF ART IN ANCIENT EGYPT.

By GEORGES PERROT AND CHARLES CHIPIEZ.

With over 600 Illustrations. 2 vols., Imperial 8vo, 42s.

From the PALL MALL GAZETTE.

“The study of Egyptology is one which grows from day to day, and which has now reached such proportions as to demand arrangement and selection almost more than increased collection of material. The well-known volumes of MM. Perrot and Chipiez supply this requirement to an extent which had never hitherto been attempted, and which, before the latest researches of Mariette and Maspero, would have been impossible. The translator adds, in an appendix, a description of that startling discovery which occurred just after the French original of these volumes left the press — namely, the finding of thirty-eight Royal mummies, with their sepulchral furniture, in a subterranean chamber at Thebes. This event, which was one of the most romantic in the annals of archæology, is still fresh in our memories, but it forms an exceedingly interesting commentary on M. Perrot's praise of inductive processes in the practice of antiquarian research. It forms a brilliant ending to a work of great value and beauty.”

A HISTORY OF ART IN CHALDÆA AND ASSYRIA.

By GEORGES PERROT AND CHARLES CHIPIEZ.

With 452 Illustrations. 2 vols., Imperial 8vo, 42s.

From the TIMES.

“It is profusely illustrated, not merely with representations of the actual remains preserved in the British Museum, the Louvre, and elsewhere, but also with ingenious conjectural representations of the principal buildings from which those remains have been taken. To Englishmen familiar with the magnificent collection of Assyrian antiquities preserved in the British Museum the volume should be especially welcome.”

From the GRAPHIC.

“The work is a valuable addition to archæological literature, and the thanks of the whole civilised world are due to the authors who have so carefully compiled the history of the arts of the two peoples, often forgotten, but who were in reality the founders of Western civilisation.”

A HISTORY OF ANCIENT ART IN PHŒNICIA AND ITS DEPENDENCIES.

By GEORGES PERROT AND CHARLES CHIPIEZ.

*Containing 644 Illustrations in the Text, and 10 Steel and Coloured Plates.
2 vols., Imperial 8vo, 42s.*

From the MORNING POST.

“It would be difficult to find any branch of literature more attractive than that in which MM. Perrot and Chipiez have laboured with so much success. Orientalism in its widest sense has attracted many to the tombs and temples of Egypt or the palaces of Assyria and Chaldæa, and to the mind worn out with the hurry, the artificial amusements, and the commonplace of Western life, it is refreshing to investigate the relics of bygone civilisations, into whose sphere that type of progress, the steam engine, did not enter. And the particular field of Oriental archæology in which the authors have worked is surely the most attractive of all. In the art of Chaldæa and Assyria, Egypt and Phœnicia, they have not only found delightful employment and much hard work for themselves, but have been able to impart to many others the results of their studies of the sculpture and architecture, the decorative and ceramic arts of the great nations of a world that would be prehistoric but for the history built up in recent years from the remnants that remain of their handiwork.”

PERROT AND CHIPIEZ'S WORKS—*continued.*

A HISTORY OF ANCIENT ART IN SARDINIA,
JUDÆA, SYRIA, AND ASIA MINOR.

BY GEORGES PERROT AND CHARLES CHIPIEZ.

With 395 Illustrations. 2 vols., Imperial 8vo, 36s.

From the DAILY NEWS.

“ This volume will be found rich in exposition and suggestion to the student, especially the thoughtful and instructed student, of the arts of design in their early religious, symbolic, and historic aspects. The attentive care bestowed on their examinations of monuments and remains of tombs, temples, sacrificial stones, gems, jewels, bas-reliefs, and coins, and the abundant knowledge brought to bear on their researches by the archæologist and the architect, could hardly be surpassed by any examples of the proverbial German ‘ thoroughness ’ in such investigations ; and the illustrations are in themselves a perfect treasury of knowledge gathered on the spot, and guaranteed by the authority of eye-witnesses. These drawings are most admirably executed and most effectively engraved.”

From the GRAPHIC.

“ It is almost impossible within the limits of a short notice to do anything like justice to these two remarkable volumes, which possess all the learning and clearness of exposition characteristic of French scholarship. M. Georges Perrot is too well known all over Europe as an archæologist, and M. Charles Chipiez as an architect, for any joint work of theirs not to meet with instant recognition, and so clearly and pleasantly have they handled their subject that these volumes may be read with advantage by any one who takes an intelligent interest in antiquity. . . . The work is a monument of learning and patience, and its value is greatly increased by the excellence of its illustrations. It is a book to be studied by all who are interested in the arts and history of the ancient world.”

A HISTORY OF ANCIENT ART IN PERSIA.

BY GEORGES PERROT AND CHARLES CHIPIEZ.

With 266 Illustrations. Imperial 8vo.

A HISTORY OF ANCIENT ART IN PHRYGIA,
LYDIA, CARIA, AND LYCIA.

BY GEORGES PERROT AND CHARLES CHIPIEZ.

With 280 Illustrations. Imperial 8vo.

LIFE IN ANCIENT EGYPT AND ASSYRIA.

BY G. MASPERO.

With 188 Illustrations.

CHAPMAN AND HALL, LIMITED, LONDON.

DS155 .P46
History of art in Phrygia, Lydia, Caria,

Princeton Theological Seminary-Speer Library



1 1012 00023 0948

